



**Municipal
Design & Quality
Standards**

TABLE OF CONTENTS

PART 1: Municipal Design Standards

1.0 General Requirements for Subdivision Developments 1-1

1.1 Introduction1-1

1.2 General Requirements1-1

1.3 Functional Design Report.....1-1

1.4 Engagement of Consulting Engineer1-2

1.5 Fees and Deposits1-2

1.5.1 Application Fees1-2

1.5.2 Administration Fees1-2

1.5.3 Other Fees.....1-3

1.5.4 Letter of Credit1-3

1.6 Tree Preservation1-4

2.0 Subdivision Submission Requirements 2-1

2.1 General2-1

2.2 Letter of Transmittal2-1

2.3 Design Brief Requirements2-1

2.4 Drawing Requirements.....2-1

2.4.1 General.....2-1

2.4.2 Title Sheet.....2-2

2.4.3 General Plan of Services2-2

2.4.4 General Lot Grading Plan2-2

2.4.5 Sanitary Drainage Area Plan.....2-3

2.4.6 Storm Drainage Area Plan2-3

2.4.7 Plan and Profiles of Road2-3

2.4.8 Construction Details.....2-4

2.4.9 Street Lighting Plan.....2-4

2.4.10 Streetscape/Traffic Plan.....2-4

2.4.11 Draft Plan of Subdivision.....2-5

2.5 Preparation of Development Agreement2-5

2.6 Commencement of Construction2-5

2.6.1 Pre-construction Meeting2-5

2.7 "As-Built" Information Requirements2-6

2.7.1 General.....2-6

2.7.2 "As-Built" Location Plans.....2-6

2.7.3 "As-Built" Drawings of Subdivision2-6

2.8 Lot Grading Certification2-7

3.0 Roadways 3-1

3.1 Road Design3-1

3.1.1 General.....3-1

3.1.2 Geometric Design Standards3-1

3.1.3 Drainage Design Standard.....3-2

3.1.4 Road Pavement Design3-2

3.1.5 Binder Course Asphalt-Temporary Ramping.....3-3

3.1.6 Road Allowance Cross-Section.....3-3

3.1.7 Road Sub-Drains3-3

3.2 Curb.....3-3

3.3 Sidewalks3-3

3.4	Boulevards.....	3-4
3.5	Driveway Entrances	3-4
3.6	Daylighting.....	3-5
3.7	Footpaths and Walkways.....	3-5
3.8	Street Name and Traffic Sign Requirements.....	3-5
3.9	Trees	3-5
3.10	Utility Installations	3-6
3.11	Street Lighting.....	3-6
3.11.1	General.....	3-6
3.11.2	Criteria for Local Residential Streets.....	3-7
3.11.3	Criteria for Collector, Residential.....	3-7
3.11.4	Criteria for Arterial, Residential	3-7
3.12	Electrical Distribution	3-7
3.13	Traffic Signals	3-7
3.14	Emergency/Fire Access Requirements	3-8
3.15	Traffic Calming Measures	3-8
3.16	Pavement Markings	3-8
4.0	Sanitary Drainage Systems	4-1
4.1	Design Flows	4-1
4.2	Sewer Design	4-1
4.2.1	Hydraulic Calculations	4-1
4.2.2	Roughness Coefficients	4-2
4.2.3	Velocity and Slope	4-2
4.2.4	Minimum Size	4-2
4.2.5	Minimum Depth and Clearance.....	4-2
4.2.6	Location.....	4-2
4.2.7	Manholes.....	4-2
4.3	Easements.....	4-3
4.4	Pipe Design	4-4
4.5	Pipe Materials	4-4
4.5.1	Sanitary Sewer	4-4
4.6	Sanitary Sewer Service Connection.....	4-4
4.6.1	General.....	4-4
4.6.2	Pipe Size	4-5
4.6.3	Depth.....	4-5
4.6.4	Velocity and Grade	4-5
4.6.5	Sanitary Sewer Connections to Multiple Family Blocks	4-5
4.6.6	Sanitary Sewer Connections to Commercial and Industrial Blocks.....	4-5
4.6.7	Materials for Sanitary Sewers Service Connections	4-6
4.6.8	Location of Service Connections.....	4-6
4.7	Construction.....	4-6
4.8	Sanitary Forcemains and Siphons	4-6
5.0	Storm Drainage Systems	5-1
5.1	Stormwater Management.....	5-1
5.2	Rational Method.....	5-1
5.2.1	General.....	5-1
5.2.2	Watershed and Drainage Areas.....	5-1
5.2.3	Rainfall Intensity	5-2
5.2.4	Runoff Coefficients.....	5-2
5.3	Sewer Design	5-3
5.3.1	Hydraulic Calculations	5-3

5.3.2	Roughness Coefficient.....	5-3
5.3.3	Velocity	5-3
5.3.4	Minimum Sizes of Pipes.....	5-3
5.3.5	Minimum Depth and Clearance.....	5-3
5.3.6	Location	5-3
5.3.7	Manholes	5-4
5.3.8	Catchbasins	5-5
5.4	Easements.....	5-5
5.5	Pipe Design	5-6
5.6	Pipe Materials	5-6
5.7	Storm Sewer Service Connections.....	5-6
5.7.1	General.....	5-6
5.7.2	Pipe Size	5-6
5.7.3	Depth	5-7
5.7.4	Storm Drainage & Sewer Connections to Multiple Family, Commercial and Other Blocks....	5-7
5.7.5	Velocity and Grade	5-7
5.7.6	Location of Service Connections.....	5-7
5.7.7	Materials for Storm Sewer Service Connections	5-7
5.8	Construction.....	5-7
5.9	Roof Leaders	5-8
5.10	Watercourse Alterations and Outfalls.....	5-8
5.11	Erosion and Siltation Control.....	5-8
5.12	Foundation Drains.....	5-8
5.13	Stormwater Facilities.....	5-9
6.0	Water Distribution Systems.....	6-1
6.1	Design Flows	6-1
6.2	System Pressures & Structural Requirements	6-1
6.3	Friction Factors	6-1
6.4	Watermain Sizing and Layout	6-2
6.4.1	Sizes.....	6-2
6.4.2	Depth of Cover.....	6-2
6.4.3	Vertical Separation Between Watermains and Sewers	6-2
6.4.4	Horizontal Separation Between Watermains and Sewers	6-3
6.4.5	Separation of Watermain and Sewers - Special Conditions	6-3
6.4.6	Utility Crossings	6-3
6.4.7	Dead Ends.....	6-3
6.5	Line Valves	6-3
6.5.1	Type.....	6-3
6.5.2	Sizes.....	6-3
6.5.3	Number, Location and Spacing.....	6-3
6.5.4	Air Release Valves.....	6-4
6.5.5	Drain Valves	6-4
6.5.6	Valve Boxes and Chambers.....	6-4
6.5.7	Tapping Sleeve and Valve	6-4
6.6	Hydrants	6-4
6.7	Thrust Restraint	6-5
6.8	Watermain Pipe Materials.....	6-6
6.9	Tracer Wire	6-6
6.10	Corrosion Protection	6-6
6.11	Cathodic Protection of Watermain and Appurtenances	6-7
6.12	Water Service Connection	6-7
6.12.1	General.....	6-7

6.12.2	Pipe Sizes.....	6-7
6.12.3	Location.....	6-7
6.12.4	Depth.....	6-8
6.12.5	Mainstops.....	6-8
6.12.6	Curb Stops and Boxes.....	6-8
6.12.7	Materials.....	6-8
6.12.8	Meter Pit/Chamber.....	6-8
6.12.9	Re-use of Water Service Line.....	6-8
6.13	Construction.....	6-8
6.14	Water Meters.....	6-9
6.15	Water Booster Stations.....	6-9
6.16	Fire Lines.....	6-9
6.17	Greenhouse Services.....	6-10
6.18	Sampling Station.....	6-10
6.19	Removal and Abandoning Watermains and Services.....	6-11
7.0	Lot Grading and Service Drainage.....	7-1
7.1	General.....	7-1
7.2	Objectives.....	7-1
7.3	Design Criteria.....	7-1
7.4	Pre-grading.....	7-2
7.5	Sodding and Tree Planting.....	7-2
7.6	Retaining Walls.....	7-3
7.7	Soakaway Pits/Infiltration Trenches.....	7-4
7.8	Mechanical Pump Systems.....	7-4

PART 2: Municipal Design Standards - Forms

PART 3: Municipal Design Standards - Drawings

PART 4: Municipal Quality Standards¹

PART 5: Municipal Quality Standards - Forms¹

APPENDIX A: Document Revision Table

¹ Part 4, 5, 6 & 7 are not included in the public release version of this manual

PART 1:

Municipal Design Standards

1.0 General Requirements for Subdivision Developments

1.1 Introduction

The following sections outline the Town of Lincoln's requirements for all design submissions forwarded to the Town related to approval of industrial, commercial and residential subdivision construction.

The Town of Lincoln reserves the right to alter any of these requirements within the text of each Development Agreement.

Sections 1 and 2 of this document provide an outline of the requirements related to processing a development proposal and obtaining a development agreement.

Sections 3 through 7 are largely technical in nature with a primary purpose to provide guidance/set standards for the design of municipal infrastructure.

This document is not intended to be a "stand alone" manual and in situations that go beyond its scope, reference to appropriate guidelines, specifications and standards have been made.

Prior to commencement of detailed design, it is advisable that the developer and/or his consultant meet with Town Public Works staff to clarify the Town's requirements for engineering submissions.

1.2 General Requirements

All developments shall generally include the following:

- a) Roads, including hot mix asphalt pavement;
- b) Curbs and gutters;
- c) Walkways and sidewalks;
- d) Storm and sanitary sewers and services;
- e) Street name and regulatory signs;
- f) Watermains, hydrants and water services;
- g) Underground utilities (hydro, telephone, gas, cable TV, etc.);
- h) Street lighting;
- i) Tree planting;
- j) Sodding of boulevards and all residential lots;
- k) Grading to ensure adequate surface drainage;
- l) Landscaping;
- m) Fencing.

1.3 Functional Design Report

The need for a Functional Design Report will be established by the Director of Public Works or designate, during the preliminary review of the development application. The Functional Design Report shall include, but not necessarily be limited to, a global analysis of the following:

- a) Roadway Network
 - i) Impact of the development on any roads within or abutting the development;
 - ii) Preparation of Traffic Impact Study.

- b) Sanitary Sewer System
 - i) Drainage areas and proposed flows;
 - ii) Main sizing, location and outlets;
 - iii) Capacity analysis of the collection system.

- c) Storm Sewers and Storm Water Management
 - i) Drainage areas and proposed flows;
 - ii) Designation of major and minor drainage systems - direction of flow and outlet;
 - iii) Storm water management facilities,
 - iv) Main sizing, location and outlets.

- d) Water System
 - i) Main sizing, location and looping;
 - ii) Pressure boundaries, booster station requirements and treatment facilities.

1.4 Engagement of Consulting Engineer

The Development Applicant shall retain a Consulting Engineering firm licensed in the Province of Ontario, experienced in the design and execution of land development projects and is acceptable to the Town of Lincoln.

The Consultant must provide proof of professional liability insurance to the satisfaction of the Director of Public Works or designate, in the amount of \$5,000,000.00 minimum.

The Consultant retained by the applicant will prepare and/or execute the following activities in conjunction with the requirements of the Town of Lincoln's Public Works Department:

- a) Functional design report (if required);
- b) Pre-engineering survey;
- c) Soils investigation;
- d) Design brief (see Section 2 for requirements);
- e) Plans, specifications, cost estimates, tender documents and contracts;
- f) Ministry applications;
- g) Calling of tenders and analysis of bids and recommendations;
- h) General administration and resident supervision of construction;
- i) As-constructed drawings;
- j) Co-ordination of all utilities (gas, telephone, hydro, cable TV, etc.);
- k) Respond to general complaints from public.

1.5 Fees and Deposits

1.5.1 Application Fees

The Developer shall pay to the Town of Lincoln a fee as established by Council from time to time for the preparation of the development agreement. Any amendments to the original agreement will be made on a cost plus basis.

1.5.2 Administration Fees

The Developer shall pay, prior to execution of the development agreement with the Town, an amount of money equal to a percentage of the estimated construction costs of all storm sewers, culverts, sanitary

sewers, watermains, roads, curbs and sidewalks and all other construction work pertinent to the development under the jurisdiction of the Town of Lincoln. This fee shall be full compensation to the Town of Lincoln for processing of the development plan, including:

- a) Consultation and advisory services;
- b) Appraisals;
- c) Rate structure studies;
- d) Checking and approval of preliminary and detailed engineering designs and drawings;
- e) Contract specifications;
- f) Compliance and assumption inspection;
- g) Administering the development agreement from execution to final acceptance. Any front ending fees will be included as a separate item, if required.

The amount of payment shall be determined by the following scale of fees:

- a) 5% of the total cost of services up to \$100,000; plus
- b) 4% of the total cost of services in excess of 100,000 up to \$500,000; plus
- c) 3% of the total cost of services in excess of \$500,000; and
- d) Shall be payable in cash or certified cheque to the Corporation of the Town of Lincoln.

The Developer shall also be responsible for monthly payment of all Town legal costs/fees, related to administration of the development agreement.

1.5.3 Other Fees

The Developer will be required to pay a fee for water meters that will be adjusted by Council from time to time, as well as any fees established by Council relating to preparation of global planning studies.

1.5.4 Letter of Credit

Pursuant to the execution of a development agreement the minimum securities required by the Town will be a "letter of credit" to the Town's satisfaction or an equivalent cash deposit. The amount required will be calculated as a sum of the following:

- a) 115% of the estimated construction value of all municipal secondary services;
- b) 25% of the estimated construction value of all municipal primary services;
- c) 100% of the estimated construction value of the street lighting system;
- d) \$1,000.00 per unit;
- e) \$5,000.00 for legal fees.

Any of the above securities may also be held and/or used to pay outstanding Town legal fees.

For the purposes of security calculations, secondary services shall include, but not necessarily limited to the following:

- a) Sidewalks;
- b) Lot grading;
- c) Landscaping;
- d) Top asphalt.

For the purposes of security calculations primary services shall include, but not necessarily limited to the following:

- a) All underground sewers;
- b) Watermains and appurtenances;
- c) Site grading;
- d) Retaining walls;
- e) Bridges and/or culverts;
- f) Culverts;
- g) Road base;
- h) Base asphalt;
- i) Curb and gutter.

1.6 Tree Preservation

In general, trees should not be removed from development lands without prior written approval from the Town.

Where a draft plan requirement for an arborist's report has been made, efforts should be made to integrate existing significant trees into the design of the subdivision.

2.0 Subdivision Submission Requirements

2.1 General

Prior to the preparation and execution of a development agreement, (which includes a subdivision agreement, or any other development agreement), the Town of Lincoln requires that a complete technical submission be provided by the developer's consultant to the Town's Public Works Department for their review and comment.

A complete submission constitutes the following items:

- a) Letter of transmittal;
- b) Engineering design brief (3 copies);
- c) Engineering drawings in hard copy (3 copies) and electronic file format;
- d) Contract documents (3 copies);
- e) Construction cost estimate and proposed construction schedule (3 copies).

2.2 Letter of Transmittal

The letter can be a standardized form or a formal letter indicating the submission date, contents of the submission package, and the name of the appropriate contact personnel.

2.3 Design Brief Requirements

The Design Brief is a technical report summarizing the intent of the project and outlines the detail design, assumptions, calculations, supporting documentation and references to previous studies, for each component of the development. The supporting information should include, but not be limited to the following:

- a) Geotechnical report;
- b) Calculations for pipe strength and bedding requirements;
- c) Sanitary sewer design calculations including standard Town form;
- d) Storm sewer design calculations including standard Town form;
- e) Watermain design calculations/analysis;
- f) Pavement/roadway design calculations;
- g) Stormwater management calculation/analysis;
- h) Noise study;
- i) Traffic impact study.

2.4 Drawing Requirements

2.4.1 General

- a) All drawings shall be completed using AutoCAD Release 2000 or later.
- b) All drawings will be completed using metric system only. Imperial units will not be accepted.
- c) Drawing size shall be A1 (600 mm X 900 mm).
- d) All drawings shall be neat, legible and completed in ink.
- e) All drawings must contain a key plan, north arrow, current revision status, and be stamped by an appropriately qualified practitioner.

- f) All sewers, watermains, manholes, manhole numbers, pipe diameter, direction of flow pipe class and bedding, and service connections shall be shown on any drawings, as required.
- g) Where plans require more than one drawing, match lines shall be provided with no overlapping of information.
- h) A complete set of drawings shall include:
 - i) Title sheet
 - ii) General plan of services
 - iii) General lot grading plan
 - iv) Sanitary drainage area plan
 - v) Storm drainage area plan
 - vi) Plan and profile drawings
 - vii) Construction details
 - viii) Street lighting plan
 - ix) Streetscape and Traffic Plan
 - x) Draft plan of subdivision

2.4.2 Title Sheet

The title sheet shall include the following:

- a) Name of the development;
- b) Name of the developer;
- c) Town of Lincoln;
- d) Name of the consulting firm;
- e) Key plan at a scale of 1:10,000 indicating the location of the proposed development and the proposed new street alignment;
- f) Index to each drawing constituting the complete set indicating drawing number and title.

2.4.3 General Plan of Services

The general plan of services shall be to a scale of 1:500, showing the following:

- a) Roads, lots and their numbers;
- b) Sanitary and storm sewers including pipe diameter, material and direction of flow;
- c) Watermains and appurtenances;
- d) Sanitary, storm and water services;
- e) Manholes and catchbasins;
- f) Culverts and easements;
- g) Existing streets and services surrounding the development and their relation to the proposed work;
- h) Location and description of the benchmark.

2.4.4 General Lot Grading Plan

The general lot grading plan shall be to a scale of 1:500 showing the following:

- a) Existing and proposed elevations at all lot corners and 3 metres into adjoining property;
- b) Existing contouring at 500mm elevation intervals for the area under consideration, including sufficient area of the adjacent lands to establish the overall drainage pattern;
- c) Proposed road elevations at 20m intervals, at changes in grade, and at all intersections, and the location of catchbasins;
- d) Minimum basement floor elevations of proposed structures;

- e) Proposed ground elevation at the front of all houses;
- f) Proposed ground elevation at the rear of all rear walkouts, rear back split and front split lots, or where steep grades from the front to the rear of the lot are encountered;
- g) Proposed drainage easement and rear yard swales and invert elevations of rear yard swales;
- h) Direction of surface drainage on individual lots;
- i) Proposed rear lot catchbasins, leads, top elevations and inverts;
- j) Typical sections for all proposed drainage courses and swales;
- k) Existing surface drainage features such as ditches, channels or swamps;
- l) For each lot, a proposed drainage type shall be specified;
- m) Typical detail drawings of proposed drainage types as per Town of Lincoln standards shall be included;
- n) All proposed embankments with hatched lines and proposed top and toe of embankment elevations and degree of slope, i.e. 3:1, 4:1;
- o) Location of all proposed retaining walls and proposed elevations including cross-sections;
- p) Location of all street catchbasins;
- q) Any additional plans, sections and details that may be required for drainage courses and erosion protection, irregular or steep topography, and screening and noise abatement as may be requested by the Town.

2.4.5 Sanitary Drainage Area Plan

The sanitary drainage area plan shall be to a scale of 1:500, showing the following:

- a) Proposed storm sewers, manholes and appurtenances, indicating grade, pipe size, type of pipe, lengths and directions of flow;
- b) Ditches and culverts, where required, showing all necessary information as above;
- c) Drainage areas within the subdivision and the limits of areas outside the plan draining into the proposed system;
- d) Area in hectares, direction of flow and runoff coefficient shall be indicated on all drainage areas.

2.4.6 Storm Drainage Area Plan

The storm drainage area plan shall be to a scale of 1:500, showing the following:

- a) Major storm system flow route along streets and easements including controlling elevations, grades, direction of flow and sizes of conduits and swales incorporated in the system;
- b) Limits of area outside the plan draining through the proposed major system;
- c) Drainage areas within the subdivision and the limits of areas outside the plan draining into the proposed system;
- d) All existing drainage channels and the method of incorporating these channels into the proposed major system;
- e) Location of catchbasins and other stormwater management facilities.

2.4.7 Plan and Profiles of Road

Plan and profile drawings must be drawn for all streets within the subdivision as well as for any service easements.

All chainages shall be calculated along the street centrelines. There must be at least two ties provided per sheet to determine the relationship of the road centreline to the property bars.

All appurtenances and construction details are to be referred to applicable Town Standard Drawings or Ontario Provincial Standard Drawings (OPSD).

Any design details not covered by the above should be put in the form of special design standards and attached with the contract plans with the approval of the Public Works Director or designate.

Plan and profile drawing shall be drawn at a minimum horizontal scale of 1 to 500 and at a minimum vertical scale of 1:50, and shall show the following:

- a) Existing and proposed sewer, giving for each section the size, class, pipe grade, and bedding requirements;
- b) All sewer appurtenances. The manholes must be numbered on both the plan and profile. Designation between sanitary manhole numbers and storm manhole numbers must be shown;
- c) Details of manholes such as number, location, standard, details and grate elevations should be shown;
- d) All manhole inverts must be given and adequately described on the profile;
- e) Existing ground profile is to be indicated as a broken line;
- f) Proposed road profile (top of pavement), giving grades, chainage of P.V.I.'s and vertical curve data are to be shown;
- g) Radius and angle of intersection should be shown for all horizontal curves.
- h) Chainage of B.C., E.C. and P.I., etc. is to be shown on the plan and indicated as such;
- i) The names of streets are to be given outside and above the road allowance;
- j) Curb radii must be given at all intersections and on bends;
- k) Location and description of the nearest benchmark on each drawing.

2.4.8 Construction Details

Any particular detail drawing referenced on any of the preceding drawings or any additional particular detail drawing required by the Public Works Director or designate.

2.4.9 Street Lighting Plan

The street lighting plan shall be to a scale of 1:500, showing the following:

- a) Roads, lots and their numbers;
- b) The position of all new light standards and cables within the development;
- c) The position of existing light standards surrounding the development and their relation to the proposed work;
- d) A detail of, and tabulated specifications for the type of luminaire proposed.

2.4.10 Streetscape/Traffic Plan

The streetscape/traffic plan shall be to a scale of 1:500, showing the following:

- a) Plantings (i.e. trees, shrubs, etc.);
- b) Fences;
- c) Roads, sidewalks & walkways;
- d) Streetlights;
- e) Transformers;
- f) Driveways;
- g) Pavement markings and signage;

- h) Parking spaces- Designers are advised that for the purpose of assessing available on-street parking spaces shall be a minimum of 2.5m wide by 7.0m long. Off-sets from curb cuts and fire hydrants shall conform to the latest version of the Town's Traffic By-Law, as amended from time to time. On-street parking shall be provided at a rate of 1 space for every 2.5 units, unless otherwise approved by the Director of Planning and Development.
- i) Fire hydrants;
- j) Super mail box locations;
- k) Noisewalls;
- l) Typical building elevations;
- m) Any other special features particular to the development.

2.4.11 Draft Plan of Subdivision

Where applicable, three hard copies and one electronic file (*.DWG format) of the draft plan of subdivision, in a form acceptable to the Town of Lincoln and the Regional Municipality of Niagara, are to be submitted to the Town of Lincoln.

2.5 Preparation of Development Agreement

Prior to the preparation of the draft agreement, the Town must be in receipt of the following:

- a) Three (3) complete sets of the approved construction drawings;
- b) A detailed cost estimate prepared by the consulting firm for all services to be constructed;
- c) A breakdown of the number of units proposed within the development: i.e. single family units, detached units, etc.;
- d) The name, address and telephone number of the subdivider's lawyer/agent;
- e) The name of the person and/or company with whom the development agreement will be executed;
- f) Ministry of Environment certificates of approval;

A report regarding the subdivision agreement will be prepared by the Town of Lincoln Public Works Department and forwarded to the Public Works Committee for consideration. The Clerk and Public Works Director will decide whether the agreement requires review by the Town's solicitor prior to finalizing the agreement and obtaining Council approval for execution of the agreement.

2.6 Commencement of Construction

Prior to commencement of works a proposed construction schedule for all construction activities is to be provided to the Town's Public Works Department for approval. During the progress of the work, any proposed revisions to the original schedule will require approval of the Town.

2.6.1 Pre-construction Meeting

A pre-construction meeting with representation from the developer, consulting firm, contractor, utility companies and Public Works staff shall be held for the purpose of coordinating all phases of construction relating to the development project. Prior to holding a pre-construction meeting, the Town must have the following in its possession:

- a) Three (3) copies of the executed Development Agreement;
- b) All required securities;
- c) Two (2) copies of the final construction specifications/contract documents;
- d) Three (3) complete sets of the approved drawings.

2.7 "As-Built" Information Requirements

2.7.1 General

For all projects detailed "as-built" information should be gathered by the consultant, both during and after construction. For all subdivisions "as-built" information is required in two separate formats as follows:

2.7.2 "As-Built" Location Plans

Prior to preliminary acceptance of services, the "as-built" location plans are to be completed and submitted to the Town's Public Works Department showing all necessary details for underground service installations.

The plans would normally be derived using the plan portion of the plan/profile sheets.

Two (2) copies of each location plan are to be submitted as well as on electronic copy.

As-built location plans should show the following:

- a) Sanitary services
 - i) Location of service tie connections at the mainline sewer are to be dimensioned along the mainline sewer from each manhole;
 - ii) Location of services at street line shall be dimensioned from the lot corners and the elevation of the service invert at street line is to be recorded.

- b) Storm services and catchbasin leads
 - i) Location of service and catchbasin lead tie connections at the mainline sewer are to be dimensioned along the mainline sewer from each manhole;
 - ii) Location of services at street line are to be dimensioned from the lot corners and the elevation of the service invert at street line is to be recorded;
 - iii) Catchbasin locations are to be dimensioned as a distance along the storm sewer from the nearest manhole and the elevation of the catchbasin rim and lead invert recorded.

- c) Watermain valves, tees and appurtenances and water services
 - i) The location of watermain valve box and valve chambers are to be dimensioned up or down the road from the nearest manhole and an offset distance from the centreline of the road or back of curb;
 - ii) Mainline tees and appurtenances are to be dimensioned along the alignment of the main from the nearest valve;
 - iii) Water service main stops are to be dimensioned along the alignment of the water main from the nearest valve and curb stops and boxes are to be dimensioned from lot corners.
 - iv) In the event where prior approval has been given, where watermains are not within road allowances or near sewers, swing ties from permanent existing structures shall be used.

2.7.3 "As-Built" Drawings of Subdivision

"As-built" drawings constitute the original engineering drawings which have been revised to show "as-built" conditions. The "as-built" drawings shall be submitted to the Town for their permanent records in an electronic file format (*.DWG) and a hard copy format.

"As-built" drawings are to be submitted to the Town's Public Works Department for checking and microfilming purposes no later than six months after preliminary acceptance of top asphalt. Original

design information (inverts, grades, etc.) is to remain on drawings but crossed out, with as-built information shown adjacent to original information;

The following information is required with the “as-built” submission:

- a) Percent grade – sewers;
- b) Percent grade – roads;
- c) Percent grade – watermains, where necessary;
- d) Invert elevations – sewers at manholes, at plugs for future extensions;
- e) Top of pipe and/or invert elevations – watermains, where necessary, e.g. where watermain has been varied from normal depth requirements, in field, to avoid conflict with other buried services;
- f) Top of watermain and sanitary sewer at centreline of creek crossing;
- g) Pipe type, class and bedding;
- h) House connections – sanitary, storm and water;
- i) "As-built" drawings (shown in revision column with date);
- j) Registered Plan Number is to be shown on plan view of each drawing including general plans;
- k) Lot and block numbers shall be in conformity with the registered plan;
- l) Street names shall be in conformity with the registered plan or as approved by the municipality;
- m) All design sheets for services are to be recalculated to conform to as-built measurements and submitted in duplicate to the Town for permanent record.

2.8 Lot Grading Certification

In all new developments, the Town requires that the developer provide a grading certificate, prepared by the consulting firm, certifying grading has been completed in accordance with the approved grading plan. Minor variations will be allowed provided they do not present problems for adjoining properties.

Since the overall grading plan is general in nature, it will be necessary that a detailed grading plan be submitted at building permit stage for each lot in a subdivision showing house types, proposed elevations, swales, etc. (see Town standard drawings for examples).

It should be noted that the finished lot grading certificate should not be submitted until the lot or block is graded and sodded.

3.0 Roadways

3.1 Road Design

3.1.1 General

Road classification shall be subject to the approval of the Public Works Director or designate.

Arterial roads are intended to carry larger volumes of traffic, moving at medium to high speeds. Arterial roads serve the major traffic flows between the principal traffic generators and connect with collectors and freeways. In the Town of Lincoln any roadway under the jurisdiction of the Province of Ontario or the Regional Municipality of Niagara is designated as an arterial road. Design of arterial roadways shall meet the requirements of the controlling authority.

Collector roads provide for both traffic service and land access. The primary traffic service function is to carry traffic between local streets and arterial roadways. The Town of Lincoln classifies collector roads as any roadway which, in the opinion of the Town:

- a) Will serve as access to 100 or more homes;
- b) Will serve as a traversing route for residents outside of the subdivision.

A local road's function is to provide for land access to those properties, which directly front on it.

3.1.2 Geometric Design Standards

The following criteria should be used when designing roads for new developments. However, it is acknowledged that in some areas of the municipality topographic constraints may exist that may make the use of portions of these criteria impractical. In these instances reference should be made to the various Geometric Design Guidelines published by the Transportation Association of Canada for design recommendations. Any variance to the following criteria will require approval of the Director of Public Works or designate.

	Local Road	Collector Road
Minimum grade	0.5%	0.5%
Maximum grade	8.0% (5.0% Desirable)	6.0% (5.0% Desirable)
Maximum grade of through roads at intersections	3.5%	3.0%
Desirable maximum grades for stop roads at intersections	2.5%	1.5%
Minimum curb radius at local road	9.0m	10.5m
Minimum curb radius at arterial road	15.0m	15.0m
Minimum curb radius at collector road	10.5m	10.5m
Cul-de-sac minimum curb radius	12.0m (15.0m industrial areas)	n/a

	Local Road	Collector Road
Right-of-way width	20.0m	20.0m, 23.0m, 26.0m
Minimum centreline radius	60.0m (except at 90° corners)	85.0m
Design speed	50Km/h	60Km/h
Minimum stopping sight distance	65.0m	85.0m
Vertical curve: K for sag	12	18
Vertical curve: K for crest	8	15
Superelevation	None	None
Intersection angle	70° - 100° at local 80° - 100° at collector & arterial	80° - 100°

- a) Vertical curves are required for changes in grade greater than 1%.
- b) The minimum length of each grade is 6 metres. A "Cul-de-sac" is to have a minimum grade of 0.50% around the longest curb, to ensure adequate surface drainage.
- c) At the intersection of two roads, any transition of the minor classification road shall not interfere with the normal cross-fall of the major road. A 1% to 2% back-fall grade shall be provided on all road profiles where local streets intercept with major roads. The back-fall grade shall be from the crown of the major road to the end of curve or first catchbasin on the local road.

3.1.3 Drainage Design Standard

The following frequency based criteria shall be used for the design of road drainage systems:

Road Classification	Bridge & Culvert Capacity	Storm Drainage System	
		Minor System	Major System
Urban arterial/collector	100 Yr	5 Yr	100 Yr
Rural arterial/collector	50 Yr	5 Yr	100 Yr
Local	25 Yr	5 Yr	100 Yr
Depressed roadways (subways etc.)	-	25 Yr	-

3.1.4 Road Pavement Design

Road pavement for local and collector roads will be as per Town Standard Drawings.

The pavement design for arterial roads will be considered on an individual basis. The composition and construction thickness of the road pavement shall be designed based upon the following factors:

- a) Mechanical analysis of the subgrade soil;
- b) Drainage;

- c) Frost susceptibility;
- d) The future volume and class of traffic expected to use the pavement.

Pavements shall be designed for a minimum ADT - 1000 vehicles and an anticipated life of 25 years.

Tack coat must be installed prior to any application of any surface or binder course asphalt as per NPSCD's.

3.1.5 Binder Course Asphalt-Temporary Ramping

When the surface course asphalt is to be delayed or placed the following year, temporary asphalt ramps shall be placed at all wheelchair ramps and driveway approaches. The top of the temporary asphalt ramps shall be placed so as to be flush with the lower edge of curb at the depressed portion of all wheelchair ramps and driveway approaches. The temporary asphalt ramps shall be removed at the time of placement of the surface course asphalt.

3.1.6 Road Allowance Cross-Section

The typical road allowance cross-section shall be as per the Town's Standard Drawings. Details shall be provided for any special provisions required due to unique physical conditions on the site, or for existing or future design conditions, such as retaining walls, slope protection, culverts, bridges or special cross-fall conditions.

3.1.7 Road Sub-Drains

In general, sub-drains will be required to run continuously along both sides of all roads, as per the Town's Standard Drawing; however, the Town will consider reducing sub-drain requirements for a particular development where a qualified soils consultant indicates that there will be no adverse effects to the road either during or after construction.

In all cases, sub-drains will be required for a minimum length of 6 metres on the upstream side of all catchbasins.

3.2 Curb

Curb as shown on Town Standard Drawings, shall be used on local streets. "Capping" of curb depressions will not be permitted.

Sawcutting of curb depressions will be allowed. Mountable curbs as per Town Standard Drawings may be used with the approval of the Director of Public Works or designate.

Two stage curb construction in accordance with Town Standard Drawings may be used with the approval of the Director of Public Works or designate.

3.3 Sidewalks

Concrete sidewalks as per Town Standard Drawings shall be considered on both sides of all arterial roads and collector roads, and on one side of local streets, such that no lot is further than 150 metres from a sidewalk.

The developer should discuss the location and requirement for sidewalks with the Town of Lincoln Public Works Department prior to commencement of detailed design.

Sidewalks shall install Tactile Warning Plates within the sidewalks at all road crossings as per NPSCD's.

3.4 Boulevards

All boulevards shall be sodded on a minimum of 100mm of topsoil from curb line to property line and shall be kept free of rubbish and other materials during the development.

3.5 Driveway Entrances

The subdivider shall be required to provide for the excavation, stoning and maintenance in good condition of each driveway from the travelled portion of the road to the lot line, until the roadways have been completed. The developer shall, upon the construction of the sidewalk, construct, at their own expense, a concrete or asphalt driveway entrance for each lot, from the travelled portion of the roadway to the sidewalk, extending the full width of the driveway.

The following are the minimum requirements:

- a) Residential driveway
 - i) 50mm HL3 surface course
 - ii) 200mm granular 'A' base

- b) Light industrial, commercial and apartment driveway:
 - i) 40mm HL3 surface course
 - ii) 50mm HL8 base course
 - iii) 300mm granular 'A' base

- c) Heavy industrial driveway:
 - i) 40mm HL3 surface course
 - ii) 75mm HL8 base course
 - iii) 375mm granular 'A' base

The width of curb cut-out for residential driveways shall be as per Town Standard Drawings. Where mutual driveways are constructed between two adjoining properties, the curb cut-out shall be continuous.

The maximum grade permissible for an access driveway, from the sidewalk to the garage shall be 7%. This maximum grade is not recommended and should be employed only in exceptional cases where physical conditions prohibit the use of lesser grades. There shall be a minimum grade of 2% from the street line to the curb line.

The radius of curvature from the road into apartment, commercial and industrial driveways shall be designed to accommodate the anticipated vehicular traffic without causing undue interference with the traffic flow on the street.

Minimum entrance requirements for apartment, commercial and industrial sites are as per Town Standard Drawings.

One entrance will only be permitted for residential driveways within the urban boundary unless additional is justified and approved by the Director of Public Works.

3.6 Daylighting

Daylighting triangles are required for all new roads. The size of daylighting required will be governed by the major road. The minimum daylighting requirements will be as listed below, however, the Director of Public Works or designate may require additional daylighting or allow curvilinear daylighting in unique circumstances.

- a) local roads – 4.5m
- b) collector roads – 7.0m
- c) arterial roads – to be determined on an individual basis in accordance with the latest edition of the Geometric Design Guidelines published by TAC.

3.7 Footpaths and Walkways

- a) Walkways and Footpaths are to be in accordance with Town Standard Drawings;
- b) Where footpaths or walkways run between residential lots, fencing along property lines on both sides of the path or walk must meet height requirements of the local by-law for swimming pool installations;
- c) Where walkway and/or footpaths are located adjacent to private property, gates for entrances into the municipal parkland will not be permitted.

3.8 Street Name and Traffic Sign Requirements

The owner shall pay the cost of the supply and installation of permanent street name and traffic signs. Sufficient traffic control signs will be required to ensure safe and efficient flow of traffic, as determined by the Director of Public Works or designate. Signs shall be installed by Town forces.

All street name signs shall be conventional, double-faced extruded reflective metal signs, in accordance with current Ontario Provincial Standard Specifications and the Uniform Manual of Traffic Control Devices.

All street names must be approved in advance by the Town of Lincoln Planning Department. A street name list may be used to select appropriate street names.

3.9 Trees

The developer shall supply and plant trees within the subdivision.

All trees shall be at least 2.1 metres in height and 50mm calliper, of No. 1 quality in accordance with the standards of the Canadian Nurserymen's Association.

Trees shall be planted in accordance with Town Standard Drawing at locations as specified on the Streetscape/Landscape Plans as approved by the Public Works Director or designate. As a guideline, the following minimums apply:

For standard width single lots: one tree shall be required on every lot frontage and two trees shall be required on corner lot side frontages.

For semi-detached and multi unit blocks: trees shall be required such that one tree has been provided for every 15 metres of frontage. Trees may be planted in clusters to achieve this density.

For oversize single lots: I) one tree shall be required on every lot frontage and II) two trees on every corner lot side frontage, plus III) additional trees totalling 50% of I) and II) must be provided.

All trees that fail to grow or die within the two year maintenance period and prior to the development being assumed by the municipality shall be replaced at the developer's expense.

The following is a list of trees approved for boulevard planting. Use of plant materials which are not listed here will also be considered on an individual basis.

- a) *Nyssa Sylvatica* – Black Gum
- b) *Quercus Robur* “Fastigiata” – Columnar English Oak
- c) *Amelanchier Aborea* – Downy Serviceberry
- d) *Cornus Controversa* – Giant Dogwood
- e) *Ginko Biloba* – Ginko
- f) *Gleditsia Triancanthos* “Inermis” – Honeylocust
- g) *Ostrya Virginiana* – Ironwood
- h) *Syringa Reticulata* – Japanese Lilac
- i) *Gymnocladus Dioica* “Espresso” – Kentucky Coffeetree
- j) *Tilia Cordata* – Littleleaf Linden
- k) *Platanus x Acerifolia* – London Planetree
- l) *Celtis Occidentalis* – Northren Hackberry
- m) *Acer Rubrum* – Red Maple
- n) *Quercus Rubra* – Red Oak
- o) *Amelanchier Laevis* – Smooth Serviceberry
- p) *Liriodendron Tulipifera* – Tulip Tree
- q) *Liriodendron Tulipifera* “Fastigiata” – Columnar Tulip Tree
- r) *Quercus Alba* – White Oak

3.10 Utility Installations

Location and installation details for all utilities must be approved by the Director of Public Works or designate prior to the installation. All utilities to be constructed in existing municipal roads will require a Utility Permit.

All utility trenches within the road allowance are to be in accordance with Town Standard Drawings.

All control mechanisms, hydro transformers, etc. are to be housed in underground vaults, unless otherwise approved by the Public Works Director or designate.

3.11 Street Lighting

The subdivider shall arrange with the local hydro authority for the installation of all lighting facilities, including poles, conduits, lamps and control mechanisms. The type, number of lights and their location together with the estimated cost of the total installation thereof, must be approved by the Director of Public Works or designate. The subdivider shall supply the local electrical supply authority with easements wherever they are required.

3.11.1 General

- a) This work shall include the supply and installation of light standards complete with davit arms, luminaires, lamps, individual photo-electric controllers and riser wires, connected complete from

the luminaire to the pole handhole. Underground supply and connection within the light standard handhole will be carried out by the local electrical supply authority.

- b) Pole, arm and luminaires will be in accordance with Town Standard Drawings.
- c) All streetlights shall be installed so that they may be isolated from the main electrical supply for routine maintenance (i.e. breaker, isolation pedestal) to the satisfaction of the Director of Public Works or designate.

3.11.2 Criteria for Local Residential Streets

(Residential and Industrial Roads)

- a) The average foot candle value to be .4 foot candles.
- b) The lowest foot candle value at any point on the pavement should not be less than one-sixth the average foot candle value.
- c) The lights should be suitable for underground supply at 120 volts.
- d) Individual photo-electric controls only.
- e) Where possible, pole locations are to be placed opposite lot lines.
- f) No street light should be placed within 5 metres of a transformer.
- g) Wherever possible, street light pole locations should be adjacent to main cable trench.
- h) Street light poles to be located 3.5 metres from property line.
- i) Poles should not be located between two immediately adjacent driveways, if possible.

3.11.3 Criteria for Collector, Residential

- a) The average foot candle value to be .6 foot candles.
- b) The lowest foot candle value at any point on the pavement should not be less than one-fourth the average foot candle value.
- c) The lights should be suitable for underground supply at 120 volts.
- d) Individual photo-electric controls only.
- e) Poles to be located 3.5 metres from property line.
- f) Wherever possible, street lighting pole locations should be adjacent to main cable trench.

3.11.4 Criteria for Arterial, Residential

Design of street lighting for arterial roadways shall meet the requirements of the agency having control over the roadway.

All designs shall be in accordance with the "Guide for Design of Roadway Lighting" as developed by the Transportation Association of Canada (TAC).

3.12 Electrical Distribution

Design and installation of the electrical distribution system for all proposed developments is to meet the requirements of the local hydro authority. Underground street wiring and wiring to the lots and houses are mandatory. In circumstances where underground wiring is not practical, an alternative may be considered by the Director of Public Works or designate.

3.13 Traffic Signals

The requirement, location and installation details for traffic signals shall be made/approved by the Director of Public Works or designate. In general, traffic signals shall be designed in accordance with the Uniform Manual of Traffic Control Devices and the Ontario Provincial Standard Specification.

3.14 Emergency/Fire Access Requirements

Emergency accesses shall have a minimum unobstructed easement width of 6.0 metres. A minimum travel width of 3.5 metres shall be provided to the satisfaction of the Town Fire Department.

3.15 Traffic Calming Measures

The primary function of Traffic Calming measures is to improve the liveability of neighbourhoods and improve public safety by reducing vehicle speeds, vehicle volumes and collision frequency. In addition, well-designed and landscaped Traffic Calming measures can enhance a neighbourhood's appearance and the quality of life for its residents.

Traffic calming measures will be required as part of the original design of roadways. The developer shall be responsible to implement and maintain traffic calming measures up until Assumption.

3.16 Pavement Markings

Pavement markings shall conform to the Ontario Traffic Manual Book 11 (latest edition). All markings to be placed after installation of base course asphalt. Pavement markings shall be applied with a double coat with glass beads after the placement of top course asphalt. Prior to maintenance and/or assumption, markings may need to be reapplied.

4.0 Sanitary Drainage Systems

4.1 Design Flows

For residential areas sanitary design flows shall be calculated as follows:

$$Q = \frac{P \times q \times M}{86.4} + (I \times A)$$

Where: P = design population in thousands
 q = avg. daily per capita flow in l/cap/day
 M = peaking factor = $1 + \frac{14}{4 + P^{0.5}}$
 I = infiltration in l/ha/sec
 A = tributary area in ha
 Q = design flow in l/sec

- For design purposes the following population densities and flow allowances shall be used:
 - Single Family Units – 2.8 persons/unit
 - Semi/Townhouse Units – 2.2 persons/unit
 - High density Units (Apartment) – 1.7 persons/unit
 - Mixed Used – 2.5 persons/unit

Flow Allowances

- Commercial Flows
 - 310 L/job/day; or
 - 5 L/m²/day
- Residential Flow
 - 255 L/cap/day
- Wet Weather Flow Allowance
 - 0.286 L/s/ha for new development areas
 - 0.4 L/s/ha for existing areas

Note: At the point of assumption of sanitary sewers, the maximum allowable infiltration is 0.018 l/s/ha.

For calculation of sewage design flows for heavy industrial or commercial areas reference should be made to the latest editions of the Ontario Ministry of the Environment's "Guidelines for the Design of Water Storage Facilities, Water Distribution Systems, Sanitary Sewage Systems and Storm Sewers".

4.2 Sewer Design

4.2.1 Hydraulic Calculations

- a) Sewer capacities can be computed using Manning's Formula on the basis of sewer pipe flowing full; however the "actual" flow depth and velocity at the design flow shall also be calculated and taken as the basis for design.
- b) Pipe sizes shall not decrease from a larger size upstream to a smaller size downstream, regardless of slope.
- c) All calculations shall be summarized utilizing standard Town forms.

4.2.2 Roughness Coefficients

For smooth wall concrete, polyvinyl chloride and polyethylene, a minimum value of $n = 0.013$ shall be used.

4.2.3 Velocity and Slope

- a) The minimum velocity in a sanitary sewer shall be 0.60m/s, the maximum velocity shall be 3.00m/s.
- b) The minimum slope in the highest or starting leg of a sanitary sewer shall be 1.0%.

4.2.4 Minimum Size

The minimum size for a local sanitary sewer will be 200mm diameter.

4.2.5 Minimum Depth and Clearance

- a) Depth is measured from the final centreline finished road elevation to the top of the sanitary sewer. For residential, commercial and institutional areas, the minimum depth is 2.75 metres. For industrial areas, the minimum depth is 2.15 metres. In all cases, the proposed sanitary sewers shall be installed at sufficient depth to service lands external to the site as required by the Town.
- b) Generally, a minimum clearance 0.25 m shall be provided between the outside of the pipe barrels at the point of crossing for storm and sanitary sewers. Generally, a sanitary sewer shall pass under a watermain and a minimum clearance of 0.50m shall be provided at the point of crossing. In the event the clearances cannot be obtained, the criteria contained in Section 6 of this manual will govern.

4.2.6 Location

Sanitary sewers shall be located on the north and east side of the road allowance, 2.0 metres from the centreline as shown on Town Standard Drawings. Common trenching will only be considered for exceptional sub surface conditions (e.g. rock) and any non-standard arrangement will be subject to the approval of the Public Works Director or designate.

4.2.7 Manholes

- a) In general, manholes shall be constructed as per Town Standard Drawings; however, it is the responsibility of the designer to analyze each application of the standard (i.e. soil conditions, loadings, etc.) to determine structural adequacy. In cases where the standards can not be used manholes shall be individually designed and detailed.
- b) Manholes shall be provided at each change in alignment, grade, and pipe material and at all junctions, except where radius pipe is used.
- c) Generally, manholes shall be spaced at:
 - i) A maximum of 100 metres for pipe sizes 200mm diameter to 750mm diameter.
 - ii) A maximum of 120 metres for pipe sizes 825mm diameter to 1200mm diameter.

- d) The type and size of manholes shall be specified on the profile and a detail of the benching is to be shown on the plan portion of the drawing for cases when the benching differs from the standard drawings.
- e) A waterproofing membrane or petrolatum tape shall be applied externally around all joints of maintenance holes and chambers, including all moduloc, and is to be overlapped halfway up the structure frame. The membrane shall be installed as per manufacturer’s specifications and protected during backfill operations.
- f) All manhole chamber openings shall be located on the upstream side of the manhole.
- g) The maximum change in the direction of flow in any sanitary sewer manhole shall be 90 degrees. A change of flow direction at acute interior angles shall not be permitted.
- h) The maximum drop allowed across a manhole is 0.9m. If the design of the sewer system is such that the difference in elevation between the manhole inlet and outlet will exceed 0.9m, then a drop structure will be required.
- i) When pipe size does not change through a manhole and the upstream flow velocity does not exceed 1.5 m/s, the following allowances shall be made to compensate for hydraulic losses:

Alignment Change	Drop Required
Straight run	Grade of sewer
15° – 45°	30mm
45° – 90°	60mm

When the flow velocity exceeds 1.5 m/s, the drop required shall be calculated.

- j) For all junction and transition manholes, the drop required shall be calculated.
- k) The obvert(s) on the upstream side of a manhole shall in no case be lower than the obvert(s) on the downstream side of the manhole.
- l) Safety gratings shall be required in all manholes greater than 5.0 metres in depth. Safety gratings shall not be more than 5.0 metres apart and installed at the halfway point. Safety gratings shall be constructed in accordance with OPSD.
- m) OPSD 701 series with watertight connections KOR-N-Seal type or approved equivalent.
- n) All manholes shall be benched as per OPSD 701.021.

4.3 Easements

The minimum width of easements for pipes shall be determined to account for the number of pipes, pipe size, depth and excavation of open cut method. In no case shall the easement width be less than 3.0 metres.

The developer must grant permanent easements for any drainage works which are not within the road allowance, to the Town and a "Restriction of Use" clause shall be registered on title restricting landscaping and fencing activities.

4.4 Pipe Design

- a) All pipe and embedment material selection shall be supported with appropriate structural design calculations. In the case of flexible pipe materials, long term deflection will be limited to 5% of the diameter. Both dead and live loads shall be considered.
- b) The class, type of pipe and type of pipe bedding shall be shown on the profile for each length of sewer.
- c) The use of radius pipe or deflected pipe will be permitted to achieve changes in horizontal alignment for sewer sizes 1050mm diameter and larger. The minimum radius allowed for various pipe diameters shall be as detailed in the manufacturer's specifications. When pipes are deflected at the joints, the angle of joint displacement shall not exceed 3 degrees.
- d) No service connections shall be permitted to sanitary sewers exceeding 7.60 metres in depth. Depth is measured from the final centreline finished road elevation to the top of the sanitary sewer.

4.5 Pipe Materials

4.5.1 Sanitary Sewer

- a) Sanitary sewers may be constructed of polyvinyl chloride, concrete, or polyethylene pipes.
- b) All pipe used for sanitary sewer shall have a smooth interior wall.
- c) For main sewers, the Standard Dimension Ratio (SDR) of the PVC pipe shall not exceed SDR 35.
- d) For service connections the Standard Dimension Ratio of the PVC pipe shall not exceed SDR 28.
- e) Exterior "profiled" wall polyvinyl chloride or polyethylene pipe will not be generally used for sanitary sewers, except in certain exceptional circumstances, as approved by the Director of Public Works or designate.
- f) Polyvinyl Chloride and Polyethylene pipe can be used for diameters up to 600mm when installed under roadways. In other locations this limit may be extended to 900mm diameter upon the approval of the Director of Public Works or designate.
- g) All pipe materials and associated appurtenances must meet current relevant Ontario Standard Specifications (OPSS). Where no specification exists, the current Canadian Standards Association (CSA) or American Society for Testing and Materials (ASTM) specification will govern.

4.6 Sanitary Sewer Service Connection

4.6.1 General

All sanitary sewer service connections for single and semi-detached dwellings shall be individual services.

The connection to the main sewer shall be made with an approved manufactured tee or approved saddle.

No service connection of a size greater than half the diameter of the mainline sewer will be cut into the main, manufactured tee to be installed.

All sanitary service connections shall have a 100mm cleanout “wyed” in at property line with buried locate ball (OMNI Ball Marker Model 162, Green) next to cap. Buried no more than 150mm below finished grade.

The colour of the sanitary service connection pipe will be green.

Clean out to be installed at the property line as per DPW 505.

In new developments, the service connections shall be installed in accordance with the Town Standard Drawings terminating at the property line. **Under no circumstances will roof water leaders or sump pump/foundation weepers be permitted to be connected to the sanitary sewer.**

4.6.2 Pipe Size

- a) Service connections for single family and semi-detached units shall be 125mm in diameter. Clean outs shall be placed every 15 metres.
- b) Service connections for multiple family, commercial, institutional areas are to be sized individually according to the intended use.

4.6.3 Depth

The depth of the service connections for single family units and semi-detached units, at the street line, measured from the final centreline road elevation shall be:

- a) Minimum - 2.50 metres
- b) Maximum - 3.00 metres

Risers shall be used when the invert depth of the sewer main exceeds 4.60 metres. The riser connection shall not exceed 3.0 metres in depth.

4.6.4 Velocity and Grade

- | | |
|-------------------------------|------------|
| a) Minimum low flow velocity | 0.60 m/sec |
| b) Minimum grade - 125mm dia. | 2% |
| c) Maximum grade | 8% |
| d) Minimum grade - 150mm dia. | 1% |

4.6.5 Sanitary Sewer Connections to Multiple Family Blocks

Manhole shall be required to be located either on private property, 1.50 metres from property line to centre of rim, or on the municipal main.

4.6.6 Sanitary Sewer Connections to Commercial and Industrial Blocks

A manhole shall be required to be located on private property 1.50 metres from property line to centre of rim.

4.6.7 Materials for Sanitary Sewers Service Connections

- a) Sanitary sewer service connections may be constructed using any of the materials outlined in Section 4.5 except for polyethylene, which is not listed as an acceptable material under The Plumbing Code.
- b) In order to avoid cross connections, all pipe used for residential sanitary laterals shall be the colour green.

4.6.8 Location of Service Connections

Sanitary connections shall be located in accordance with the applicable Town Standard Drawing.

4.7 Construction

Construction of all sanitary sewers and service connections shall be in accordance with the current and appropriate Town Specifications and Standard Drawings.

Full time inspection by a qualified Consulting Engineer retained by the Developer is required for the construction of the new sanitary system.

Compaction Reports by a qualified Geotechnical Engineer shall be submitted for pipe bedding and trench backfill at frequencies acceptable to the Town.

All testing shall be conducted under the supervision of the Consulting Engineer in accordance with the Town requirements to the satisfaction of the Director of Public Works.

The sanitary sewers shall be videoed by closed circuit television and a copy of the video and inspection report (as per NASSCO PACP, LACP, MACP -Latest Version) to be forwarded to the Town prior to issuance of the Completion Certificate of Primary Services by the Director of Public Works.

4.8 Sanitary Forcemains and Siphons

Forcemains and siphons will only be considered in exceptional circumstances when no other feasible option exists. Any proposed use must be supported by a thorough technical analysis by a consultant with significant experience in designing these systems.

The requirements for each proposed use will be assessed by the Director of Public Works or designate on an individual basis.

5.0 Storm Drainage Systems

5.1 Stormwater Management

Determination of stormwater management quantity requirements for both the major and minor drainage system for development shall conform to the contents of the latest Town of Lincoln's "Storm Drainage Policies and Criteria" and/or the requirements of any Master Drainage Plan that may exist for a particular watershed.

For stormwater quality criteria reference should also be made to the latest edition of the Ontario Ministry of the Environment's "Stormwater Management Practices, Planning and Design Manual".

The developer and/or his consultant shall meet with the Town's Public Works department prior to commencement of detailed design to establish the acceptable methodology for determination of stormwater design flows, etc. required by the Town.

5.2 Rational Method

5.2.1 General

The rational method is acceptable for determination of most storm sewer design flows. For this purpose, the following section may be used.

Generally all storm sewers shall be designed according to the rational formula as follows:

$$Q = 2.78 AiR$$

Where: A = Drainage area in hectares
i = Average rainfall intensity - mm/h
R = Runoff coefficient
Q = Runoff quantity in 1/s

5.2.2 Watershed and Drainage Areas

The watershed area shall be determined from contour plans and shall include all areas that naturally drain into the system and shall also consider all lot grading plans for proposed developments.

A plan of the watershed area shall be prepared and shall include all affected streets, lots and watercourses. The proposed storm sewer system shall be shown on this plan including each manhole numbered consecutively for design reference. Manholes shall generally be located at each and every change of pipe size, grade and alignment.

Manholes shall be the tributary points in design. The areas tributary to each manhole shall be clearly outlined on the storm drainage area plan with the area in hectares (to the nearest tenth) and runoff coefficient shown in a circle.

In cases where areas of different runoff coefficients are tributary to one manhole, the areas tributary to the manhole shall be individually outlined. The tributary area and runoff coefficient for each area shall be shown as set out above.

In determining tributary areas to manholes, the proposed grading of lots should be taken into account.

In the case of large tributary areas under single ownership, such as shopping centres, apartment developments, schools, etc., the design shall be prepared on the basis of the whole area being tributary to a manhole in an abutting storm sewer. When more than one sewer connection will be necessary to serve the property in question, the appropriate area tributary to each sewer connection shall be clearly shown and taken into account in the design of the storm sewer.

In lieu of precise information on development of the whole or any part of a watershed area, the latest approved zoning by-law and plans shall be used to select the correct values of the runoff coefficients to be used in the design and to determine the specific areas where they will apply.

5.2.3 Rainfall Intensity

- a) The values of the rainfall intensity shall be determined using the approved Rainfall Intensity Duration Curve for Vineland Station.
- b) For new developments return frequency values for design shall be as follows:
 - i) Minor System – 5 year;
 - ii) Major System – 100 year
- c) In addition, reference should be made to Section 3 of this manual for frequency bases criteria governing the design of road drainage systems.

5.2.4 Runoff Coefficients

Values for the runoff coefficient "R" shall be approved by the Public Works Director or designate. Listed below are the minimum runoff coefficients to be used:

Surface Type or Land Use	Recommended Coefficient
Parks	0.30
Single family residential	0.45
Semi-detached	0.55
Maisonettes, townhouses, etc.	0.70
Apartments, schools, churches, etc.	0.75
Industrial	0.85
Commercial	0.90
Paved areas	0.90

5.3 Sewer Design

5.3.1 Hydraulic Calculations

- a) Sewer capacities can be calculated using Manning's Formula on the basis of the pipe flowing full, however, the "actual" flow depth and velocity at the design flow shall also be calculated and taken as the basis for design.
- b) Pipe sizes shall not decrease from a larger upstream size to a smaller downstream size, regardless of slope.
- c) All calculations shall be summarized utilizing standard Town forms.

5.3.2 Roughness Coefficient

The roughness coefficient to be used for storm sewer pipes shall be:

- a) Smooth wall concrete, polyvinyl chloride and polyethylene; a minimum value of $n = 0.013$, shall be used.
- b) Corrugated wall; according to manufacturers recommendations.

5.3.3 Velocity

The velocity in storm sewers shall be generally limited to a minimum of 0.75 m/s and a maximum of 4.5 m/sec.

5.3.4 Minimum Sizes of Pipes

Sewer Mains	300mm
Catchbasin Connections	200mm

5.3.5 Minimum Depth and Clearance

- a) The minimum cover to the top of the pipe shall generally be 1.4 metres. In all cases, the proposed storm sewers shall be installed at sufficient depth to service lands external to the site as required by the Town.
- b) Generally, a minimum clearance of 0.25m shall be provided between the outside of the pipe barrels at the point of pipe crossing for storm and sanitary sewers. Generally, a storm sewer shall pass under a watermain and a minimum clearance of 0.5m shall be provided. In the event that the minimum clearances cannot be obtained, the criteria contained in Section 6 of this manual will govern.

5.3.6 Location

Storm sewers shall be located on the south and west side of the road allowance, 2.0 metres from the centreline as shown on Town Standard Drawings. Common trenching will only be considered for exceptional sub surface conditions (eg. rock) and any non-standard arrangement will be subject to the approval of the Director of Public Works or designate.

5.3.7 Manholes

- a) In general, manholes shall be constructed as per Town Standard Drawings. However, it is the responsibility of the designer to analyse each application of the standard (ie. soil conditions, loadings, etc.) to determine structural adequacy. In cases where the standards cannot be used manholes shall be individually designed and detailed.
- b) Manholes shall be provided at each change in alignment, grade and pipe material, except where radius pipe is used.
- c) Generally, manholes shall be spaced at:
 - i) a maximum of 100 metres for pipe sizes 300mm diameter to 750mm diameter
 - ii) a maximum of 120 metres for pipe sizes 825mm diameter to 1200mm diameter
 - iii) a maximum of 150 metres for pipe sizes greater than 1200mm diameter
- d) The type and size of manhole shall be specified on the profile and a detail of the benching shall be shown on the plan portion of the drawing for cases when the benching differs from the standard drawings.
- e) All manhole chamber openings shall be located on the upstream side of the manholes.
- f) Storm sewer pipe greater than 525mm shall not be turned more than 90 degrees in any manhole. In cases where there is more than one inlet, no storm sewer greater than 450mm shall be turned at 90 degrees in a manhole.
- g) The maximum change in direction of flow in storm manholes for sewer sizes 1050mm and over shall be 45 degrees.
- h) The direction of flow in any manhole will not be permitted at acute interior angles.
- i) All manholes shall be benched as per OPSD 701.021.
- j) The required drop through all manholes shall be calculated.
- k) The maximum drop across a manhole is 0.90 metre. If the design of the sewer system is such that the difference in elevation between the manhole inlet and outlet will exceed 0.90 metres, then a drop structure will be required.
- l) The obvert(s) on the upstream side of a manhole shall, in no case, be lower than those on the downstream side.
- m) Safety gratings shall be required in all manholes greater than 5.0 metres in depth. Safety gratings shall not be more than 5.0 metres apart and installed at the halfway point. Safety gratings shall be constructed in accordance with the Standard Drawings.

5.3.8 Catchbasins

a) The spacing of catchbasins shall be as follows:

Road Gradient	Maximum Spacing
0.5% to 3%	90m
3% to 5%	75m
5% to 6%	60m

- b) Where changes of grade occur, the average gradient shall determine the maximum spacing.
- c) Catchbasins should not be located within 1.5 metres of a curb depression for a driveway or sidewalk.
- d) At intersections, catchbasins shall be installed so that not more than 15 metres of gutter will drain past the upstream point of tangency.
- e) In sags, when drainage is received from more than one direction, double catchbasins shall be installed and the maximum length of gutter contributing from each side shall be 75% of the spacing permitted above.
- f) Rear lot/yard catchbasins to be installed as per DPW 506. Lead will offset 0.6 metre from the property line, entirely on one lot or block.
- g) Rear lot/yard catchbasin shall be installed with a Birdcage type grate and cover as per OPSD 400.120.
- h) All rear lot/yard catchbasin leads must connect to a roadside catchbasin .
- i) Catchbasins shall conform to the Town of Lincoln Standard Drawings or OPSD.

5.4 Easements

The minimum width of easements for pipes shall be determined to account for number of pipes, pipe size, depth and excavation by open cut method. In no case shall the easement width be less than 3.0 metres.

The developer must grant permanent easements for any drainage works, which are not within the road allowance, to the Town and a "Restriction of Use" clause shall be registered on title restricting landscaping and fencing activities.

<u>Size of Pipe</u>	<u>Depth of Invert</u>	<u>Minimum Width of Easement</u>
rear lot CB leads	up to 3.0m	3.0m
up to 675mm	up to 3.0m	5.0m
750 to 1500mm	up to 3.0m	6.0m
1650mm and up	up to 4.0m	4.0m + 3 times O.D. of pipe

5.5 Pipe Design

- a) All pipe and embedment material selection shall be supported with appropriate structural design calculations. In the case of flexible pipe materials, long term deflection will be limited to 5% of the diameter. Both dead loads and live loads shall be considered.
- b) The class and type of pipe and type of pipe bedding shall be shown on the profile for all lengths of sewer.
- c) All storm sewers shall be located as shown on the appropriate road cross-section standard.
- d) Subject to the approval of the Director of Public Works or designate, radius pipe will be permitted to achieve changes in horizontal alignment. The minimum radius allowed for various diameters of pipe shall be as detailed in the manufacturer's specifications.

5.6 Pipe Materials

- a) Storm sewers may be constructed of concrete pipe, polyvinyl chloride pipe or polyethylene pipe. Corrugated metal piping may be used for culverts.
- b) All pipe used for storm sewer shall have a smooth interior wall.
- c) Polyvinyl chloride and Polyethylene pipe can be used for diameters up to 600mm when installed under roadways. In other locations this limit may be extended to 900mm diameters upon the approval of the Director of Public Works or designate.
- d) All pipe materials and associated appurtenances must meet current relevant Ontario Provincial Standard Specifications (OPSS). Where no such specification exists, the current Canadian Standards Association (CSA) or American Society for Testing & Materials (ASTM) specification will govern.

5.7 Storm Sewer Service Connections

5.7.1 General

In new developments, every lot shall have a service connection and shall be installed in accordance with the Standard Drawings terminating a property line.

The storm sewer connections to the main sewer shall be made with an approved manufactured tee for main sewer sizes up to and including 375mm diameter and in accordance with Town requirements for larger sizes.

The colour of the storm service connection pipe will be white.

Service connections shall not connect into a catchbasin.

5.7.2 Pipe Size

- a) Service connections for single family and semi-detached units - minimum 100mm diameter;

- b) Service connections for multiple family and other blocks, commercial and industrial areas - to be sized individually according to the intended use.

5.7.3 Depth

- a) The depth of service connections at the street line in residential areas, measured from the final centreline road elevation shall be:
 - i) Minimum - 1.80 metres
 - ii) Maximum - 2.50 metres
- b) Risers shall be used when the invert depth of the sewer main exceeds 4.60 metres. Risers shall not exceed 3.0 metres in depth.

5.7.4 Storm Drainage & Sewer Connections to Multiple Family, Commercial and Other Blocks

- a) Parking lots, driveways and/or other hard surfaced areas servicing multiple family, commercial and other blocks shall be drained by a properly designed internal drainage system (including catchbasins, manholes and pipe) which shall connect to the storm sewer system or other approved outfall.
- b) A manhole shall be required, located either on private property, 1.50 metres from property line to centre of rim or on the municipal main.

5.7.5 Velocity and Grade

Minimum velocity	0.75 m/sec
Maximum velocity	4.50 m/sec

Standard residential connections must have a minimum slope of 1%.

5.7.6 Location of Service Connections

Sanitary and storm sewer connections shall be located in accordance with the applicable Town Standard Drawing.

5.7.7 Materials for Storm Sewer Service Connections

- a) Storm sewer service connections may be constructed using any of the materials outlined in Section 5.6 except for polyethylene, which is not listed as an acceptable material under the Plumbing Code.
- b) In order to avoid cross connections, all pipe used for residential storm laterals shall be the colour white.

5.8 Construction

Construction of all storm sewers and service connections in the Town of Lincoln shall be in accordance with the current and appropriate Town Specifications and Standard Drawings.

Full time inspection by a qualified Consulting Engineer retained by the Developer is required for the construction of the new storm system.

Compaction Reports by a qualified Geotechnical Engineer shall be submitted for pipe bedding and trench backfill at frequencies acceptable to the Town.

All testing shall be conducted under the supervision of the Consulting Engineer in accordance with the Town requirements to the satisfaction of the Director of Public Works.

The storm sewers shall be videoed by closed circuit television and a copy of the video and inspection report (as per NASSCO PACP, LACP, MACP -Latest Version) to be forwarded to the Town prior to issuance of the Completion Certificate of Primary Services by the Director of Public Works.

5.9 Roof Leaders

Roof drain connections to storm laterals for single family residences, duplexes and new housing are prohibited. Instead, they should discharge at the front of the dwelling onto splash pads with flows directed away from the building foundation onto grass filter strips, where possible and towards the road. Above ground discharge to be contained on the property in a manner that is not likely to cause damage to any adjoining property or create hazardous conditions on any stairway, walkway, street or boulevard. **Under no circumstances will roof water leaders be permitted to be connected to the sanitary sewer system.**

5.10 Watercourse Alterations and Outfalls

- a) Where existing drainage courses are to be altered the requirements will be assessed by the Director of Public Works or designate on an individual basis. Also the Niagara Peninsula Conservation Authority has regulations applying to certain watercourses, which govern the construction in any area which may affect flooding, pollution or conservation of land. All alterations to existing watercourses must satisfy the requirements of both the Town and the Niagara Peninsula Conservation Authority.
- b) In general, all outfalls shall be designed to dissipate energy to a level that will not cause erosion of the receiving watercourse. Where structures are to be used, they shall be oriented in such a manner as to not impede flow in the receiving channel. As a minimum, rip rap as per Town Standard Drawings shall be placed at all sewer/culvert outlets.
- c) All watercourse alterations and/or outfall designs shall be supported by appropriate design calculations/analysis.

5.11 Erosion and Siltation Control

Drainage designs for all developments shall incorporate stormwater management techniques designed to minimize both site and downstream erosion, as well as minimize siltation and water quality impairment downstream. The developer will be responsible for meeting the requirements of the Ministry of Natural Resources, Ministry of the Environment, the Niagara Peninsula Conservation Authority and the Town of Lincoln.

5.12 Foundation Drains

Where connection of foundation drains to the storm sewer is required, connection should be made via a sump pump system in accordance with Town Standard Drawings. Direct connection of foundation drains to the storm system by gravity is not normally permitted.

5.13 Stormwater Facilities

- a) All permanent pool/"wet" ponds shall be enclosed with a 1.5m high chain link fence when abutting residential properties in accordance with DPW 702.
- b) Where a SWM pond is to be located adjacent to residences, a 3.0m wide "flat" area will be provided to serve as a groomed buffer area.
- c) SWM ponds are to be fully graded, groomed and planted within three months of excavation/construction.
- d) Underground storage tanks will only be considered in exceptional circumstances and must be supported by a thorough technical analysis to the satisfaction of the Director of Public Works or designate.
- e) The developer's engineer shall provide a report to the Town detailing maintenance recommendations based on the approved storm water management plan (i.e inspection of all structures and how frequently (min. once annually), removal of all sediments and how frequently, method of re-stabilizing of all disturbed areas, sediments to be tested to determine method of disposal, effluent sampling protocol, etc.).

6.0 Water Distribution Systems

6.1 Design Flows

- a) For design purposes the following population densities and water demand allowances shall be used:
 - a. Population Density Factors (Based on the Town’s Official Plan Unit Densities)
 - i. Single Family Units – 2.8 persons/unit
 - ii. Semi/Townhouse Units – 2.2 persons/unit
 - iii. High density Units (Apartment) – 1.7 persons/unit
 - iv. Mixed Used – 2.5 persons/unit
 - b. Water Demands
 - i. Commercial Demands
 - 1. 270 L/job/day; or
 - 2. 5 L/m²/day
 - ii. Residential Flow
 - 1. 240 L/cap/day
- b) Determination of demand design flows outside of the uses outlined above shall conform to the latest edition of the Ontario Ministry of the Environment's "Guidelines for the Design of Water Storage Facilities, Water Distribution Systems, Sanitary Sewage Systems and Storm Sewers".
- c) Fire flows shall be determined in accordance with the "Water Supply for Public Fire Protection Guidelines" by the Fire Underwriters Survey. However, for new systems or major upgrades, fire flow allowances should not be less than 80 litres/sec.

6.2 System Pressures & Structural Requirements

The maximum sustained operating pressures shall not exceed 700 kPa. Where pressures in localized areas are above this level, pressure-reducing valves shall be installed on the services.

The distribution system shall be sized to meet normal peak demands. Under conditions of simultaneous maximum day and fire flow demands, the pressure shall not drop below 140 kPa. Under normal operating conditions, the pressure shall not drop below 275 kPa.

Watermains shall be designed to withstand the maximum operating pressure plus the transient pressure to which it may be subjected. All watermains shall be capable of withstanding a minimum design pressure of 1035 kPa, regardless of the working pressure in the system or the rating necessary to meet the structural requirements of the trench condition.

6.3 Friction Factors

The following "C" values shall be used for the design of water distribution systems regardless of pipe materials:

Pipe Diameter (mm)	C - Factor
100 to 150	100
200 to 250	110

300 to 600	120
Over 600	130

The above “C” factors represent long term values. A “C” factor of 140 shall be used to calculate maximum velocities for transient pressure estimations, or for checking pump motor sizes for run out conditions.

6.4 Watermain Sizing and Layout

6.4.1 Sizes

Sizes and looping of watermains will be determined at the preliminary stage of the development. In areas where no master servicing scheme has been prepared, the consultant shall be required to undertake an analysis of the distribution system in order to determine an acceptable size of watermain. The following are the minimum size requirements.

Residential Areas - 150mm diameter minimum, 100mm diameter will be allowed on cul-de-sacs where a fire hydrant is available within 75 metres of the most remote dwelling unit.

Industrial Areas - 300mm diameter minimum for new industrial developments.

6.4.2 Depth of Cover

Generally the depth of cover shall not be less than 1.70 metres measured in a vertical plane above the pipe from the top of the pipe to the finished ground elevation. However, at no time should the minimum depth of cover to watermains be less than the depth of frost penetration.

It will be the responsibility of the consultant to justify any reduction in the depth of cover less than 1.70 metres by submitting a report outlining the reasons for the reduction and alternative frost protection measures to be taken.

Where polystyrene (Styrofoam SM) is proposed as insulation, it is required that a minimum of 50mm of thickness be provided for every 300mm of reduction in cover.

Where pre-insulated pipes are proposed, the manufacturer’s design and construction recommendations shall be adhered to.

6.4.3 Vertical Separation Between Watermains and Sewers

- a) Under normal conditions, watermains shall cross above sewers with sufficient vertical separation to allow for proper bedding and structural support of the watermain and sewer main.
- b) When it is not possible for the watermain to cross above the sewer, the watermain shall be protected by providing:
 - i) A vertical separation of at least 0.5m shall be provided between the invert of the sewer and the crown of the watermain.
 - ii) The sewers shall be adequately supported to prevent excessive deflection of joints and settings.
 - iii) The length of watermain shall be centred at the point of crossing so that the joints will be equidistant and as far as possible from the sewer.

Watermain crossings, adhere to the latest MOECC Design Guidelines.

6.4.4 Horizontal Separation Between Watermains and Sewers

Under normal conditions, watermains shall be laid with a horizontal separation of at least 2.50 metres from any sewer manhole. The distance shall be measured from the nearest edges.

6.4.5 Separation of Watermain and Sewers - Special Conditions

Under unusual conditions, where a significant portion of the construction will be in rock, where it is anticipated that severe dewatering problems will occur, or where congestion with other utilities will prevent a clear horizontal separation of 2.50 metres, a watermain may be laid closer to a sewer, provided that the elevation of the crown of the sewer is at least 0.50 metre below the invert of the watermain. Such separation shall be in-situ material or compacted backfill.

Where this vertical separation cannot be obtained, the sewer shall be constructed of materials and with joints that are equivalent to watermain standards of construction and shall be pressure tested to assure water tightness.

In rock trenches, facilities should be provided to permit drainage of the trench to minimize the effects of impounding of surface water and/or leakage from sewers in the trench.

6.4.6 Utility Crossings

Where watermains cross over or under utilities other than sewers, the clearance and type of crossing provided shall conform to the requirements of the particular utility involved and provide proper bedding and structural support of the watermain and utility.

6.4.7 Dead Ends

Wherever possible, the distribution system shall be designed to eliminate dead-end sections. Where dead-ends cannot be avoided, they shall be provided with a fire hydrant or flushing port to Town specifications. No service connections are permitted downstream of the terminal flushing point.

6.5 Line Valves

6.5.1 Type

Gate valves shall be used on all watermains 300mm diameter and under.

All valves shall be in accordance with AWWA C500, resilient seat, non-rising stem with stainless steel bolts and a 50mm square operating nut opening counter clockwise.

6.5.2 Sizes

The sizes of the line valves shall be the same size as the watermain.

6.5.3 Number, Location and Spacing

A minimum of three valves are required at a tee intersection and a minimum of four valves are required at a cross intersection. The valves shall be located at the point where the projections of the street line intersects the watermain. Valve boxes and chambers shall be located in boulevards whenever possible.

Line valves shall be located such that no more than 20 houses will be shut off at one time. In no case shall the spacing exceed 300 metres.

Maximum spacing of line valves on feeder mains shall be 750 metres.

6.5.4 Air Release Valves

Air release valves shall be placed at all significant high points of the distribution system. In addition, an attempt shall be made to locate hydrants at high points or at dead ends, thereby eliminating the need for vacuum-air relief valves and/or blow-offs.

6.5.5 Drain Valves

Drain valves shall be located at the low points of all water mains of 600mm diameter and greater.

6.5.6 Valve Boxes and Chambers

All valves 250mm diameter and smaller shall have valve boxes and specified direct bury operators shall be used.

All valves 400mm diameter and larger shall be installed in valve chambers with extension stems and valve box on the edge of the chamber as per Town Standard Drawings.

The tops of valve boxes and valve chamber manhole covers shall be set flush with finished grade. The top of the roof slab of valve chambers shall be at least 0.60 metre below the profile of the finished pavement. Valve boxes should be 125mm in diameter.

Chambers or pits containing valves, blow-offs, meters or other such appurtenances to a distribution system shall not be connected directly to any sanitary or combined sewer, nor shall blow-offs or air-relief valves be connected directly to any such sewer.

In order to minimize the total number of chambers on any project, care should be exercised in locating the line valves, air-reliefs, drains, etc., with a view to combining these functions in a single chamber.

6.5.7 Tapping Sleeve and Valve

Connection of a new water main and the existing water distribution system shall be made using a tee and sleeve. In the event that the water distribution system cannot be taken out of service a tapping valve and tapping sleeve shall be utilized, subject to approval by the Town (only stainless steel will be permitted).

6.6 Hydrants

- a) All hydrants installed on water mains shall have a 150mm diameter branch valve and box and will be self draining. "Steamer" port to have 100mm Storz connector. Hydrant installation shall be as per Town Standard Drawing.
- b) Hydrant branch valve will open in the same direction as the mainline water main valve and shall be a minimum of one metre away from the fire hydrant.

If the branch valve is positioned next to the water main, the branch valve must be attached to the anchor tee.

-
- c) Hydrants shall be installed on all watermains 150mm diameter and larger with the following maximum allowable spacing, measured along the fire vehicles path of travel to the principle entrance of the unit.
 - i) 150 metres in residential areas, or to provide for a maximum hose length of 75 metres;
 - ii) 75 metres in industrial and commercial areas to provide for a maximum hose length of 37.5 metres;
 - iii) 300 metres in rural areas.
 - d) The following criteria must be followed where applicable:
 - i) On the same side of the road as the watermain.
 - ii) Within the Town's road allowance at the extension of the lot line between two lots to avoid conflicts with driveways.
 - iii) If near a driveway, hydrant will be located a minimum of 1.2 metres clear from the driveway edge.
 - iv) For watermains up to, and including 300mm diameter, hydrants will be located at high and low points to function as manual air release and drain points.
 - v) One metre away from an underground utility or open ditch.
 - vi) A 3 metre minimum clearance around the hydrant from any above ground obstructions.
 - vii) In existing areas, hydrants should be at least 1.2 metres away from the back of curb, edge of pavement or roadway shoulder.
 - e) A 19mm protection conduit buried 150mm below grade to 150mm above grade to contain tracer wire as per Town Standard Drawings.
 - f) When replacing existing hydrants use the same location, if possible. If a hydrant is to be relocated to a new location. Notify the affected homeowners prior to installation.
 - g) Hydrants located adjacent to parking areas, vehicle traffic areas or in areas without curbing will be protected by bollards or guard posts. The bollard must be located so they are not directly in front of, or interfering with a nozzle cap. The posts should be of 150mm steel pipe positioned at least 1.2 metres from the hydrant, cemented into the ground vertically, buried at least 0.6 metres below grade and exposed by at least 0.9 metres above ground. The post to be filled with soil or concrete and capped with concrete. Upon cement curing, the posts will be painted with reflective safety yellow enamel for ease of visibility.

6.7 Thrust Restraint

- a) For thrust restraint, joint restraining devices by Uniflange Series 1300, 1350, 1360, 1390 or approved equal are to be used. Use of restrained joints must be supported by appropriate design calculations.
- b) Concrete thrust blocks will only be permitted where the likelihood of undermining by other utilities is minimal as determined by the Director of Public Works or designate. Where permitted, concrete thrust blocks shall be as per Town Standard Drawings. All concrete for thrust blocks shall be laid to undisturbed ground. Where soil conditions or working pressures exceed those values contained in the Town Standards, thrust blocking shall be individually designed.

6.8 Watermain Pipe Materials

- a) The following materials may be used for watermains:
 - i) Polyvinyl Chloride (PVC) can be used for sizes up to 600mm diameter, when installed under roadways. In other locations this limit may be extended to 900mm diameter upon approval of the Director of Public Works, or designate.

Bionax DR18 PVC or Bionax PVCO pipe either to be associated with CSA Standard B137.3.1. Restraints and torque rating as per manufacturers specifications.
 - ii) Reinforced Concrete Pressure Pipe (RCPP) can be used for sizes 400mm and greater.
 - iii) Cement Lined Ductile Iron Pipe (DI) may be used if enclosed in a chamber. Stainless steel wall sleeves to be used.
 - iv) Polyethylene Pipe (PE) may be used for sizes up to 600mm diameter, upon the approval of the Director of Public Works or designate.
- b) All pipe material and associated appurtenances must meet current American Water Works Association (AWWA) specifications and Ontario Provincial Standard Specifications (OPSS).

6.9 Tracer Wire

- a) Tracer wire shall be 10 gauge solid copper plastic coated tracer wire, T.W.U. 75 C600 V or approved equal.
- b) Tracer wire is to be secured to pipe at every fitting valve and at intervals not exceeding 3.0 metres by the use of fibreglass tape or plastic tie wrap.
- c) All connections to be waterproofed.
- d) Tracer wire to be installed at valve boxes as per Town Standard Drawing.
- e) Waterproof direct bury connectors for tracer wire, dielectric silicone filled. Non-locking friction fit, twist on or taped connectors are prohibited.
- f) The tracer wire system shall be tested for functionality by Town forces only after the Contractor has confirmed and demonstrated that the entire tracer wire system is installed and functioning properly.

6.10 Corrosion Protection

All metallic pipe, fittings, appurtenances, etc., installed underground must be protected using Denso Anti-Corrosion Protection System, meeting ISO 9001 Standards, consisting of primer, mastic and tape in accordance with manufacturers recommendations. Corrosion protection must not cover drain ring on fire hydrants.

Zinc Cathodic Protection to be installed where required.

6.11 Cathodic Protection of Watermain and Appurtenances

- a) For non-metallic watermain installation all metallic watermain fittings, hydrants, water services and restrainers are to have high grade zinc anodes installed of the sizes specified in the following table:

Pipe/Fitting Size (mm)	Zinc Anode Size (Kg)
100 and 150	2.7
200	5.5
250	5.5
300	5.5
400	11
450	11
Hydrant	11

Copper Service Size (mm)	Zinc Anode Size (Kg)
20	5.5
25	5.5
38	5.5
50	5.5

- b) For new ductile iron watermains, the required cathodic protection shall be designed specifically to suit the site conditions by an experienced corrosion specialist to the satisfaction of the Director of Public Works or designate.

6.12 Water Service Connection

6.12.1 General

In new developments, the service connections shall be installed in accordance with the Standard Drawings terminating at the property line.

No service connection shall be made to watermains greater than 400mm diameter.

6.12.2 Pipe Sizes

- a) The minimum size for service connections shall be 20mm diameter except when the length of the connection from the main to the building setback exceeds 30 metres, then the minimum size shall be 25mm diameter;
- b) Service connections for multiple family dwellings shall be sized to provide capacity equivalent to a 20m diameter connection to each dwelling unit;
- c) Service connections for blocks, commercial and industrial areas shall be sized according to the intended use;
- d) Notwithstanding the above, in the Beamsville Urban Service area, the minimum size water service permitted for a single family dwelling located at or above **130 metre geodetic shall be 25mm;**
- e) Service connections for greenhouse or other agricultural use are to be in accordance with Town standard drawings. The maximum size permitted is 25mm.

6.12.3 Location

Water service connections shall not be located under a driveway. The locations of water service connections shall suit the house style in accordance with Town Standard Drawings.

6.12.4 Depth

In no case shall the cover of the water service connection be less than 1.70 metres.

6.12.5 Mainstops

All domestic water service connections shall have mainstops installed with stainless steel service saddle with double stainless steel bolts and nuts. Mainstop installed at the watermain equal to the water service connection diameter and all connections to be compression fittings. Mainstops installed as per Town Standard Drawings.

6.12.6 Curb Stops and Boxes

All service connections shall have curb stop and box, stainless steel rod and stainless steel cotter pin. All connections to be compression fittings. Curb stops and boxes installed as per Town Standard Drawings.

6.12.7 Materials

Water service connection 50mm diameter or less shall be type "K" soft copper. Water service connections larger than 50mm diameter shall be in accordance with Section 6.8.

6.12.8 Meter Pit/Chamber

All water service connections greater than 60 meters in length shall be required to install a meter pit/chamber as per Town Standard Drawings. Length is measured along the alignment of the water service. The meter chamber must be located on private property within 3m of the property line. A radial distance of 1.5m in and around the meter chamber should be free of any major landscaping or objects for future maintenance work. In all cases, the meter and chamber installation should be off driveways or parking areas. Additional criteria for fire services are included in Section 6.16.

6.12.9 Re-use of Water Service Line

A municipal water service connection up to and including 25mm in diameter for the purposes of servicing a residential dwelling can be reused if all of the following criteria is met:

- a) An exploratory dig in the presence of a Town Operator to verify the service meets current Town standards and specifications;
- b) The water service connection must not be a double connection; and
- c) The water service connection must have properly functioning curb stops and valves and no record of isolated low pressure complaints from the property occupant.

6.13 Construction

Construction of all watermains and service connections in the Town of Lincoln shall be in accordance with the current Town Specifications and Standard Drawings.

Full time inspection by a qualified Consulting Engineer retained by the Developer, is required for the construction of the new water distribution system.

Compaction Reports by a qualified Geotechnical Engineer shall be submitted for pipe bedding and trench backfill at frequencies acceptable to the Town.

The new water distribution system shall be pressure tested, flushed, chlorinated and bacterial tested under the supervision of the Consulting Engineer in accordance with Town requirements to the satisfaction of the Director of Public Works.

6.14 Water Meters

Water meters must be installed in all buildings prior to occupancy. Water meters must be purchased from the Town. The Town requires 72 hours notice for installation of the remote reader and/or meter.

6.15 Water Booster Stations

In general, all booster pump installations shall have the following:

- a) automatic detection and shutdown for overloads, under-loads, overheating and rapid cycling;
- b) visual fault display;
- c) field adjustable automatic restart.

Booster Pumping Stations will only be considered in exceptional circumstances and the requirements for each proposed use will be assessed by the Director of Public Works or designate on an individual basis.

6.16 Fire Lines

In general, private fire lines may be allowed connection to the municipal system subject to the following criteria:

- a) Properties requesting fire lines must have frontage on the watermain to which they are requesting connection.
- b) Within the urban areas, fire lines will be allowed to new developments and redevelopments, including residential, commercial, institutional and industrial.
- c) Outside of identified urban areas fire lines will only be permitted to existing commercial, institutional or industrial operations or similar redevelopments.
- d) The maximum diameter of private fire line permitted is 150mm.
- e) The maximum length of fire line permitted shall be sixty (60) metres. For the purposes of this policy, "length" is measured from the limit of the municipal right of way.
- f) All firelines shall be metered with backflow. Water used for fire fighting purposes will not be charged.
- g) The requirement for a backflow prevention device shall apply in accordance with By-law 07-06, as amended.

-
- h) All fire lines must have a shut off valve at the property line. Any fire line over 100mm diameter that crosses a road must be valved at both the connection to the municipal main and at the property line.
 - i) All technical details, inspection and testing pertaining to the design, construction and commissioning of the fire line shall be to the satisfaction of the Director of Public Works and the Fire Chief.
 - j) In addition to the above, the proponent must obtain the necessary permit from the Public Works Department, which outlines additional restrictions on use, maintenance reporting requirements, fees, etc.

6.17 Greenhouse Services

Where greenhouses are permitted by Town policy, they will be constructed in accordance with Town Standard Drawings.

6.18 Sampling Station

The requirement and location for sampling stations in any development will be determined by the Director of Public Works and shall be constructed in accordance as per DPW 612.

a) Location

Sampling stations shall be installed in locations determined by the Town.

The curb stop shall be located 1.0m from the property line.

The location should permit unobstructed operator access and have adequate surface drainage to a legal and adequate outlet.

b) Materials

Sampling Station shall be a Test Tap Water Station. All Fittings and materials shall be lead free to meet NSF 61 Standard.

Typical install from watermain to Test Tap Sampling Station: ¾" domestic -> ¾" curb stop -> ¾" domestic pipe -> test tap.

Sampling station will be equipped with a 25mm FIP inlet for the connection to the watermain.

Test Tap shall be 1.2 meters above finished grade with a 1.8 meters bury (standard design).
Test Tap and curb stop to rest on a concrete slab. 30cm x 30cm x 5cm patio slab is acceptable.

6.19 Removal and Abandoning Watermains and Services

Existing Watermain

Plug ends of all abandoned watermains with concrete. Plug all tees and crosses where the abandoned main connects to a main remaining in service. Remove valve box and caps and bury valve. Remove hydrants for disposal or salvage for Town to reuse.

Existing Water Service

Water services which are being abandoned shall be detached at the main. If it is a tee, the tee is to be removed and a filler piece installed. If it is a tapping valve and valve is in good condition, valve can be shut off and service line disconnected at mainstop. Removal of curb box at property line.

7.0 Lot Grading and Service Drainage

7.1 General

Generally, it will be the responsibility of the developer to ensure that lot grading is completed to the satisfaction of the Town. Lot grading shall be in accordance with Town Standard Drawings provided for that purpose.

Any proposed deviation from this standard will require approval by the Public Works Director or designate.

7.2 Objectives

The lot grading plan should be designed with the following objectives in mind:

- a) The establishment of independent and adequate drainage for each lot. This can be provided by either rear to front drainage or split drainage intercepted in a rear yard swale.
- b) The establishment of lot and house grades which are compatible with existing topography and surrounding development. This will achieve maximum unity and protection for the property and enhance its appearance.
- c) The establishment of gradual gradation without terraces, steep slopes, or abrupt changes in grade. These are not only difficult to maintain, but also accentuate the artificiality of the new topography.

7.3 Design Criteria

The following criteria is intended for typical single and multi residential areas and is not applicable for Estate residential or areas of the municipality where more extreme topography may make portions of this criteria impractical.

- a) The maximum allowable difference in elevations between abutting lots along the rear lot line is 1 metre. The slope should be located on the lower property.
- b) Blend slopes shall not exceed 3H:1V.
- c) Storm runoff is to be self-contained within the subdivision limits and within the individual lots.
- d) The use of rear yard swales, embankments or retaining walls should be minimized.
- e) Grass surfaces shall have a minimum slope of 2%.
- f) Grading around houses and buildings shall direct the water away from the structure.
- g) Drainage flows, which are adjacent to houses, are to be in defined swales located as far from the house as possible.
- h) The desirable swale depth is 225mm with a minimum depth being 150mm. Maximum swale depth will vary depending on location and safety consideration (preferably not more than 500mm). See standard drawings for examples.

- i) Rear yard swales are to have a minimum slope of at least 1.0%, 2.0% desirable. Subdrain to be installed with less than 1.5% as per Town Standard Drawing.
- j) Where split drainage is used the maximum area allowed to drain between dwellings via the lower lot side swale shall be the area comprised of four quarter lots or 600m², whichever is less. Drainage from downspouts and sump pumps shall not be directed to the rear.
- k) Sod cannot be maintained on slopes greater than 3:1; therefore slopes steeper than 3:1 will not be permitted. If these cannot be met, steps or retaining walls will be required.
- l) All swales having a velocity in excess of 1.5 metres/second will be designed to incorporate erosion protection.
- m) The alignment of swales will not change more than 45 degrees. If this occurs, additional catch basins will be installed.
- n) The normal maximum runoff allowed in rear yard swales shall be the runoff from 6 backyards or 1800m², whichever is less. The length of rear yard swale shall not exceed 75m in length.
- o) When rear lot catchbasins are installed to pick up surface drainage, easements must be provided by the developer. The catchbasin and sewer should be located entirely on one lot.
- p) Major overland swales shall be located within easements based on the cross-section area of the channel required to carry the flow.
- q) The proposed elevations at the boundary of the subdivision shall match existing elevations.
- r) Provision is to be made to prevent ponding of water on lands bordering the subdivision and within the subdivision during construction.

7.4 Pre-grading

The existing topsoil shall be removed over the entire area of the subdivision lands, excluding park lands and stockpiled at locations approved by the Public Works Director or designate. The lands shall then be graded to the elevation shown on the Lot Grading Plan, making due allowance for final application of sod and topsoil and for placing material to be excavated from foundations and basements.

The pre-grading shall be completed to the satisfaction of the Public Works Director or designate.

7.5 Sodding and Tree Planting

The entire yard of all residential lots is to be sodded to the satisfaction of the Public Works Director or designate. Sodding will not be permitted in the months of July and August.

- a) Topsoil Specification: A minimum of 200 mm of unconsolidated native topsoil is to be placed over the entire lot where sod is to be placed and a lawn is to be established.
- b) A minimum of 750 mm of topsoil is to be placed on road boulevards where Town trees are planted.
- c) Native topsoil is to be screened through a 25 mm sieve to remove all large subsoil fragments stones, roots, and remnant construction material.

- d) Where imported topsoil is required, the same parameters shall be used to approve the source of the topsoil.
- e) Landscape areas located on an underground structure roof slab should maintain the following minimum topsoil depth of cover:
 - 900 mm for tree plantings
 - 600 mm for shrub plantings
 - 400 mm for sodded areas

Final Responsibility for Topsoil Quality:

The subdivision developer, as identified in the subdivision agreement, shall be wholly responsible for the placement of topsoil and sod and shall ensure that all lots are sodded and comply with the Town's topsoil policy and lot grading criteria until such time as the Town assumes the plan of subdivision/condominium.

7.6 Retaining Walls

- a) Any retaining walls within the Town are to be made from the following materials only:
 - i) Concrete;
 - ii) Pre-cast concrete block;
 - iii) Armour stone;
 - iv) Gabions.
 - v) Wood retaining walls will not be permitted.
- b) A private retaining wall is to be located entirely on the "high" lot, so that tie backs, if required, do not encroach onto adjacent properties.
- c) An stamped engineered detailed drawing showing location, cross section of the design will need to be submitted for approval. The retaining wall detail will show off-sets to lot lines, length, sufficient top of wall and footing elevations, wall material type, drainage ports, bedding and backfilling requirements.
- d) Retaining walls over 0.6m high require a railing.

7.7 Soakaway Pits/Infiltration Trenches

“Provision of adequate drainage and grading in accordance with Town standards is the responsibility of the proponent”. Soakaway systems will only be considered when attempts to provide all other alternatives for conveying runoff to a legal and adequate outlet have been exhausted by the proponent, to the satisfaction of the Town.

In any case, the approval of soakaway systems as the primary drainage outlet will be subject to the following:

- a) A soakaway system will only be considered for limited residential infill situations with a tributary area of 0.3 ha or less and up to 6 lots.
- b) The lot grading must be such that the volume resulting from a 100 year storm event can be stored without affecting any adjacent structures and does not exceed 0.3 metres in depth.
- c) Soakaway systems must be designed by a qualified Geotechnical Engineer. The design must be based upon actual field and/or laboratory testing of the on site soils.
- d) The design should have regard for the Ministry of Environment’s “Stormwater Management Planning and Design Manual”.
- e) The Geotechnical Engineer must confirm that the soakaway system will not impact on foundations and/or building envelopes of adjacent properties.
- f) The Geotechnical Engineer’s report shall also include a maintenance plan, where applicable for the system.
- g) The proponent will be required to enter into a Development Agreement with the Town governing the construction and maintenance of the soakaway system. The Development Agreement will be registered on title.

7.8 Mechanical Pump Systems

“Provision of adequate drainage and grading in accordance with Town standards is the responsibility of the proponent”. Soakaway systems will only be considered when attempts to provide all other alternatives for conveying runoff to a legal and adequate outlet have been exhausted by the proponent, to the satisfaction of the Town.

In any case, the approval of soakaway systems as the primary drainage outlet will be subject to the following:

- a) A soakaway system will only be considered for limited residential infill situations with a tributary area of 0.3 ha or less and up to 6 lots.
- b) The lot grading must be such that the volume resulting from a 100 year storm event can be stored without affecting any adjacent structures and does not exceed 0.3 metres in depth.
- c) Soakaway systems must be designed by a qualified Geotechnical Engineer. The design must be based upon actual field and/or laboratory testing of the on site soils.

- d) The design should have regard for the Ministry of Environment's "Stormwater Management Planning and Design Manual".
- e) The Geotechnical Engineer must confirm that the soakaway system will not impact on foundations and/or building envelopes of adjacent properties.
- f) The Geotechnical Engineer's report shall also include a maintenance plan, where applicable for the system.
- g) The proponent will be required to enter into a Development Agreement with the Town governing the construction and maintenance of the soakaway system. The Development Agreement will be registered on title.

In any case, development reliant on mechanical systems (i.e. pumps) for drainage will not be permitted.

PART 2:

Municipal Design Standards - Forms

S. C. S. TYPE II 6 HOUR RAINFALL DISTRIBUTION

TIME (hours)	RAINFALL AMOUNTS(mm)-RETURN PERIOD(years)						RAINFALL INTENSITY(mm/hr)-RETURN PERIOD(years)					
	2	5	10	25	50	100	2	5	10	25	50	100
TOTALS :	36.60	49.20	57.00	67.20	75.00	82.20						
0.00	.26	.34	.40	.47	.53	.58	1.28	1.72	2.00	2.35	2.63	2.88
.20	.26	.34	.40	.47	.53	.58	1.28	1.72	2.00	2.35	2.63	2.88
.40	.26	.34	.40	.47	.53	.58	1.28	1.72	2.00	2.35	2.63	2.88
.60	.26	.34	.40	.47	.53	.58	1.28	1.72	2.00	2.35	2.63	2.88
.80	.26	.34	.40	.47	.53	.58	1.28	1.72	2.00	2.35	2.63	2.88
1.00	.59	.79	.91	1.08	1.20	1.32	2.93	3.94	4.56	5.38	6.00	6.58
.20	.59	.79	.91	1.08	1.20	1.32	2.93	3.94	4.56	5.38	6.00	6.58
.40	.59	.79	.91	1.08	1.20	1.32	2.93	3.94	4.56	5.38	6.00	6.58
.60	.59	.79	.91	1.08	1.20	1.32	2.93	3.94	4.56	5.38	6.00	6.58
.80	.59	.79	.91	1.08	1.20	1.32	2.93	3.94	4.56	5.38	6.00	6.58
2.00	.84	1.13	1.31	1.55	1.73	1.89	4.21	5.66	6.56	7.73	8.63	9.45
.20	1.17	1.57	1.82	2.15	2.40	2.63	5.86	7.87	9.12	10.75	12.00	13.15
.40	2.78	3.74	4.33	5.11	5.70	6.25	13.91	18.70	21.66	25.54	28.50	31.24
.60	6.73	9.05	10.49	12.36	13.80	15.12	33.67	45.26	52.44	61.82	69.00	75.62
.80	10.98	14.76	17.10	20.16	22.50	24.66	54.90	73.80	85.50	100.80	112.50	123.30
3.00	2.16	2.90	3.36	3.96	4.43	4.85	10.80	14.51	16.82	19.82	22.13	24.25
.20	1.39	1.87	2.17	2.55	2.85	3.12	6.95	9.35	10.83	12.77	14.25	15.62
.40	1.06	1.43	1.65	1.95	2.18	2.38	5.31	7.13	8.27	9.74	10.88	11.92
.60	.88	1.18	1.37	1.61	1.80	1.97	4.39	5.90	6.84	8.06	9.00	9.86
.80	.73	.98	1.14	1.34	1.50	1.64	3.66	4.92	5.70	6.72	7.50	8.22
4.00	.48	.64	.74	.87	.98	1.07	2.38	3.20	3.71	4.37	4.88	5.34
.20	.48	.64	.74	.87	.98	1.07	2.38	3.20	3.71	4.37	4.88	5.34
.40	.48	.64	.74	.87	.98	1.07	2.38	3.20	3.71	4.37	4.88	5.34
.60	.48	.64	.74	.87	.98	1.07	2.38	3.20	3.71	4.37	4.88	5.34
.80	.48	.64	.74	.87	.98	1.07	2.38	3.20	3.71	4.37	4.88	5.34
5.00	.26	.34	.40	.47	.53	.58	1.28	1.72	2.00	2.35	2.63	2.88
.20	.26	.34	.40	.47	.53	.58	1.28	1.72	2.00	2.35	2.63	2.88
.40	.26	.34	.40	.47	.53	.58	1.28	1.72	2.00	2.35	2.63	2.88
.60	.26	.34	.40	.47	.53	.58	1.28	1.72	2.00	2.35	2.63	2.88
.80	.26	.34	.40	.47	.53	.58	1.28	1.72	2.00	2.35	2.63	2.88

RAINFALL HYETOGRAPH (CHICAGO METHOD)

\Town of Lincoln - 100 Year Design Storm

```

*****
*
* BEFORE PEAK * AFTER PEAK * DESIGN STORM *
*
*****
* TIME INTENSITY * TIME INTENSITY * TIME INTENSITY * RAINFALL(mm) *
* (MIN) (mm/HR) * (MIN) (mm/HR) * (HR) (mm/HR) INCR ACCUM *
*
*****
* 84.0 4.194 * * .2000 * 4.234 .85 .85 *
* 72.0 4.920 * * .4000 * 4.976 1.00 1.84 *
* 60.0 5.961 * * .6000 * 6.048 1.21 3.05 *
* 48.0 7.576 * * .8000 * 7.729 1.55 4.60 *
* 36.0 10.395 * * 1.0000 * 10.717 2.14 6.74 *
* 24.0 16.399 * * 1.2000 * 17.347 3.47 10.21 *
* 12.0 35.699 * * 1.4000 * 42.010 8.40 18.61 *
* 0 329.660 * * 1.6000 * 156.871 31.37 49.99 *
* * 12.0 44.312 * 1.8000 * 45.685 9.14 59.12 *
* * 24.0 20.587 * 2.0000 * 20.515 4.10 63.23 *
* * 36.0 13.012 * 2.2000 * 12.915 2.58 65.81 *
* * 48.0 9.439 * 2.4000 * 9.368 1.87 67.68 *
* * 60.0 7.393 * 2.6000 * 7.342 1.47 69.15 *
* * 72.0 6.078 * 2.8000 * 6.041 1.21 70.36 *
* * 84.0 5.165 * 3.0000 * 5.136 1.03 71.39 *
* * 96.0 4.495 * 3.2000 * 4.472 .89 72.28 *
* * 108.0 3.983 * 3.4000 * 3.965 .79 73.07 *
*
*****

```

```

*****
NOTE : DESIGN STORM VECTORS BASED ON INTEGRATION OF RAINFALL HYETOGRAPH
FOR EACH TIME INTERVAL
A = 2138.0000
B = 9.0000
C = .8580
R = .4500
0 TOTAL RAIN = AREA UNDER DISCRETIZED HYETOGRAPH = 73.07mm
TOTAL RAIN = INTENSITY (INTENSITY-DURATION CURVE) * DURATION = 73.07mm
1

```

1

RAINFALL HYETOGRAPH (CHICAGO METHOD)

\Town of Lincoln - 50 Year Design Storm

```
*****
*
* BEFORE PEAK * AFTER PEAK * DESIGN STORM *
*
*****
* TIME INTENSITY * TIME INTENSITY * TIME INTENSITY * RAINFALL(mm) *
* (MIN) (mm/HR) * (MIN) (mm/HR) * (HR) (mm/HR) INCR ACCUM *
*
*****
* 84.0 3.906 * * .2000 * 3.943 .79 .79 *
* 72.0 4.579 * * .4000 * 4.631 .93 1.71 *
* 60.0 5.542 * * .6000 * 5.624 1.12 2.84 *
* 48.0 7.036 * * .8000 * 7.178 1.44 4.28 *
* 36.0 9.641 * * 1.0000 * 9.938 1.99 6.26 *
* 24.0 15.177 * * 1.2000 * 16.049 3.21 9.47 *
* 12.0 12.927 * * 1.4000 * 18.716 7.74 17.22 *
* 0 302.032 * 0 302.032 * 1.6000 * 143.936 28.79 46.00 *
* * 12.0 40.836 * 1.8000 * 42.090 8.42 54.42 *
* * 24.0 19.031 * 2.0000 * 18.966 3.79 58.21 *
* * 36.0 12.055 * 2.2000 * 11.966 2.39 60.61 *
* * 48.0 8.758 * 2.4000 * 8.692 1.74 62.35 *
* * 60.0 6.868 * 2.6000 * 6.821 1.36 63.71 *
* * 72.0 5.651 * 2.8000 * 5.616 1.12 64.83 *
* * 84.0 4.806 * 3.0000 * 4.779 .96 65.79 *
* * 96.0 4.185 * 3.2000 * 4.164 .83 66.62 *
* * 108.0 3.710 * 3.4000 * 3.693 .74 67.36 *
*****
```

NOTE : DESIGN STORM VECTORS BASED ON INTEGRATION OF RAINFALL HYETOGRAPH
FOR EACH TIME INTERVAL
A = 1949.8000
B = 9.0000
C = .8560
R = .4500
0 TOTAL RAIN = AREA UNDER DISCRETIZED HYETOGRAPH = 67.36mm
TOTAL RAIN = INTENSITY (INTENSITY-DURATION CURVE) * DURATION = 67.36mm

1

RAINFALL HYETOGRAPH (CHICAGO METHOD)

Town of Lincoln - 25 Year Design Storm

```
*****
*
* BEFORE PEAK * AFTER PEAK * DESIGN STORM *
*
*****
*
* TIME INTENSITY * TIME INTENSITY * TIME INTENSITY * RAINFALL(mm) *
* (MIN) (mm/HR) * (MIN) (mm/HR) * (HR) (mm/HR) INCR ACCUM *
*
*****
*
* 84.0 3.640 * * .2000 * 3.672 .73 .73 *
*
* 72.0 4.240 * * .4000 * 4.286 .86 1.59 *
*
* 60.0 5.093 * * .6000 * 5.164 1.03 2.62 *
*
* 48.0 6.404 * * .8000 * 6.527 1.31 3.93 *
*
* 36.0 8.666 * * 1.0000 * 8.922 1.78 5.71 *
*
* 24.0 13.425 * * 1.2000 * 14.168 2.83 8.55 *
*
* 12.0 28.597 * * 1.4000 * 33.625 6.72 15.27 *
*
* 0 285.516 * 0 285.516 * 1.6000 * 129.338 25.87 41.14 *
*
* * 12.0 35.392 * 1.8000 * 36.528 7.31 48.45 *
*
* * 24.0 16.721 * 2.0000 * 16.663 3.33 51.78 *
*
* * 36.0 10.748 * 2.2000 * 10.669 2.13 53.91 *
*
* * 48.0 7.902 * 2.4000 * 7.845 1.57 55.48 *
*
* * 60.0 6.257 * 2.6000 * 6.215 1.24 56.72 *
*
* * 72.0 5.189 * 2.8000 * 5.158 1.03 57.76 *
*
* * 84.0 4.441 * 3.0000 * 4.418 .88 58.64 *
*
* * 96.0 3.889 * 3.2000 * 3.870 .77 59.41 *
*
* * 108.0 3.464 * 3.4000 * 3.449 .69 60.10 *
*
*****
```

NOTE : DESIGN STORM VECTORS BASED ON INTEGRATION OF RAINFALL HYETOGRAPH
FOR EACH TIME INTERVAL
A = 1616.2000
B = 8.0000
C = .8430
R = .4500
TOTAL RAIN = AREA UNDER DISCRETIZED HYETOGRAPH = 60.10mm
TOTAL RAIN = INTENSITY (INTENSITY-DURATION CURVE) * DURATION = 60.10mm

1

RAINFALL HYETOGRAPH (CHICAGO METHOD)

\Town of Lincoln - 10 Year Design Storm

```

*****
*           *           *           *           *           *
* BEFORE PEAK * AFTER PEAK *           DESIGN STORM *
*           *           *           *           *
*****
* TIME INTENSITY * TIME INTENSITY * TIME INTENSITY * RAINFALL(mm) *
* (MIN) (mm/HR) * (MIN) (mm/HR) * (HR) (mm/HR) INCR ACCUM *
*           *           *           *           *
*****
*           *           *           *           *           *
* 84.0 3.133 *           * .2000 * 3.161 .63 .63 *
*           *           *           *           *           *
* 72.0 3.646 *           * .4000 * 3.685 .74 1.37 *
*           *           *           *           *           *
* 60.0 4.374 *           * .6000 * 4.435 .89 2.26 *
*           *           *           *           *           *
* 48.0 5.492 *           * .8000 * 5.597 1.12 3.38 *
*           *           *           *           *           *
* 36.0 7.417 *           * 1.0000 * 7.634 1.53 4.90 *
*           *           *           *           *           *
* 24.0 11.455 *           * 1.2000 * 12.085 2.42 7.32 *
*           *           *           *           *           *
* 12.0 24.283 *           * 1.4000 * 28.516 5.70 13.02 *
*           *           *           *           *           *
* 0 239.892 * 0 239.892 * 1.6000 * 108.930 21.79 34.81 *
*           *           *           *           *           *
*           * 12.0 30.014 * 1.8000 * 30.965 6.19 41.00 *
*           *           *           *           *           *
*           * 24.0 14.247 * 2.0000 * 14.197 2.84 43.84 *
*           *           *           *           *           *
*           * 36.0 9.185 * 2.2000 * 9.118 1.82 45.66 *
*           *           *           *           *           *
*           * 48.0 6.767 * 2.4000 * 6.718 1.34 47.01 *
*           *           *           *           *           *
*           * 60.0 5.367 * 2.6000 * 5.331 1.07 48.07 *
*           *           *           *           *           *
*           * 72.0 4.456 * 2.8000 * 4.430 .89 48.96 *
*           *           *           *           *           *
*           * 84.0 3.818 * 3.0000 * 3.798 .76 49.72 *
*           *           *           *           *           *
*           * 96.0 3.346 * 3.2000 * 3.330 .67 50.39 *
*           *           *           *           *           *
*           * 108.0 2.982 * 3.4000 * 2.969 .59 50.98 *
*           *           *           *           *           *
*****

```

NOTE : DESIGN STORM VECTORS BASED ON INTEGRATION OF RAINFALL HYETOGRAPH
FOR EACH TIME INTERVAL
A = 1349.0000
B = 8.0000
C = .8400
R = .4500
TOTAL RAIN = AREA UNDER DISCRETIZED HYETOGRAPH = 50.98mm
TOTAL RAIN = INTENSITY (INTENSITY-DURATION CURVE) * DURATION = 50.98mm

1

1

RAINFALL HYETOGRAPH (CHICAGO METHOD)

\Town of Lincoln - 5 Year Design Storm

```
*****
*
* BEFORE PEAK * AFTER PEAK * DESIGN STORM *
*
*****
*
* TIME INTENSITY * TIME INTENSITY * TIME INTENSITY * RAINFALL (mm) *
* (MIN) (mm/HR) * (MIN) (mm/HR) * (HR) (mm/HR) INCR ACCUM *
*
*****
*
* 84.0 2.874 * * .2000 * 2.898 .58 .58 *
*
* 72.0 3.319 * * .4000 * 3.353 .67 1.25 *
*
* 60.0 3.946 * * .6000 * 3.998 .80 2.05 *
*
* 48.0 4.897 * * .8000 * 4.985 1.00 3.05 *
*
* 36.0 6.511 * * 1.0000 * 6.689 1.34 4.38 *
*
* 24.0 9.840 * * 1.2000 * 10.351 2.07 6.45 *
*
* 12.0 20.257 * * 1.4000 * 21.713 4.74 11.20 *
*
* 0 215.695 * 0 215.695 * 1.6000 * 92.649 18.51 29.73 *
*
* * 12.0 24.905 * 1.8000 * 25.703 5.14 34.87 *
*
* * 24.0 12.119 * 2.0000 * 12.074 2.41 37.28 *
*
* * 16.0 7.975 * 2.2000 * 7.918 1.58 38.87 *
*
* * 48.0 5.969 * 2.4000 * 5.927 1.19 40.05 *
*
* * 60.0 4.791 * 2.6000 * 4.760 .95 41.00 *
*
* * 72.0 4.016 * 2.8000 * 3.994 .80 41.80 *
*
* * 84.0 3.468 * 3.0000 * 3.451 .69 42.49 *
*
* * 96.0 3.059 * 3.2000 * 3.045 .61 43.10 *
*
* * 108.0 2.742 * 3.4000 * 2.711 .55 43.65 *
*
*****
```

NOTE : DESIGN STORM VECTORS BASED ON INTEGRATION OF RAINFALL HYETOGRAPH
 FOR EACH TIME INTERVAL
 A = 1039.2000
 B = 7.0000
 C = .8210
 R = .4500
 0 TOTAL RAIN = AREA UNDER DISCRETIZED HYETOGRAPH = 43.65mm
 TOTAL RAIN = INTENSITY (INTENSITY-DURATION CURVE) * DURATION = 43.65mm

1

1

RAINFALL HYETOGRAPH (CHICAGO METHOD)

\Town of Lincoln - 2 Year Design Storm

Table with columns: BEFORE PEAK, AFTER PEAK, DESIGN STORM, TIME INTENSITY (MIN) (mm/HR), TIME (HR), INTENSITY (mm/HR), RAINFALL (mm) INCR, ACCUM. Rows show data points from 84.0 to 108.0 minutes.

NOTE : DESIGN STORM VECTORS BASED ON INTEGRATION OF RAINFALL HYETOGRAPH FOR EACH TIME INTERVAL

- A = 692.6000
B = 6.0000
C = .8020
R = .4500

TOTAL RAIN = AREA UNDER DISCRETIZED HYETOGRAPH = 32.33mm
TOTAL RAIN = INTENSITY (INTENSITY-DURATION CURVE) * DURATION = 32.33mm

1

PART 3:

Municipal Design Standards - Drawings

TABLE OF CONTENTS**PART 3: Municipal Design Standards - Drawings****Series 200 - Grading**

DPW-200	Subdivision Lot Grading, Two Way Drainage
DPW-201	Subdivision Lot Grading, One Way Drainage
DPW-202	Industrial, Commercial and Institutional Grading and Servicing Plan
DPW-203	Rural Commercial and Industrial Grading and Servicing Plan
DPW-204	Rear Yard Swale Subdrain Installation

Series 300 - Entrances and Sidewalk Construction

DPW-300	Standard Entrances - Low Volume Access
DPW-301	Standard Entrances - High Volume Access
DPW-302	Urban Residential Entrance
DPW-303	Rural Entrance to Road with Culvert Installation
DPW-304	Standard Walkway
DPW-305	Standard Footpath
DPW-306	Standard Sidewalk Detail
OPSD 310.010	Concrete Sidewalk
OPSD 310.020	Concrete Sidewalk Adjacent to Curb and Gutter
OPSD 310.030	Concrete Sidewalk Ramps at Intersections
OPSD 310.040	Utility Isolation in Sidewalks

Series 400 - Roadways, Curbs and Gutters

DPW-400	Urban Local Road Section and Utility Installations
DPW-401	Rural Road Section and Utility Installations
DPW-402	Minor Collector or Industrial Road
DPW-403	Turning Basin for Terminated Urban Roadways
DPW-404	Turning Basin for Terminated Rural Roadways
DPW-405	Road 'Elbow' Design
DPW-406	Service Installation in the Roadway Area (Open Cut Method)
DPW-407	Curb and Gutter Subdrain
OPSD 600.040	Concrete Barrier Curb with Standard Gutter for Flexible Pavement
OPSD 600.070	Concrete Barrier Curb with Standard Gutter Two Stage Construction

Series 500 - Sanitary and Storm Sewers

DPW-500	Trench Bedding and Embedment for Pipes
DPW-501	Sewer Lateral Connections
DPW-502	Site Servicing Alternatives
DPW-503	Standard Sewer Lateral Installations
DPW-504	Sump Pump Lateral Installations
DPW-505	Sanitary Clean-Out (Landscaped Areas)
DPW-506	Sanitary Clean-Out (Hard Surface Areas)
DPW-507	Precast Rearyard Catchbasin Without Sump
DPW-508	Sanitary Backwater Valve Installation Detail Residential Lateral
OPSD 401.010	Cast Iron, Square Frame with Circular Closed or Open Cover for Maintenance Holes
OPSD 403.010	Galvanized Steel Honey Comb Grating for Ditch Inlet
OPSD 404.020	Aluminum Safety Platform for Circular Maintenance Hole
OPSD 405.020	Maintenance Hole Steps - Solid
OPSD 701.010	Precast Concrete Maintenance Hole 1200mm Diameter
OPSD 701.011	Precast Concrete Maintenance Hole 1500mm Diameter
OPSD 701.012	Precast Concrete Maintenance Hole 1800mm Diameter
OPSD 701.013	Precast Concrete Maintenance Hole 2400mm Diameter
OPSD 701.021	Maintenance Hole Benching and Pipe Opening Details
OPSD 705.010	Precast Concrete Catch Basin 600mm x 600mm
OPSD 705.030	Precast Concrete Ditch Inlet 600mm x 600mm
OPSD 1003.010	Cast-in-Place Maintenance Hole Drop Structure - Tee
OPSD 1003.020	Cast-in-Place Maintenance Hole Drop Structure - Wye

Series 600 - Watermains

DPW-600	Hydrant Installation
DPW-601	50mm Blow Off Installation
DPW-602	Standard Water Service Installation Detail for 20mm and 25mm Diameter Sizes
DPW-603	Standard Water Service Installation Detail for 38mm and 50mm Diameter Sizes
DPW-604	25mm Flowmeter in Chamber
DPW-605	6-8" Flowmeter in Chamber Plan (2 Pages)

DPW-606	Greenhouse Water Service Installation Schematic
DPW-607	Water Service Installation – Commercial/Industrial
DPW-608	Residential Water Meter (25mm Diameter and Under)
DPW-609	Temporary Connection for Pipes 100mm Diameter or Larger
DPW-610	Temporary Flushing/Testing Connection
DPW-611	Typical Install from Watermain to Test Tap Sampling Station
OPSD 1101.010	Precast Valve Chamber 1200mm and 1500mm Diameter
OPSD 1101.011	Piping Layout for Butterfly and Gate Valves 350mm Diameter and Smaller in Circular Precast Chamber
OPSD 1103.010	Concrete Thrust Blocks for Tees, Plugs and Horizontal Bends
OPSD 1103.020	Concrete Thrust Block for Vertical Bends
OPSD 1108.010	Cast-in-Place Water Meter Chamber for 75mm to 250mm Meters

Series 700 - Miscellaneous

DPW-700	Dead End Barricade
DPW-701	Standard Board on Board Fence Detail
DPW-702	Standard Chain Link Fence Detail
DPW-703	Lighting Assembly Conventional Installation
DPW-703A	Lighting Assembly Conventional Equipment List
DPW-704	Lighting Assembly Decorative Installation
DPW-704A	Lighting Assembly Decorative Equipment List
DPW-705	Duct Termination at Embedded Concrete Poles
DPW-706	Light Assembly Decorative (Type 3) Installation
DPW-706A	Light Assembly Decorative (Type 3) Equipment List
DPW-707	Warning & Regulatory Signs and Street Name Sign Installation
DPW-708	Deciduous Tree Planting 40mm, 50mm, 60mm Caliper
DPW-709	Tree Protection Fencing
DPW-710	Typical Prefabricated Trench Protection Arrangement
DPW-711	Standard Bench

- DPW-712 Typical Noise Wall Layout**
- DPW-713 Typical Utility Support**
- DPW-714 Tourist Directional Sign Installation**
- DPW-715 Rural Mail Box**
- DPW-716 Asphalt Speed Hump (8.5m Urban Local Road)**
- DPW-717 Asphalt Speed Cushions (8.5m Urban Collector Road)**



TOWN OF LINCOLN STANDARD DRAWINGS

Index

SERIES 200 – GRADING

<u>DRAWING NO.</u>	<u>TITLE</u>
D.P.W. – 200	SUBDIVISION LOT GRADING, TWO WAY DRAINAGE
D.P.W. – 201	SUBDIVISION LOT GRADING, ONE WAY DRAINAGE
D.P.W. – 202	INDUSTRIAL, COMMERCIAL AND INSTITUTIONAL GRADING AND SERVICING PLAN
D.P.W. – 203	RURAL INDUSTRIAL AND COMMERCIAL GRADING AND SERVICING PLAN
D.P.W. – 204	REAR YARD SWALE SUBDRAIN DETAIL

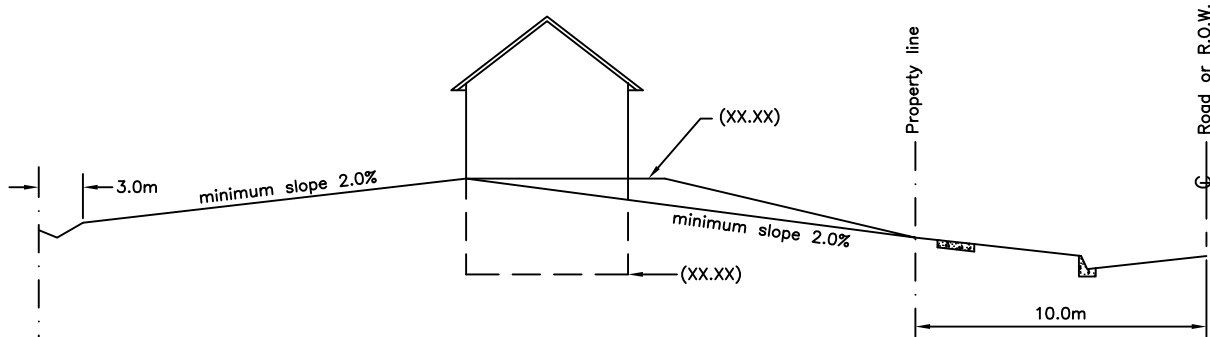

TYPICAL SECTION

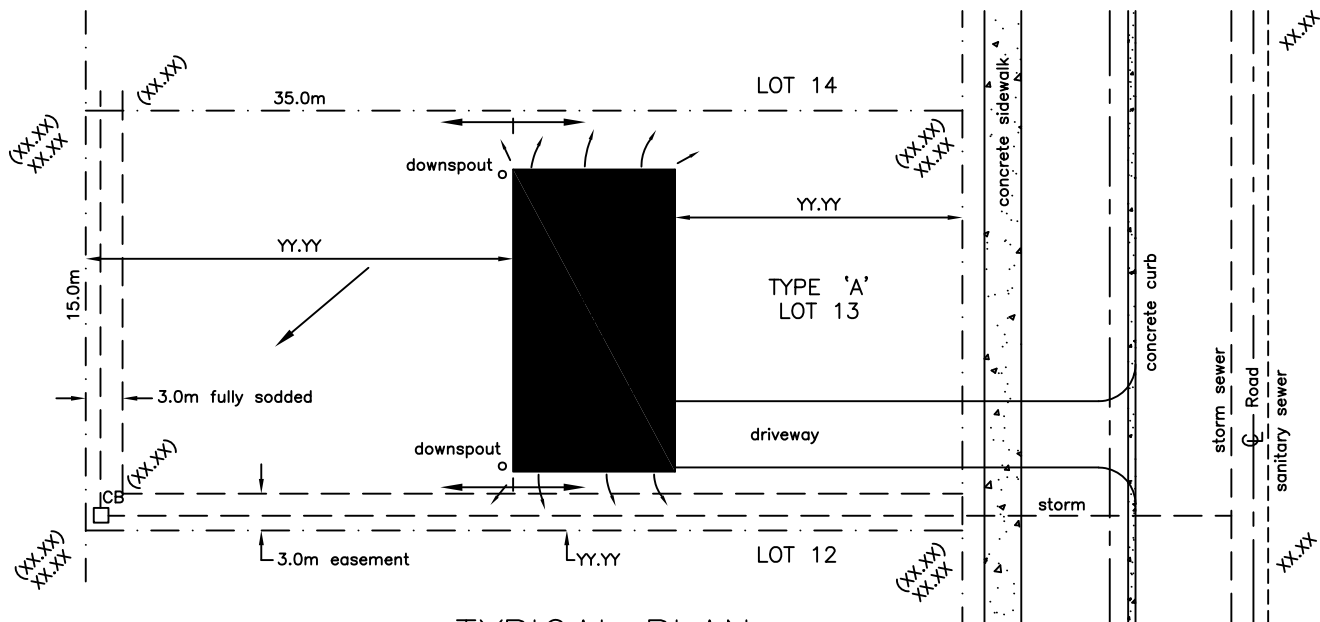

TYPICAL PLAN

NOTES:

1. House elevation denotes elevation of ground at house.
2. House elevation for a lot with two-way drainage shall be a minimum 375mm above the road centreline.
3. Minimum slope shall be 2.0%.
4. The normal maximum runoff allowed in rear yard swales shall be the runoff from 6 backyards or 1800m², whichever is less. Rear yard swales should not exceed 75m in length or 0.5m in depth.
5. Top of rear catchbasins shall be 75mm below ground level.
6. Geodetic bench mark shall be shown.
7. Maximum driveway slope shall be 7.0%.
8. Proposed swale elevations shall be shown.
9. Applicable sideyard, rear yard, and front yard setbacks are to be shown.
10. All blend slopes shall be as follows:

	<u>HEIGHT</u>	<u>SLOPE</u>
SIDE:	0 - 0.6m	2:1 max.
REAR:	0 - 1.0m	3:1 max.
11. For lots not covered under subdivider's agreement, it will be necessary to indicate:
 - a) water courses, trees, fences, etc. on existing lot.
 - b) sufficient ground elevations on existing and adjacent lots to indicate direction of flow.

LEGEND

- (XX.XX) Proposed elevation
- XX.XX Existing elevation
- YY.YY House setbacks
- Flow direction

**SUBDIVISION LOT GRADING
TWO WAY DRAINAGE**



**TOWN of LINCOLN
STANDARD DRAWING**

DPW - 200

Rev. No.: 2 | Date: May 1999

Scale: N.T.S.

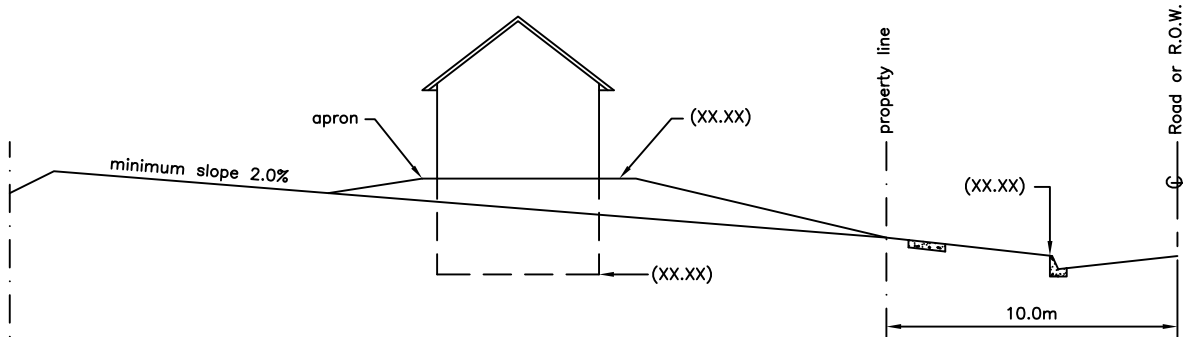

TYPICAL SECTION

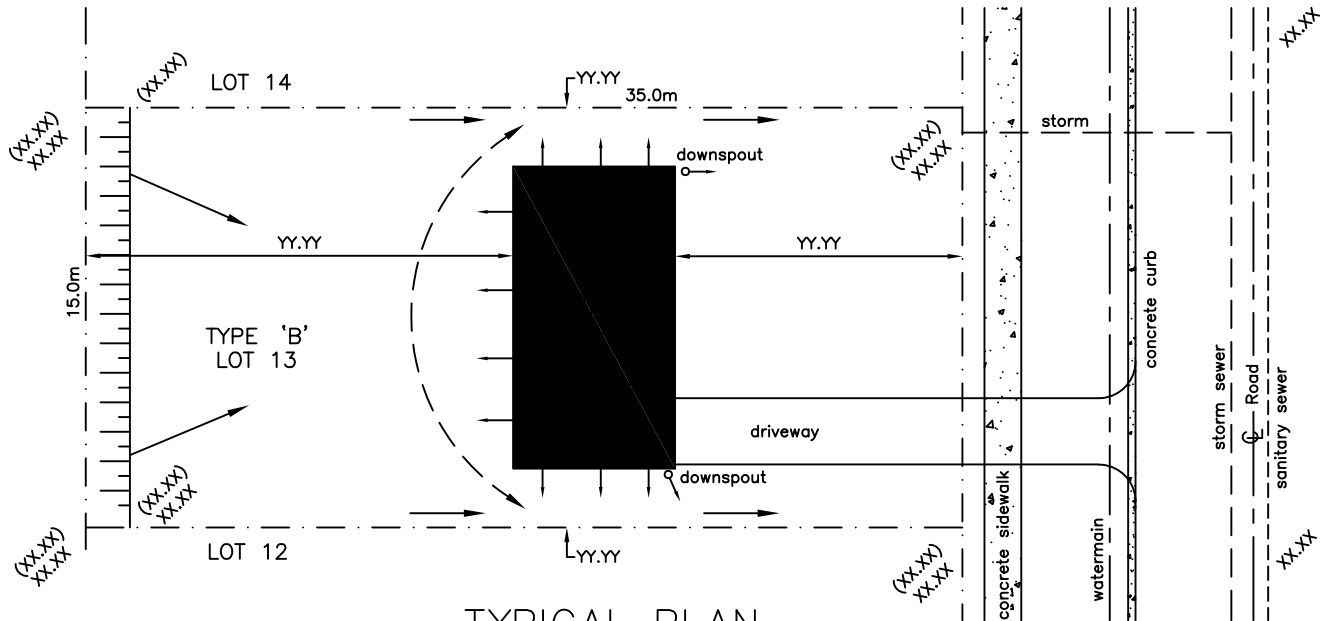

TYPICAL PLAN

NOTES:

1. House elevation denotes elevation of ground at house.
2. House elevation to be set minimum 300mm above the high front lot corner.
3. Minimum slope shall be 2.0%.
4. Geodetic bench mark shall be shown.
5. Height of apron around house shall be minimum 150mm above any swale.
6. Maximum driveway slope shall be 7.0%.
7. Applicable sideyard, back yard, and front yard setbacks are to be shown.
8. All blend slopes shall be as follows:

	<u>HEIGHT</u>	<u>SLOPE</u>
SIDE:	0 - 0.6m	2:1 max.
REAR:	0 - 1.0m	3:1 max.
9. For lots not covered under subdivider's agreement, it will be necessary to indicate:
 - a) water courses, trees, fences, etc. on existing lot.
 - b) sufficient ground elevations on existing and adjacent lots to indicate direction of flow.

LEGEND

- (XX.XX) Proposed elevation
- XX.XX Existing elevation
- YY.YY House setbacks
- Flow direction
- ▬ Top of fill

**SUBDIVISION LOT GRADING
ONE WAY DRAINAGE**



TOWN of LINCOLN
STANDARD DRAWING

DPW - 201

Rev. No.: 2 Date: May 1999

Scale: N.T.S.

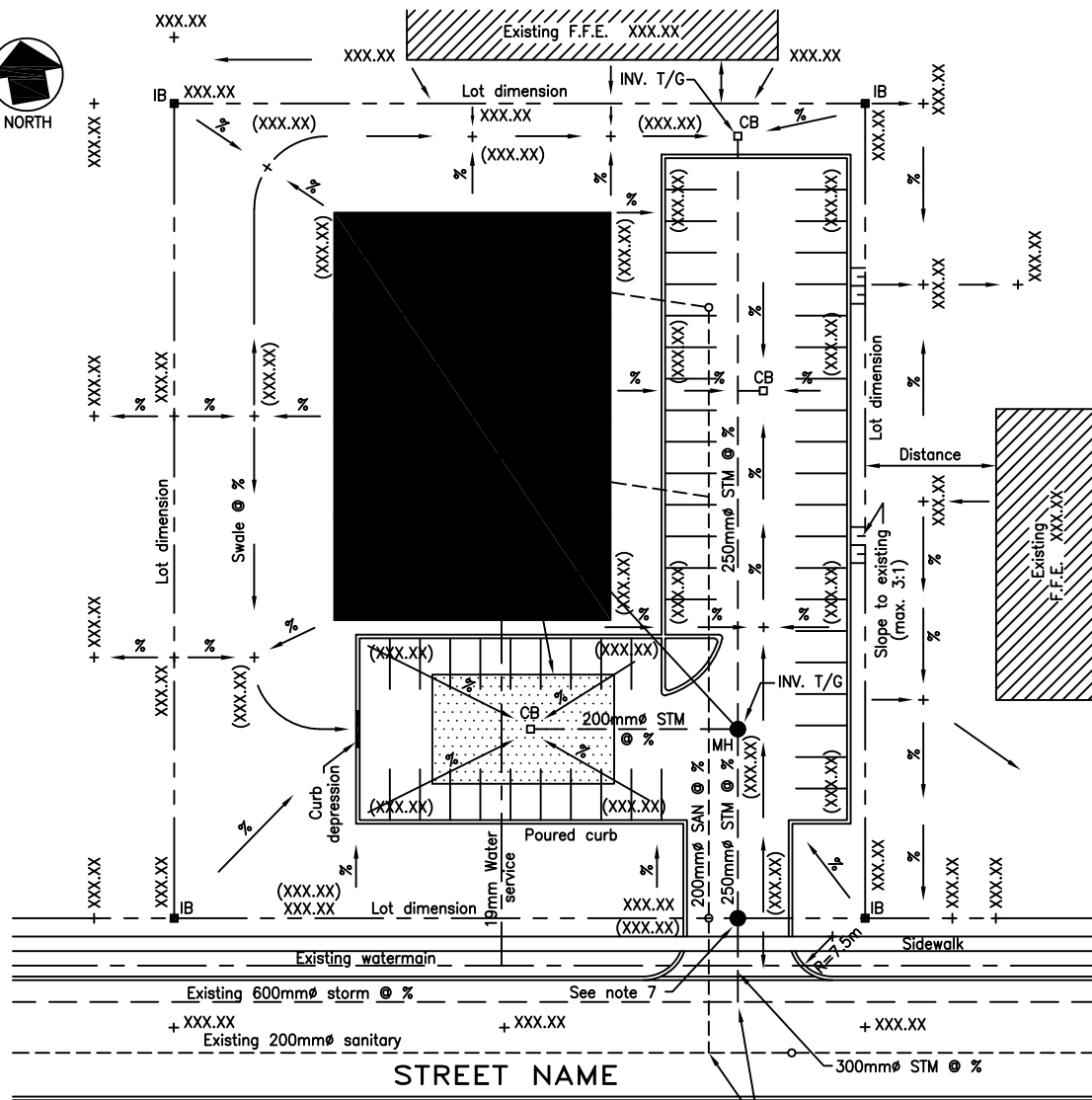

NOTES:

1. Town of Lincoln benchmark to be indicated.
2. Plan to be metric.
3. All drainage to be self-contained.
4. This drawing to be read in conjunction with Town of Lincoln Site Plan guidelines.
5. All relevant details for curb, sidewalk, sewers, orifice, oil traps, etc. should be shown.
6. Roof water leaders are not to be connected to weepers or drained to sumps.
7. Control manhole or oil trap (if required) to be placed at property line.
8. Grade changes in excess of 1.0m are to be achieved by use of a retaining wall. All retaining wall details shall be submitted.
9. GRADES:
 - a) Asphalt - min 0.5%, max. 8.0%
 - b) Grass - min. 1.0%, max. 5.0%
10. The appropriate ponding must be shown (ie. 2yr, 10yr, 100yr). The allowable ponding depths for any case are:
 - a) 0.3m max. in parking areas
 - b) 0.5m max. in landscaped areas
 - c) 1.0m in low level loading bays.
11. Sufficient ground elevations or contours on adjacent lands to be shown to permit determination of existing drainage patterns. The minimum information required would include:
 - a) Finished floor elevations of all adjacent buildings,
 - b) Existing ground surface elevations for 5 and 10 metres outside the property boundary at 20m intervals.
12. Road Occupancy Permit must be obtained prior to undertaking any works in the road allowance.

LEGEND

- (XXX.XX) Proposed elevation
- XXX.XX Existing elevation
- Flow direction
- RD Roof Drain
- CB Catch Basin
- MH Manhole
- F.F.E. Finished Floor Elevation

**INDUSTRIAL, COMMERCIAL
AND INSTITUTIONAL
GRADING AND SERVICING PLAN**

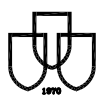

**TOWN of LINCOLN
STANDARD DRAWING**

DPW - 202

Rev. No.: 2 | Date: May 1999

Scale: N.T.S.

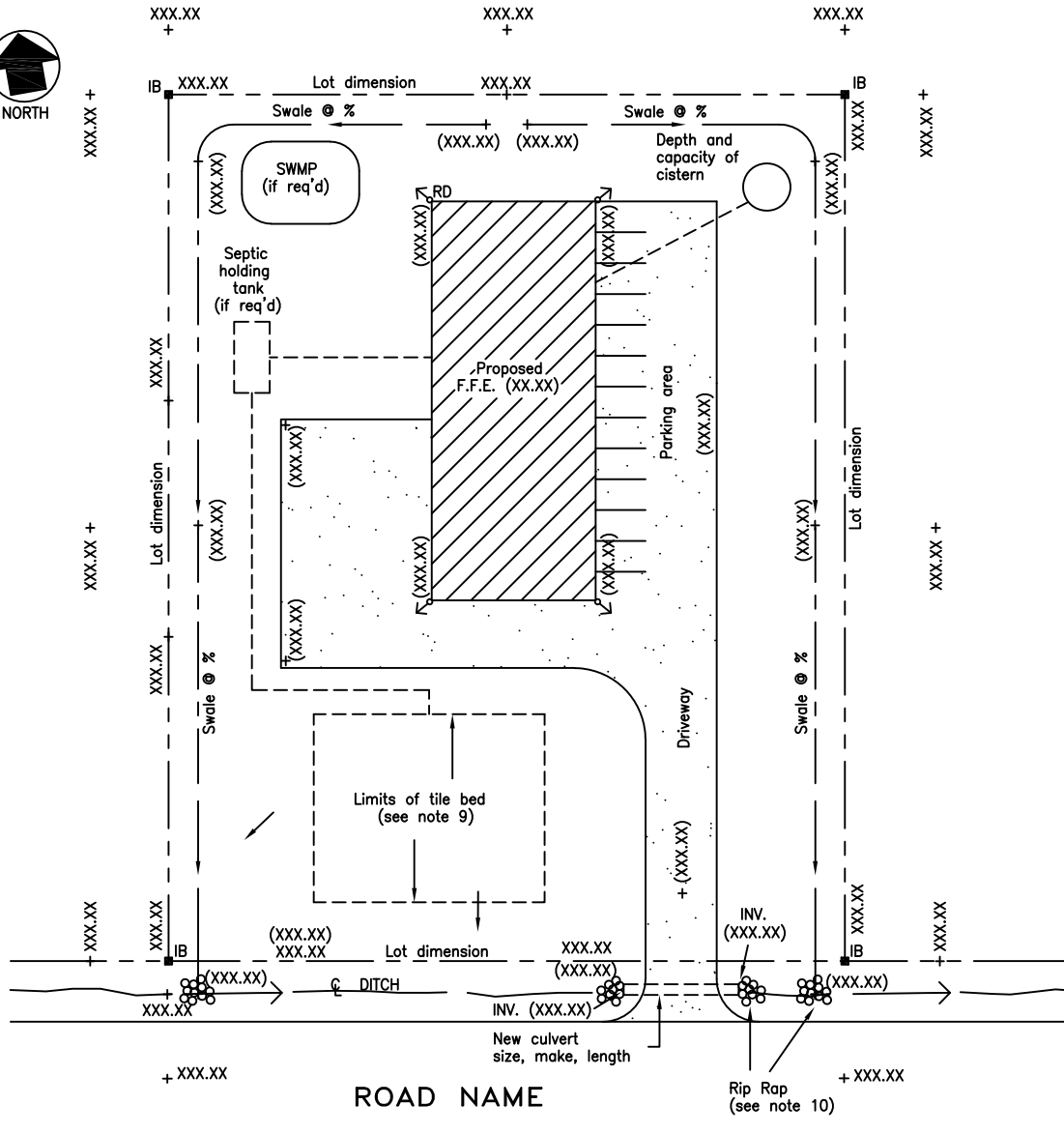

NOTES:

1. Town of Lincoln benchmark to be indicated.
2. Plan to be metric.
3. All drainage to be self-contained.
4. Grade changes in excess of 1.0m are to be achieved by use of a retaining wall. All retaining wall details shall be submitted.
5. GRADES:
 - a) Asphalt - min 0.5%, max. 8.0%
 - b) Grass - min. 1.0%, max. 5.0%
6. This drawing to be read in conjunction with Town of Lincoln Site Plan guidelines.
7. Sufficient ground elevations or contours on adjacent lands to be shown to permit determination of existing drainage patterns. The minimum information required would include:
 - a) Finished floor elevations,
 - b) Existing ground surface elevations for 5 and 10 metres outside the property boundary at 20m intervals.
8. Road Occupancy Permit must be obtained prior to undertaking any works in the road allowance.
9. All septic system requirements and tile beds to be approved by Regional Health Department.
10. Rip rap to be installed at both ends of culvert as per OPSD 810.01.

LEGEND

- (XXX.XX) Proposed elevation
- XXX.XX Existing elevation
- Flow direction
- F.F.E. Finished Floor Elevation
- SWMP Stormwater Management Pond

**RURAL
INDUSTRIAL AND COMMERCIAL
GRADING AND SERVICING PLAN**



TOWN of LINCOLN
STANDARD DRAWING

DPW - 203

Rev. No.: 1 | Date: Feb. 2002

Scale: N.T.S.

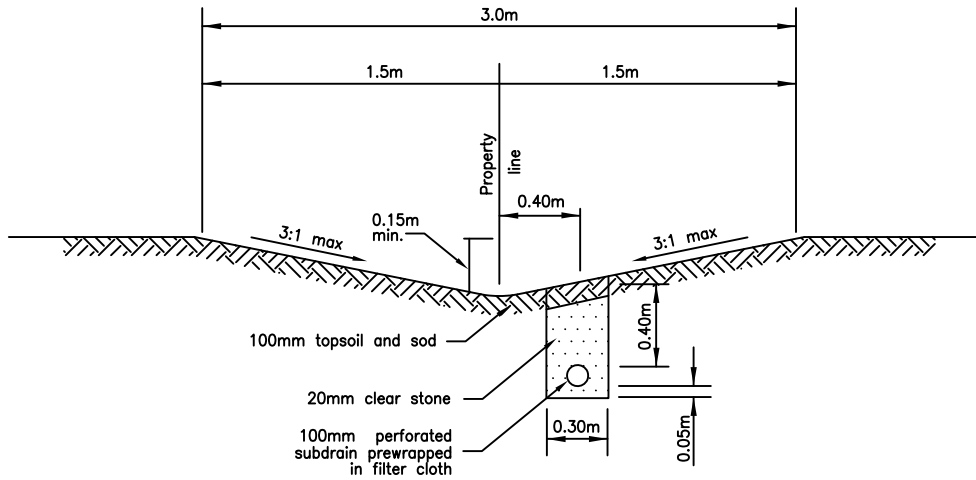

SUBDRAIN INSTALLATION
SWALE ON PROPERTY LINE

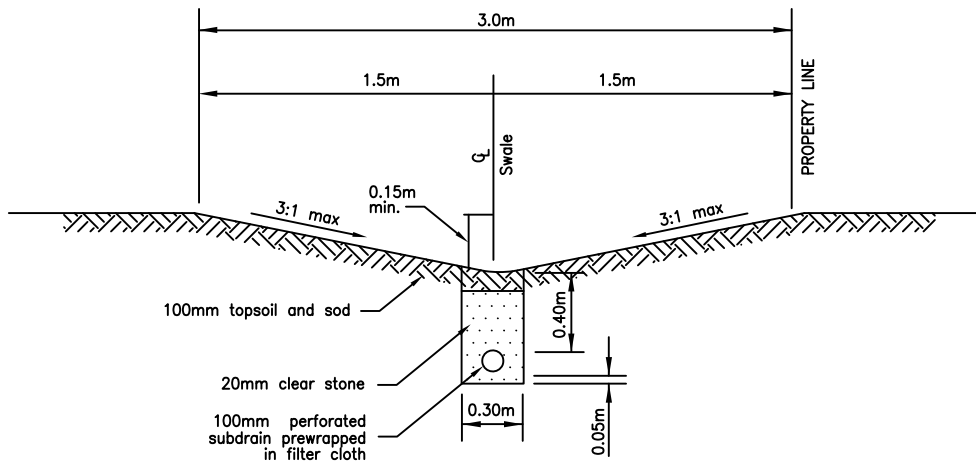

SUBDRAIN INSTALLATION
SWALE OFFSET FROM PROPERTY LINE

NOTES

1. Subdrain required for all rear yard swales with less than 1.5% slope.
2. Outlet connections are to be made on both sides of the rear yard catchbasin and shall be mortared at the inside and outside of the catchbasin walls. The subdrain shall be plugged with a manufactured plug at the high point.
3. Filter wrapped plastic subdrain pipes shall not be exposed to sunlight over a period of 10 hours.
4. Subdrain and geotextile materials in accordance with OPSS 1840 and 1860 or the most current revision.
5. All dimensions are in metres unless otherwise shown.

**REAR YARD SWALE
SUBDRAIN DETAIL**



TOWN of LINCOLN
STANDARD DRAWING

DPW - 204

Rev. No.: 1 | Date: Jan. 2007

Scale: N.T.S.



TOWN OF LINCOLN STANDARD DRAWINGS

Index

SERIES 300 - ENTRANCES AND SIDEWALK CONSTRUCTION

<u>DRAWING NO.</u>	<u>TITLE</u>
D.P.W. - 300	STANDARD ENTRANCES - LOW VOLUME ACCESS
D.P.W. - 301	STANDARD ENTRANCES - HIGH VOLUME ACCESS
D.P.W. - 302	URBAN RESIDENTIAL ENTRANCE
D.P.W. - 303	RURAL ENTRANCE TO ROAD WITH CULVERT INSTALLATION
D.P.W. - 304	STANDARD WALKWAY
D.P.W. - 305	STANDARD FOOTPATH
D.P.W. - 306	STANDARD SIDEWALK DETAIL
OPSD 310.010	CONCRETE SIDEWALK
OPSD 310.020	CONCRETE SIDEWALK ADJACENT TO CURB AND GUTTER
OPSD 310.030	CONCRETE SIDEWALK RAMPS AT INTERSECTIONS
OPSD 310.040	UTILITY ISOLATION IN SIDEWALKS
OPSD 351.010	URBAN RESIDENTIAL ENTRANCE

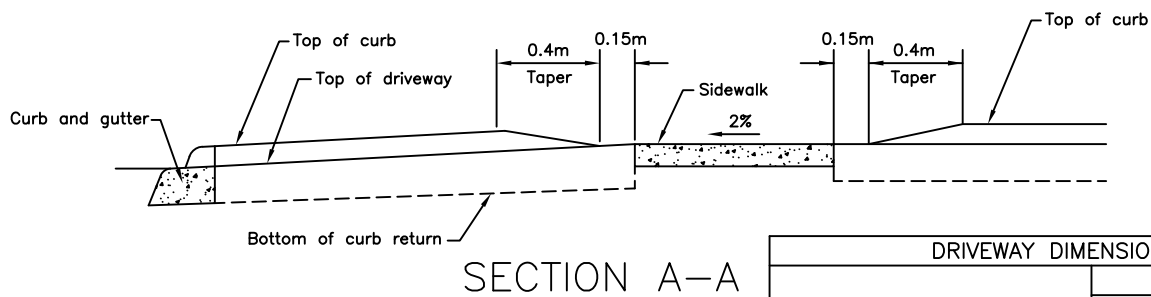
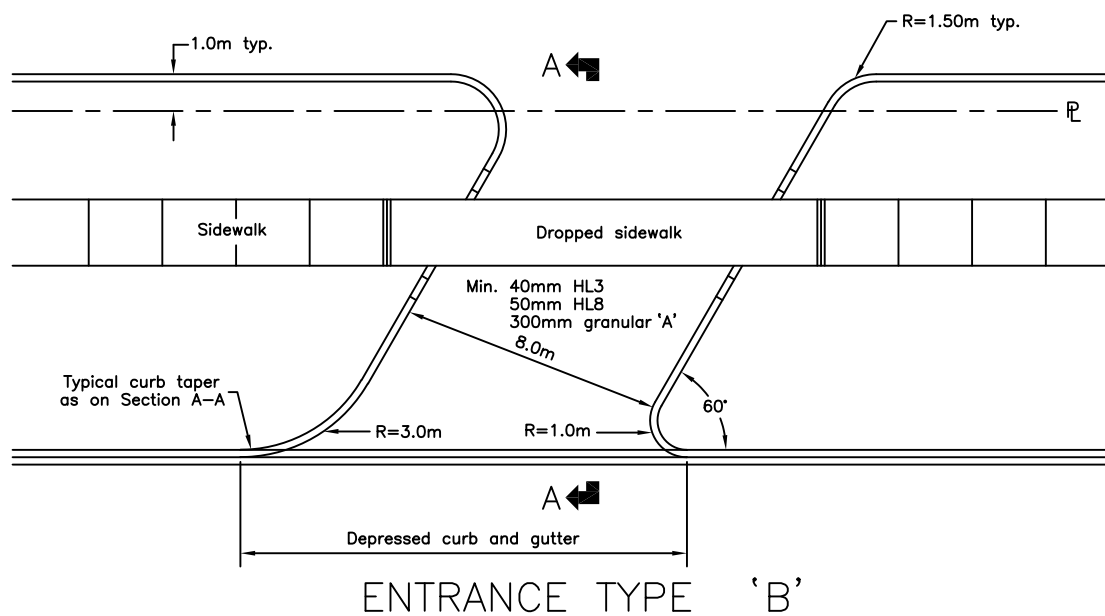
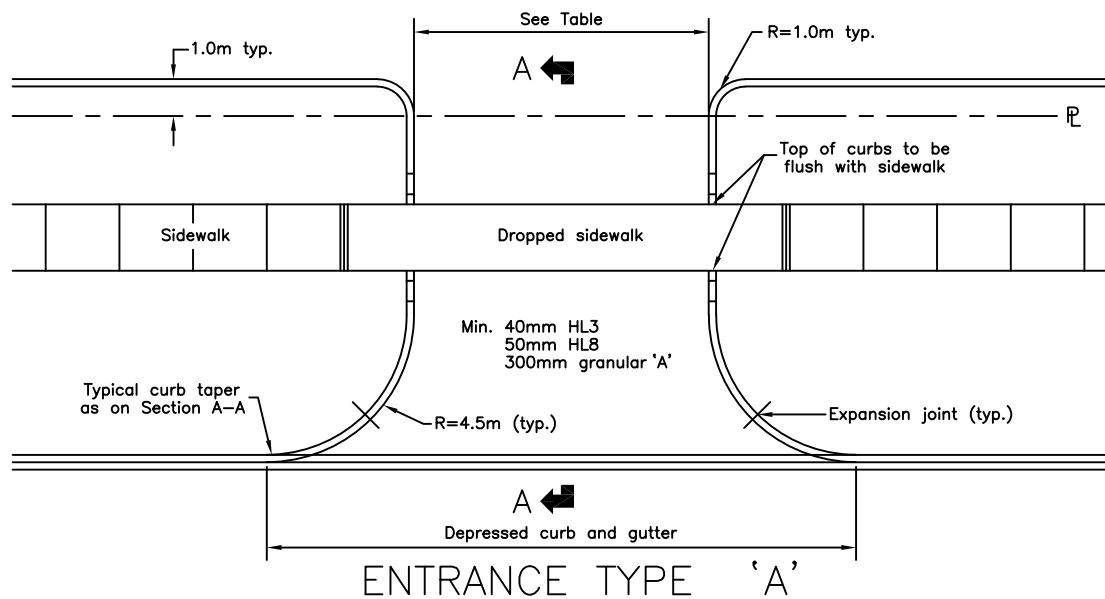

NOTES:

1. Low volume entrances to be used for local residential, local industrial and collector residential road sections.
2. All dimensions are in metres unless otherwise specified.

DRIVEWAY DIMENSIONS				
LAND USE	WIDTH (m)			
	One-Way		Two-Way	
	min	max	min	max
Light, industrial, Commercial, and Apartment	4.5	7.5	7.2	12.0
Heavy Industrial	5.0	9.0	9.0	15.0

STANDARD ENTRANCES LOW VOLUME ACCESS



TOWN of LINCOLN
STANDARD DRAWING

DPW - 300

Rev. No.: 2 Date: May 1999

Scale: N.T.S.

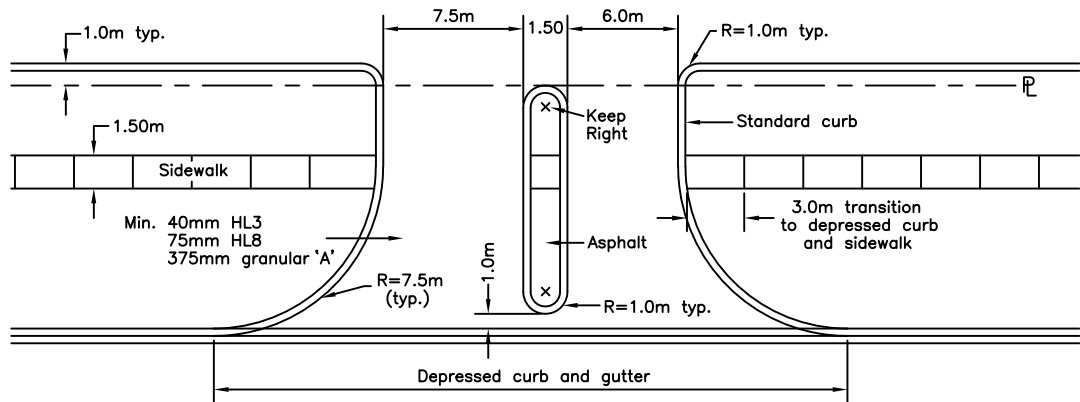

MAJOR ACCESS ENTRANCE TYPE 'C'

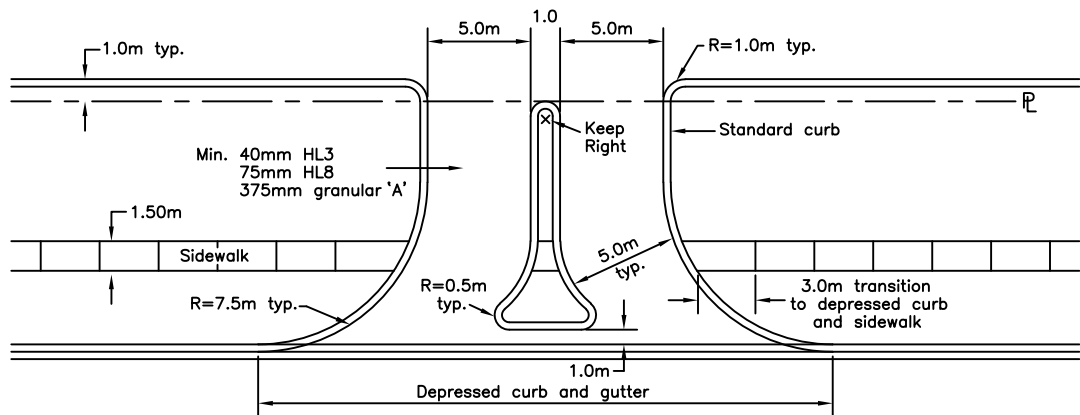

MAJOR ACCESS ENTRANCE TYPE 'D'

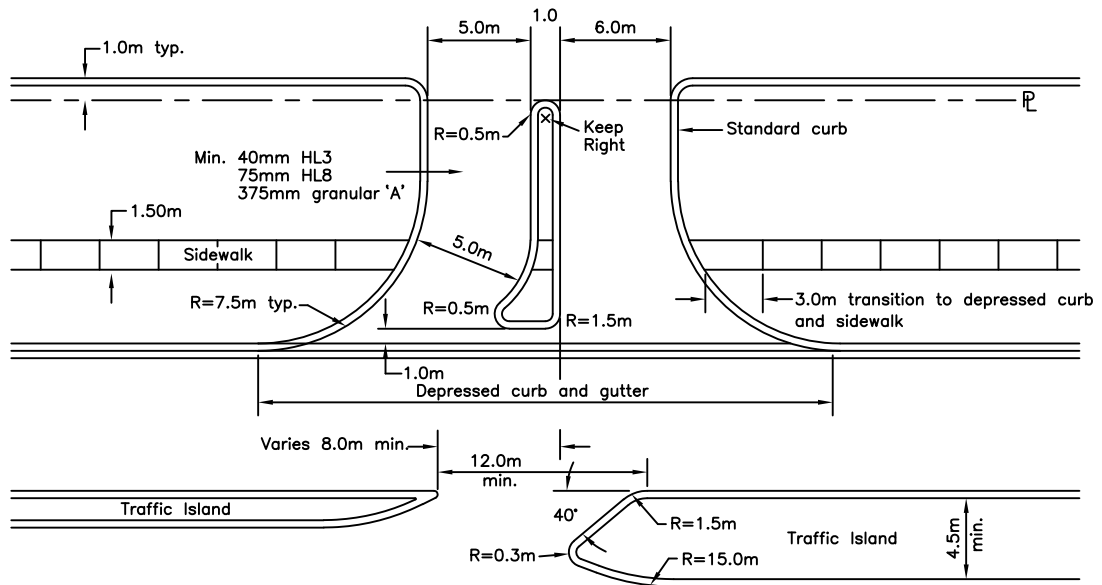

OUTCOMING LEFT TURNS RESTRICTED TYPE 'E'

NOTES:

1. High volume entrances to be used for collector industrial or arterial road sections.
2. All dimensions are in metres unless otherwise specified.

**STANDARD ENTRANCES
HIGH VOLUME ACCESS**



TOWN of LINCOLN
STANDARD DRAWING

DPW - 301

Rev. No.: 2 | Date: May 1999

Scale: N.T.S.

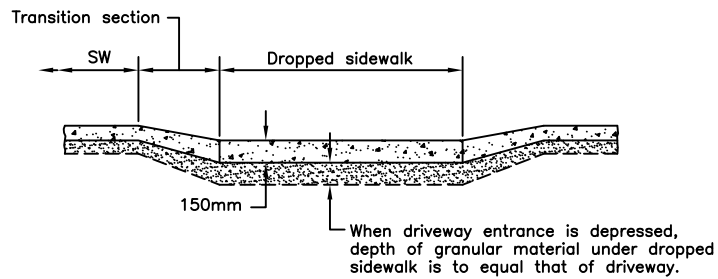
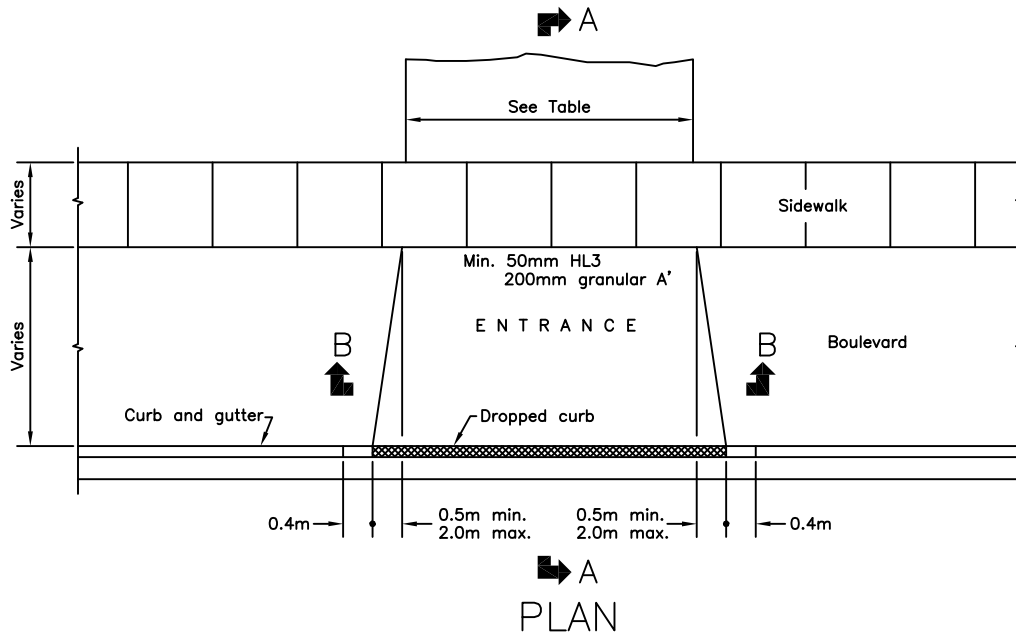

SECTION B-B

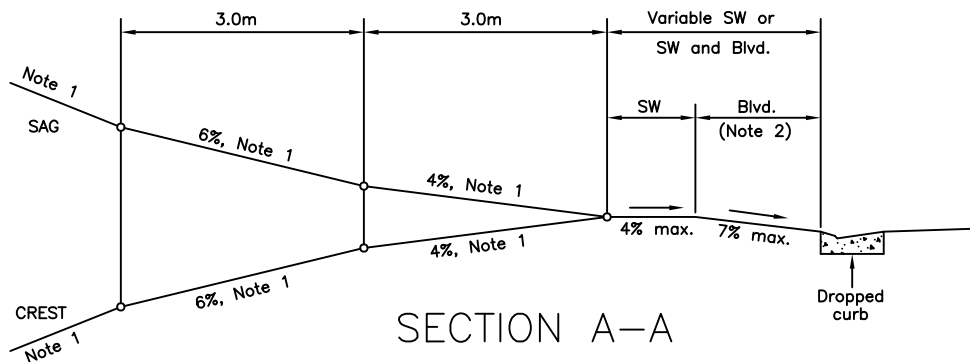

SECTION A-A

NOTES:

1. Maximum grade shall be 7%.
2. Where boulevard width is less than 3.0m, a steeper boulevard is permissible.
3. All dimensions are in metres unless otherwise shown.
4. A minimum offset of 1.0m from property lines and above ground utilities (i.e. streetlights, hydrants).

DRIVEWAY DIMENSIONS				
LAND USE	WIDTH (m)			
	Single		Double	
	min	max	min	max
Residential	3.0	4.3	6.0	7.3

URBAN RESIDENTIAL ENTRANCE



**TOWN of LINCOLN
STANDARD DRAWING**

DPW - 302

Rev. No.: 3 Date: Jan. 2018

Scale: N.T.S.

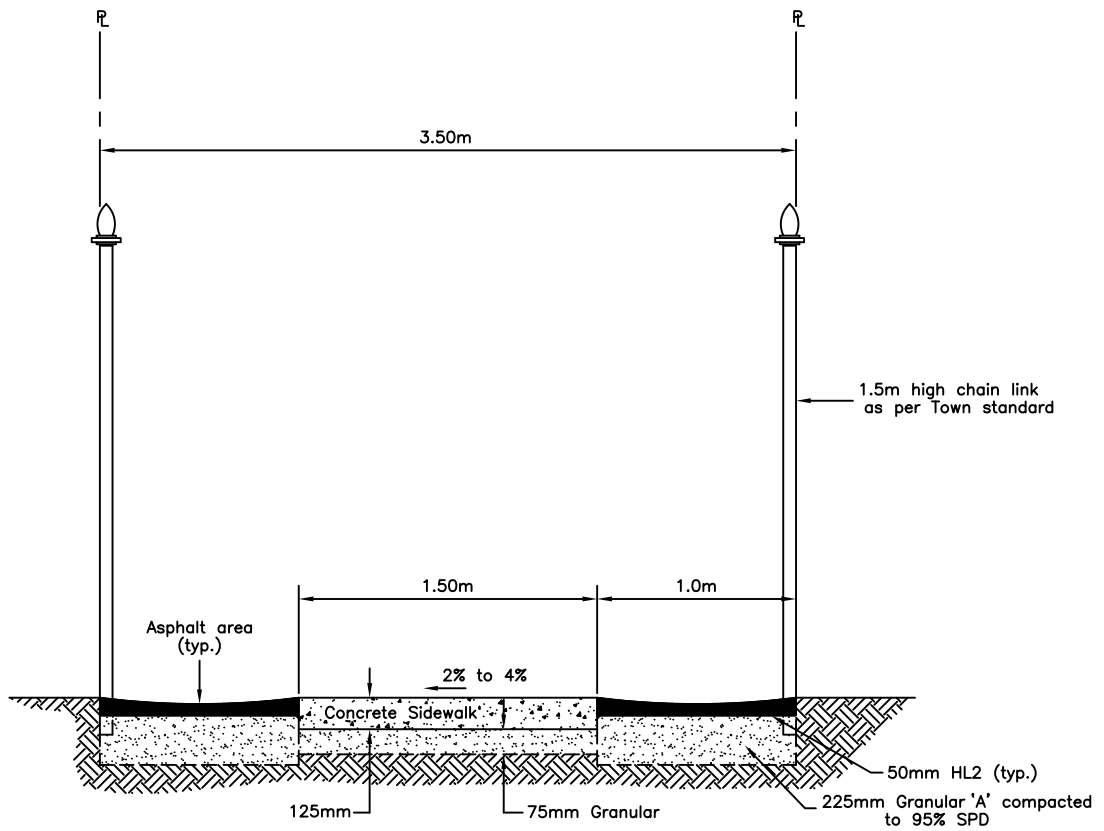

TYPICAL SECTION

NOTES

1. All dimensions are in metres unless otherwise shown.

STANDARD WALKWAY



TOWN of LINCOLN
STANDARD DRAWING

DPW - 304

Rev. No.: 3 | Date: Sept. 2000

Scale: N.T.S.

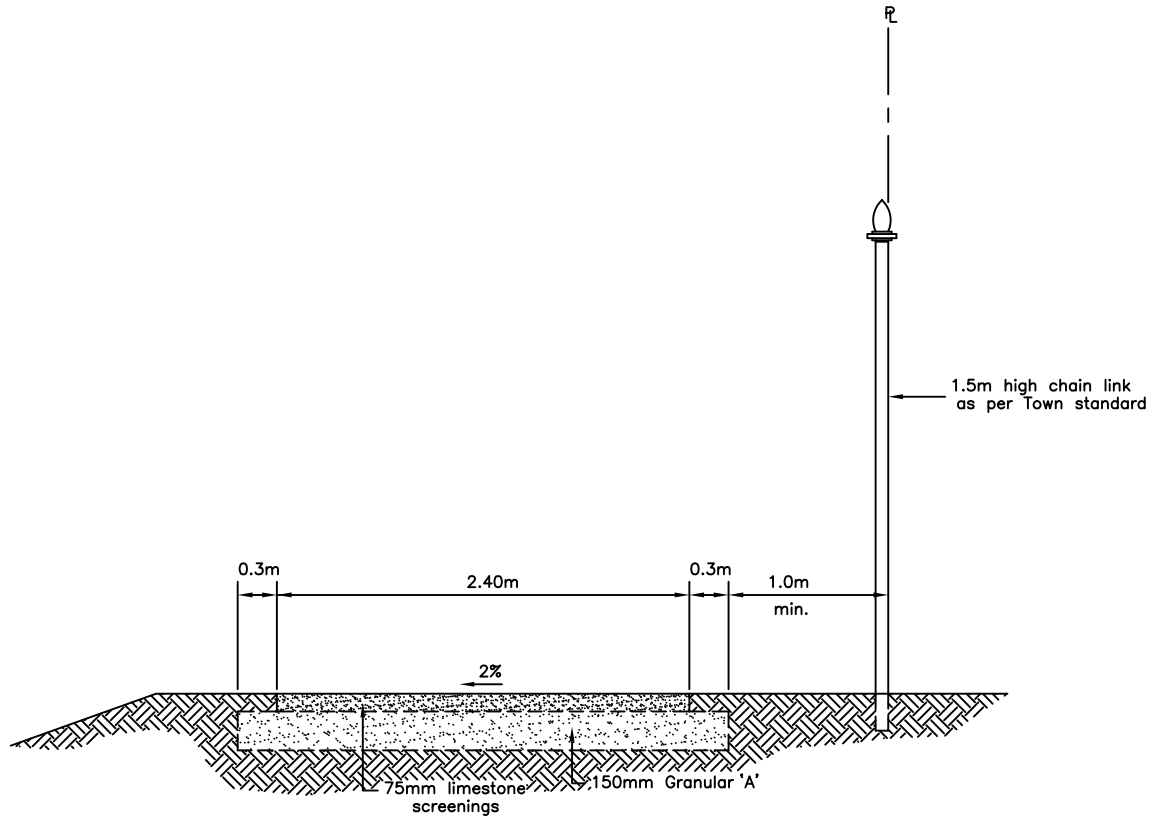

TYPICAL SECTION

NOTES

1. All dimensions are in metres unless otherwise shown.

STANDARD FOOTPATH



TOWN of LINCOLN
STANDARD DRAWING

DPW - 305

Rev. No.: 3 | Date: Sept. 2000

Scale: N.T.S.

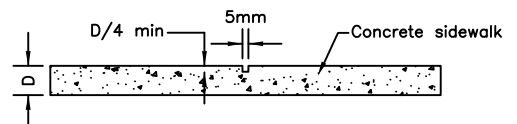
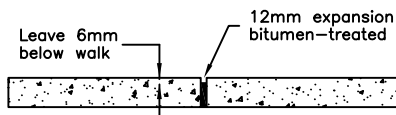
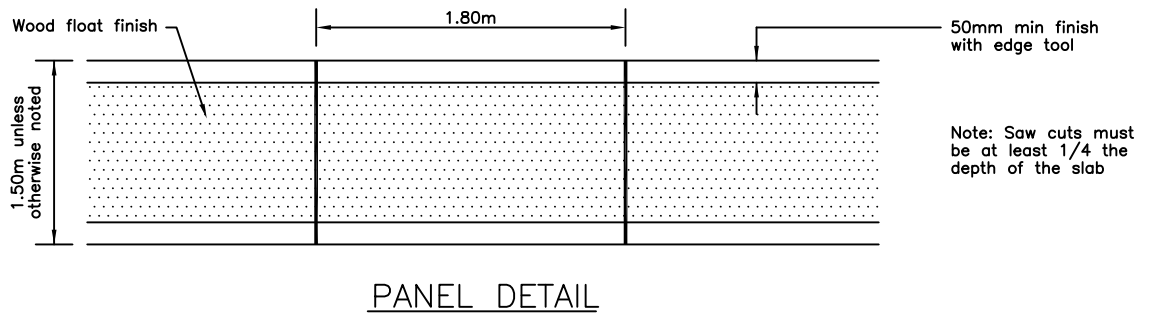
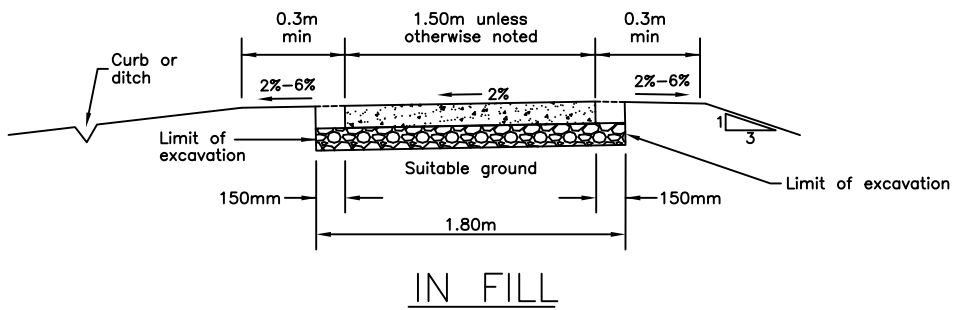
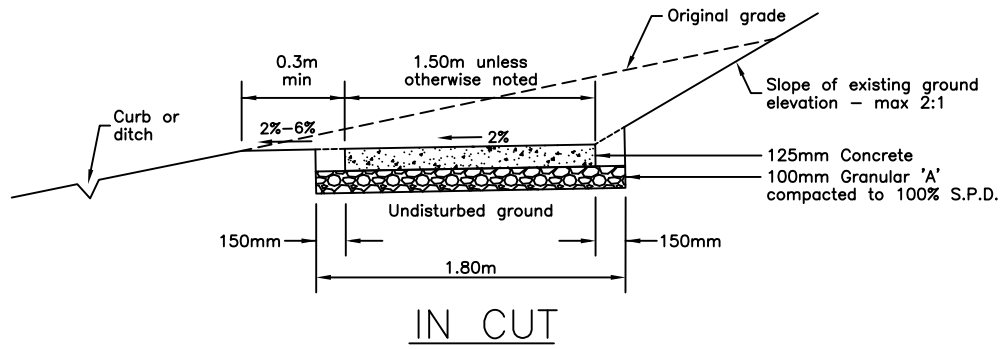

NOTES

1. The boulevard on the street side of the walk shall be graded down so as to provide adequate slop to the curb or top of ditch.
2. Residential sidewalk shall be 125mm thick, 175mm thick through residential driveways, and 200mm thick through commercial/industrial driveways.

**STANDARD SIDEWALK
DETAIL**



TOWN of LINCOLN
STANDARD DRAWING

DPW - 306

Rev. No.: 1 | Date: Jan. 2018

Scale: N.T.S.



TOWN OF LINCOLN STANDARD DRAWINGS

Index

SERIES 400 – ROADWAYS, CURBS AND GUTTERS

<u>DRAWING NO.</u>	<u>TITLE</u>
D.P.W. – 400	URBAN LOCAL ROAD SECTION AND UTILITY LOCATIONS
D.P.W. – 401	RURAL ROAD SECTION AND UTILITY LOCATIONS
D.P.W. – 402	MINOR COLLECTOR OR INDUSTRIAL ROAD
D.P.W. – 403	TURNING BASINS FOR TERMINATED URBAN ROADWAYS
D.P.W. – 404	TURNING BASIN FOR TERMINATED RURAL ROADWAYS
D.P.W. – 405	ROAD 'ELBOW' DESIGN
D.P.W. – 406	SERVICE INSTALLATION IN THE ROADWAY AREA (OPEN CUT METHOD)
D.P.W. – 407	CURB AND GUTTER SUBDRAIN
OPSD 600.040	CONCRETE BARRIER CURB WITH STANDARD GUTTER FOR FLEXIBLE PAVEMENT
OPSD 600.070	CONCRETE BARRIER CURB WITH STANDARD GUTTER TWO STAGE CONSTRUCTION
OPSD 600.110	CONCRETE BARRIER CURB

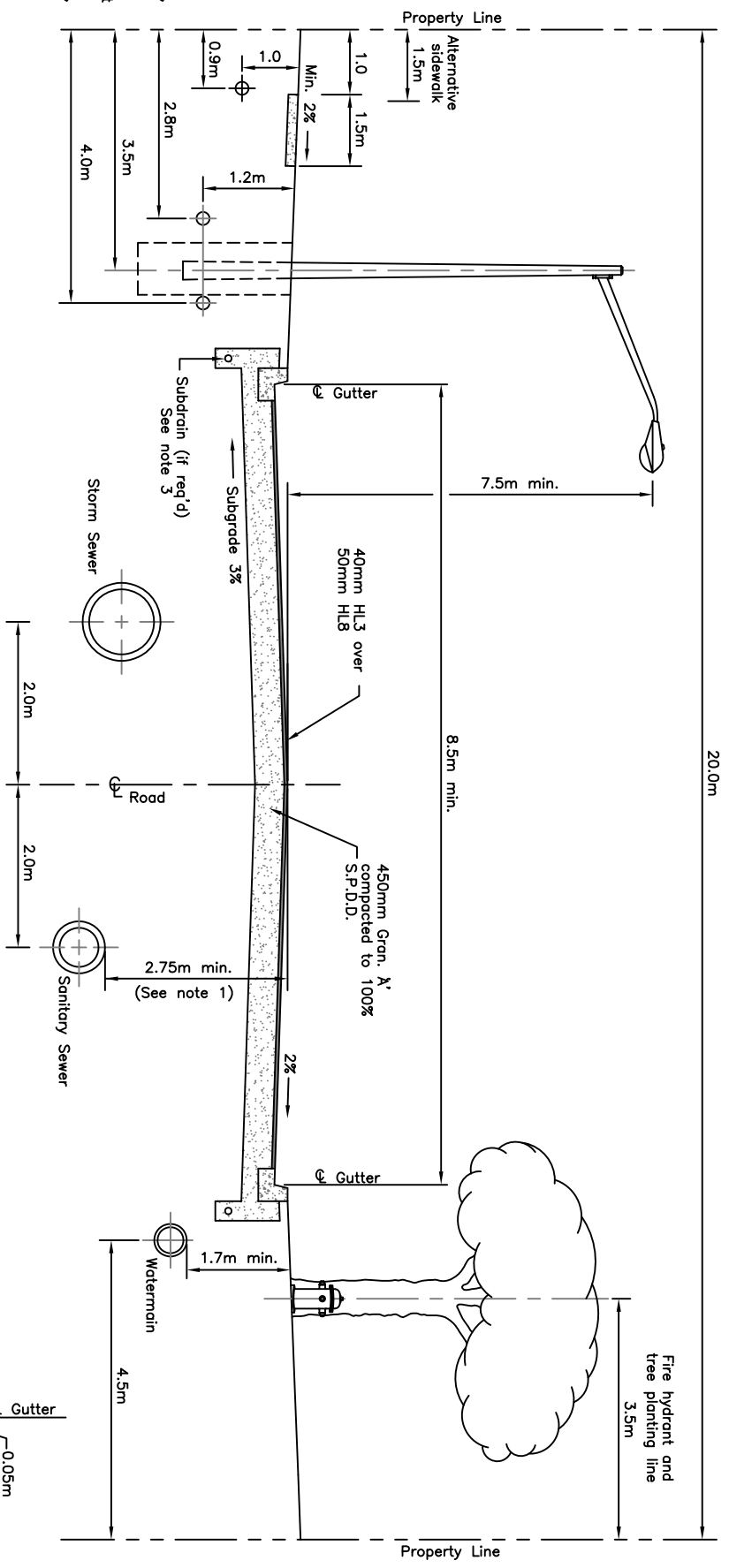

NOTES

1. Reductions in cover may be approved in certain situations.
2. Cable T.V. alternatives include joint trench with Bell and/or at rear lot where such is approved by the town.
3. Subdrains to be constructed in accordance with town standards.
4. All roadway designs are subject to recommendations and considerations addressed in a geotechnical investigation report.
5. Locations are applicable to both sides.
6. For Bell/Hydro joint installation, the trench shall be 450mm in width. Centreline of trench shall be 2.8m or alternatively 4.0m off property line.
7. All dimensions are in metres unless otherwise shown.
8. Streetlight power pedestal to be located in line with streetlight poles at lot line projections.
9. Bell and CATV pedestals to be located 0.3m From property line at the lot line projections.
10. All above ground utilities (i.e hydrants, pedestals, hydro poles, etc) must be a minimum 1.0m behind back of curb.

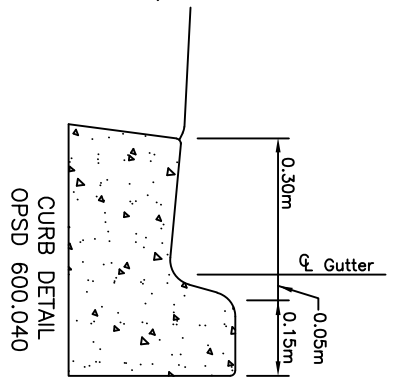

**URBAN LOCAL ROAD
SECTION AND UTILITY
LOCATIONS**



**TOWN of LINCOLN
STANDARD DRAWING**

DPW - 400

Rev. No.: 6	Date: July 2018
Scale: N.T.S.	

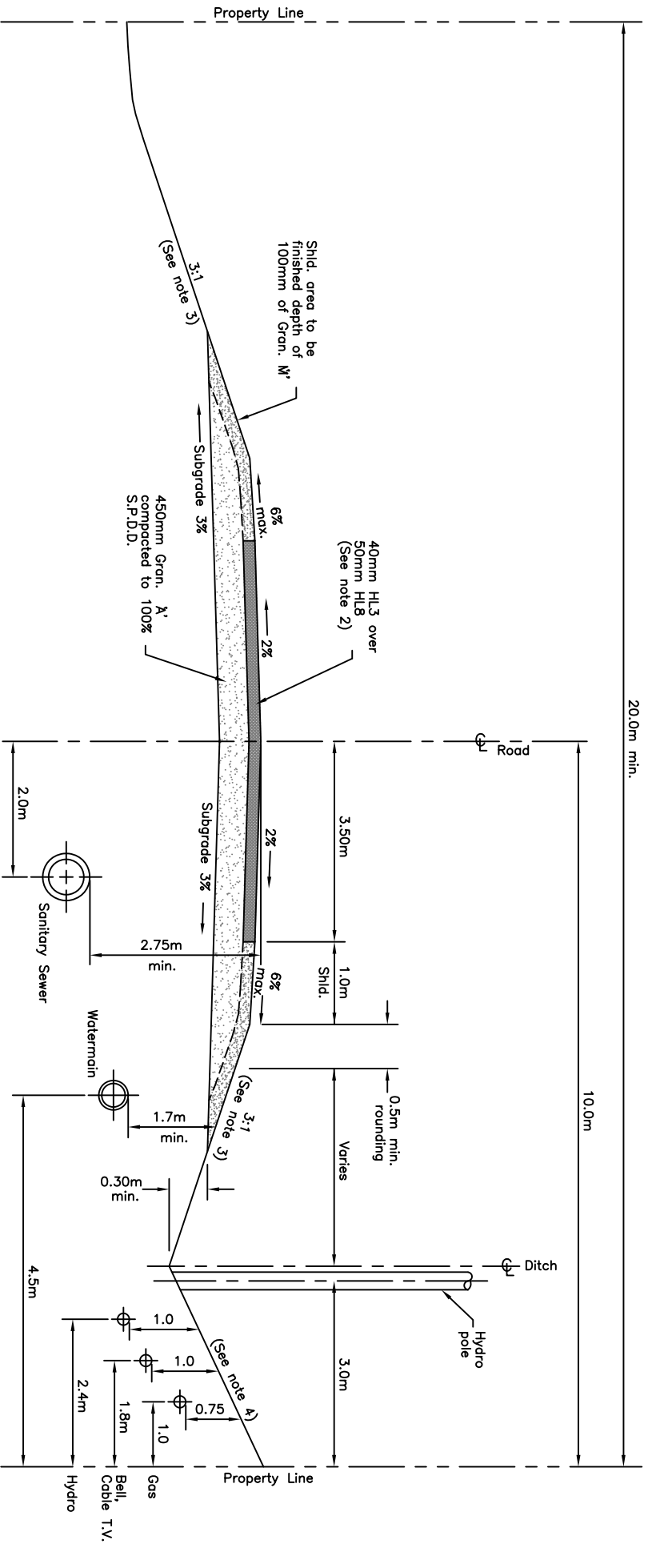

NOTES

1. Ditches to be restored with a minimum of 50mm of topsoil, seed and mulch.
2. 40mm of HL3 over 50mm of HL8 may be altered to prime and double surface treatment upon authorization of the director of public works or designate.
3. Slopes to be 3:1 for fill heights 1.0m or less; 2:1 for fills over 1.0m.
4. Backslope to be 3:1 for cuts of 1.0m or less; 2:1 for depths over 1.0m.
5. All dimensions are in metres unless otherwise shown.

FILL SECTION

CUT SECTION

RURAL ROAD SECTION AND UTILITY LOCATIONS



TOWN of LINCOLN
STANDARD DRAWING

DPW - 401

Rev. No.: 4	Date: Mar. 2005
Scale: N.T.S.	

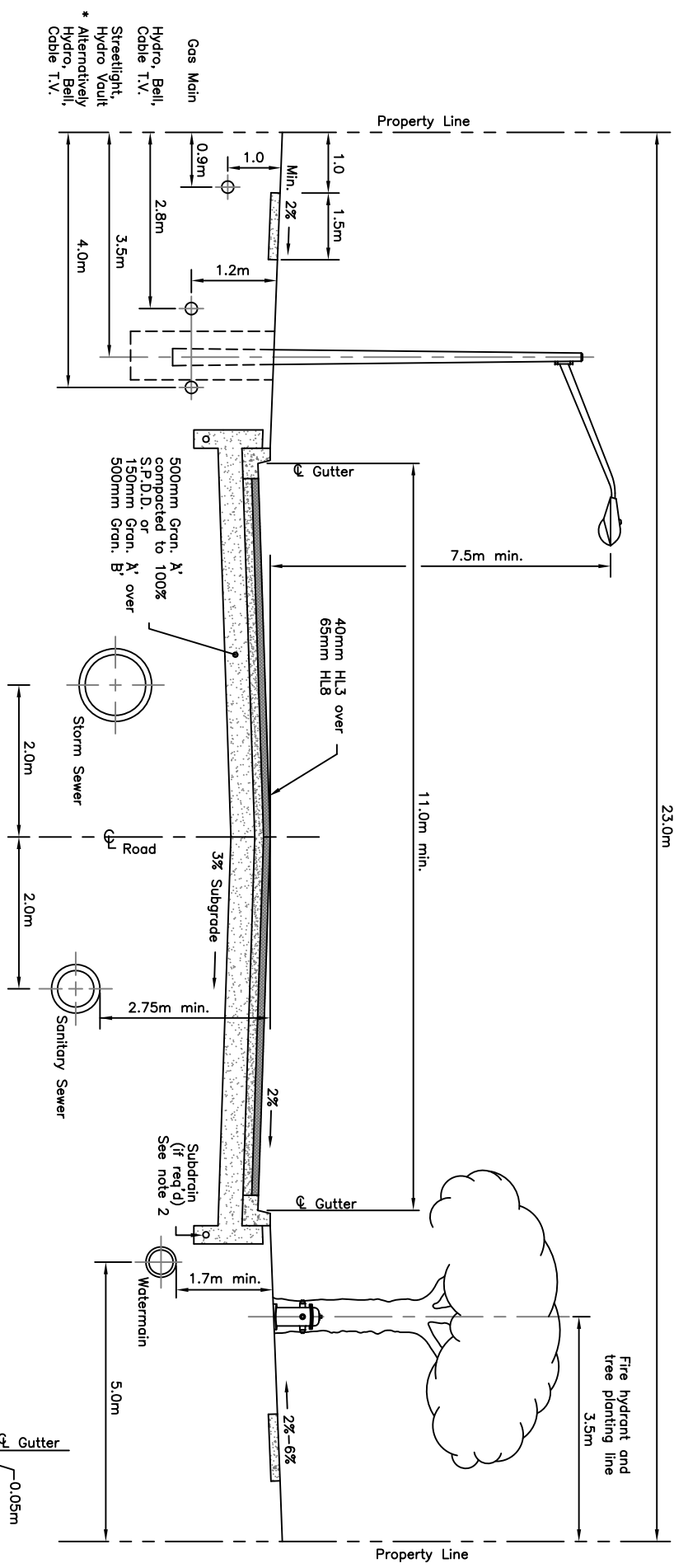

- NOTES**
1. Cable T.V. alternatives include joint trench with Bell and/or at rear lot where such is approved by the Town.
 2. Subdrains to be constructed in accordance with Town of Lincoln standards.
 3. All roadway designs are subject to recommendations and considerations addressed in a geotechnical investigation report.
 4. Locations shown are applicable to both sides.
 5. For Bell/Hydro joint installation, the trench shall be 450mm in width. Centreline of trench shall be 2.8m or alternatively 4.0m off property line.
 6. All dimensions are in metres unless otherwise shown.
 7. Streetlight power pedestal to be located in line with streetlight poles at lot line projections.
 8. Bell and CATV pedestals to be located 0.3m from property line at the lot line projections.

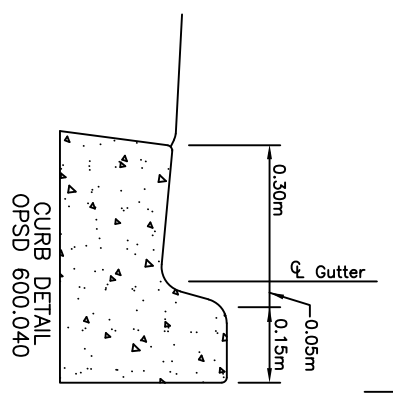

**MINOR COLLECTOR
OR
INDUSTRIAL ROAD**



DPW - 402

Rev. No.: 3	Date: Jan. 2007
Scale: N.T.S.	

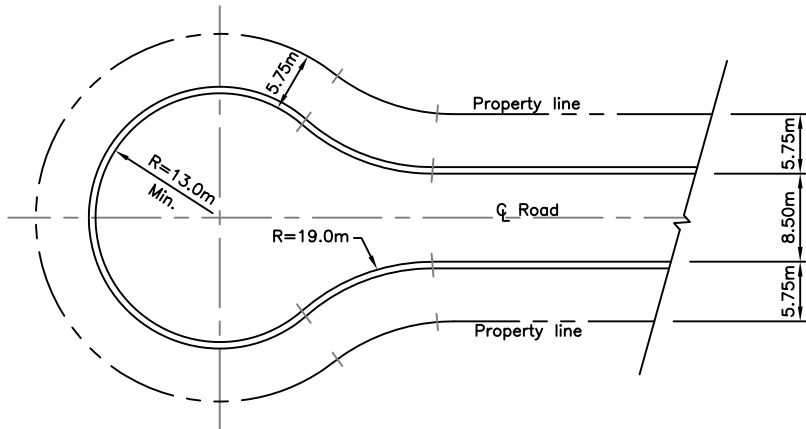

RESIDENTIAL ROAD

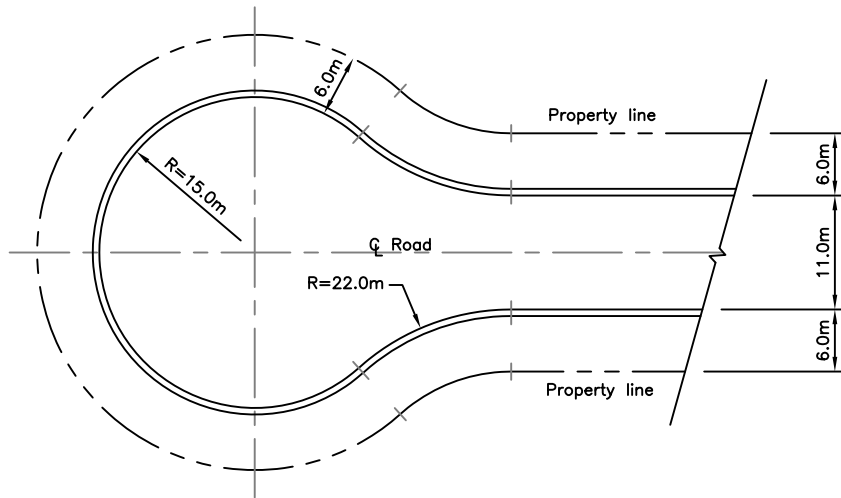

INDUSTRIAL ROAD

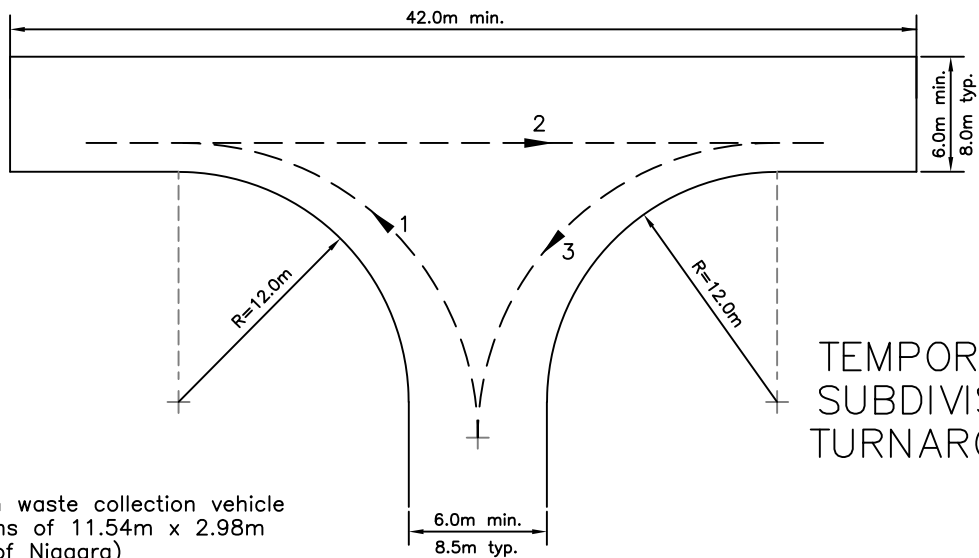

TEMPORARY
SUBDIVISION
TURNAROUND

NOTE

Based on waste collection vehicle
Dimensions of 11.54m x 2.98m
(Region of Niagara)

**TURNING BASINS FOR
TERMINATED URBAN
ROADWAYS**



TOWN of LINCOLN
STANDARD DRAWING

DPW - 403

Rev. No.: 5 | Date: July 2018

Scale: N.T.S.

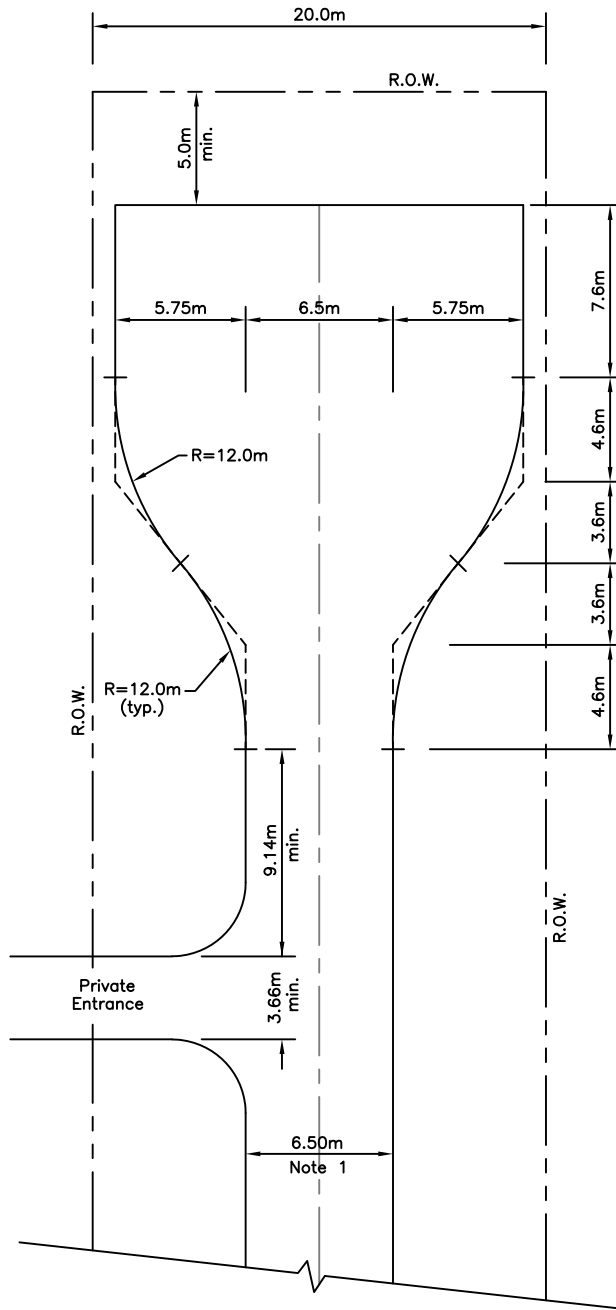

NOTES

1. Width of pavement shoulder and rounding to match terminated roadway.
2. Drainage as shown on the contract documents.
3. Dimensions shown are for either side of roadway.
3. All dimensions are in metres unless otherwise shown.

**TURNING BASIN FOR
TERMINATED RURAL
ROADWAYS**



TOWN of LINCOLN
STANDARD DRAWING

DPW - 404

Rev. No.: 2 | Date: May 1999

Scale: N.T.S.

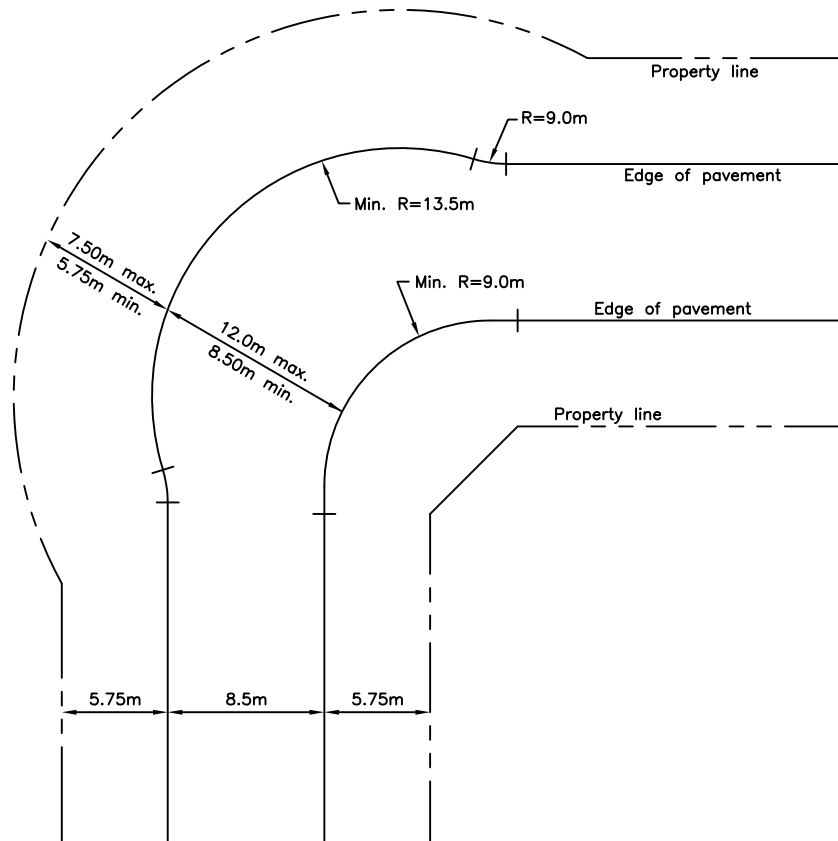

NOTES

1. Adjacent driveways shall have a 1.0m minimum separation at the curb.
2. The minimum centreline grade shall be 0.70% with a minimum gutter grade of 0.50%
3. All dimensions are in metres unless otherwise shown.

ROAD 'ELBOW' DESIGN



**TOWN of LINCOLN
STANDARD DRAWING**

DPW - 405

Rev. No.: 2 | Date: May 1999

Scale: N.T.S.

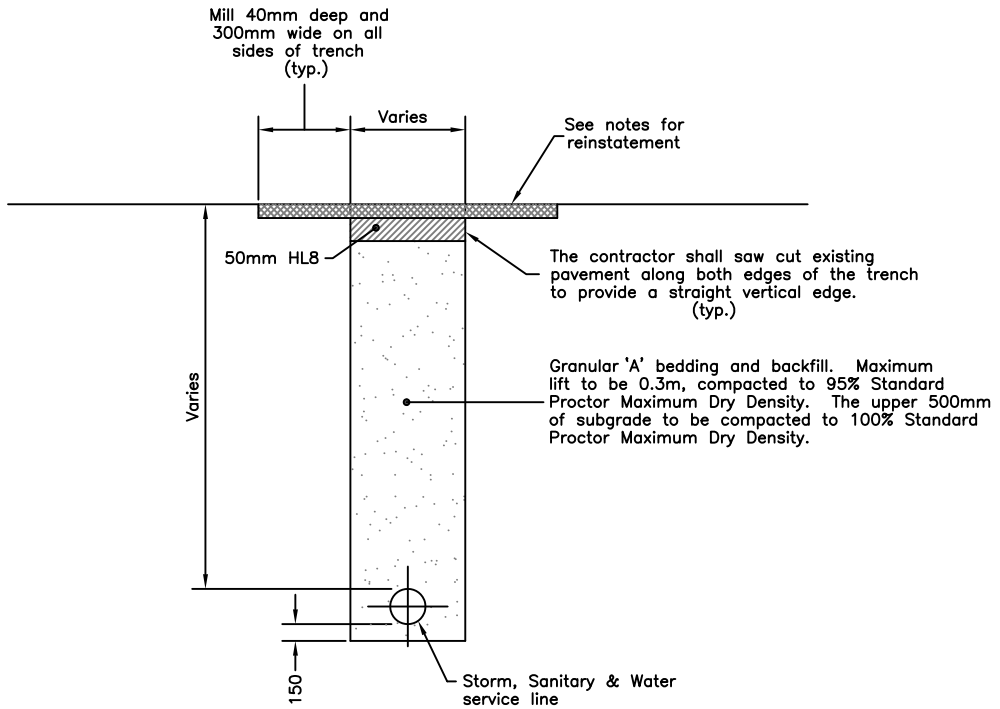

NOTES FOR ASPHALT REINSTATEMENT

1. TEMPORARY:
Cold mix 90mm in trench or 90mm HL8. The contractor shall maintain cold mix asphalt regularly prior to final reinstatement.
2. FINAL:
Removal of cold mix (if applicable). Mill 40mm deep and 300mm wide on all sides of the trench. Place compacted 50mm HL8 in trench. Top with compacted 40mm HL3 in both trench and milling areas.

**SERVICE INSTALLATION IN
THE ROADWAY AREA
(Open Cut Method)**



TOWN of LINCOLN
STANDARD DRAWING

DPW - 406

Rev. No.: 2 | Date: May 1999

Scale: N.T.S.

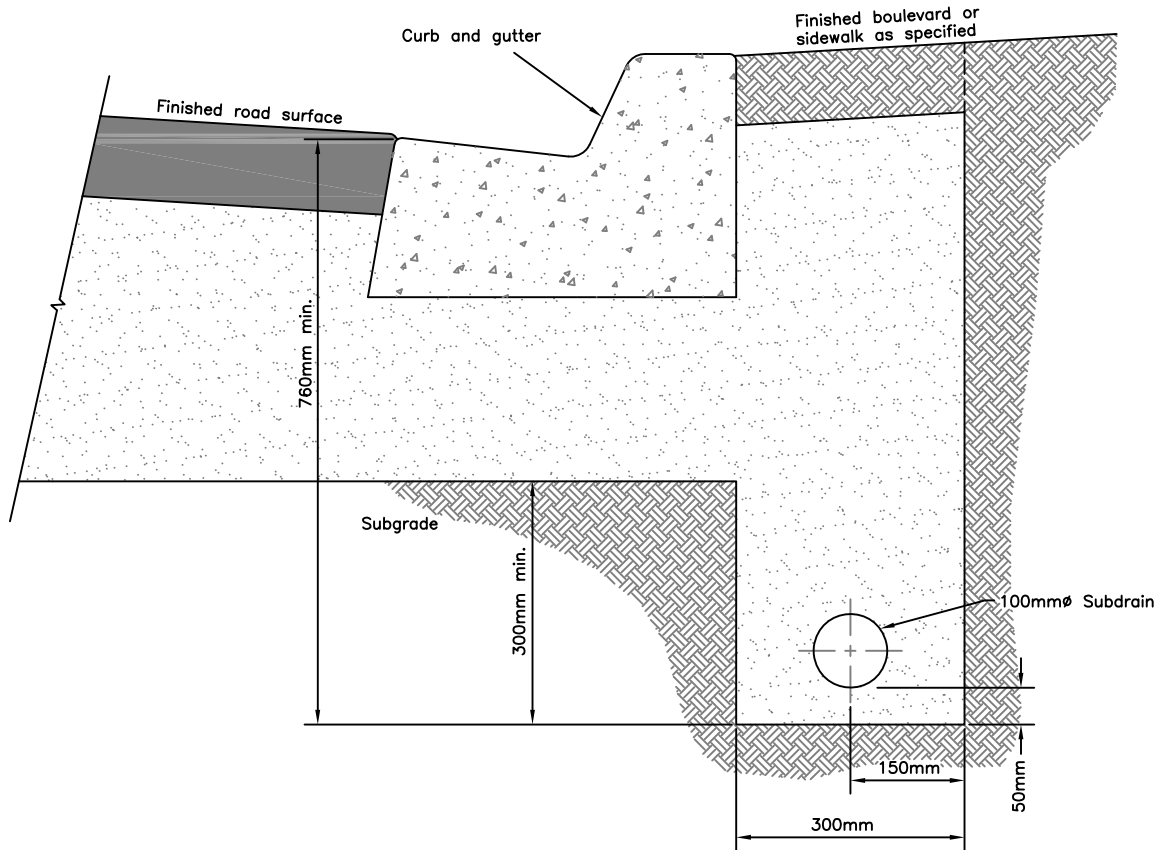

INSTALLATION DETAIL

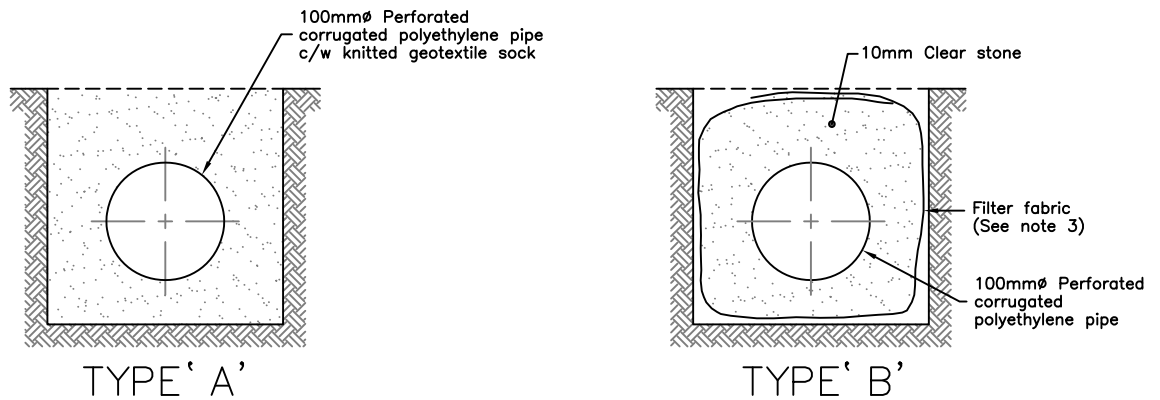

ALTERNATE TYPES OF SUBDRAIN

NOTES

1. All connections to be made on both sides of the catchbasin and to be mortared at the inside and outside of the catchbasin walls. The subdrain shall be plugged with a manufactured plug at the high point.
2. Filter wrapped plastic subdrain pipes shall not be exposed to sunlight over a period of 10 hours.
3. Filter fabric shall be in accordance with town specifications.
4. Subdrain and geotextile materials in accordance with OPSS 1840 and 1860 or the most current revision.
5. All dimensions are in millimetres unless otherwise shown.

CURB AND GUTTER SUBDRAIN



TOWN of LINCOLN
STANDARD DRAWING

DPW - 407

Rev. No.: 4 Date: Mar. 2005

Scale: N.T.S.



TOWN OF LINCOLN STANDARD DRAWINGS

Index

SERIES 500 – SANITARY AND STORM SEWERS

<u>DRAWING NO.</u>	<u>TITLE</u>
D.P.W. – 500	TRENCH BEDDING AND EMBEDMENT FOR PIPES
D.P.W. – 501	SEWER LATERAL CONNECTIONS
D.P.W. – 502	SITE SERVICING ALTERNATIVES
D.P.W. – 503	STANDARD SEWER LATERAL INSTALLATIONS
D.P.W. – 504	SUMP PUMP LATERAL INSTALLATION
D.P.W. – 505	SANITARY CLEANOUT (LANDSCAPED AREAS)
D.P.W. – 506	SANITARY CLEANOUT (HARD SURFACES)
D.P.W. – 507	PRECAST CATCH BASIN WITHOUT SUMP
D.P.W. – 508	SANITARY BACKWATER VALVE INSTALLATION DETAIL RESIDENTIAL LATERAL
OPSD 400.020	CAST IRON, SQUARE FRAME WITH SQUARE FLAT GRATE FOR CATCH BASINS, HERRING BONE OPENINGS
OPSD 401.010	CAST IRON, SQUARE FRAME WITH CIRCULAR CLOSED OR OPEN COVER FOR MAINTENANCE HOLES
OPSD 403.010	GALVANIZED STEEL HONEY COMB GRATING FOR DITCH INLET
OPSD 404.020	ALUMINUM SAFETY PLATFORM FOR CIRCULAR MAINTENANCE HOLE
OPSD 405.020	MAINTENANCE HOLE STEPS – SOLID
OPSD 701.010	PRECAST CONCRETE MAINTENANCE HOLE – 1200mm DIAMETER
OPSD 701.011	PRECAST CONCRETE MAINTENANCE HOLE – 1500mm DIAMETER
OPSD 701.012	PRECAST MAINTENANCE CAPS HOLE – 1800mm DIAMETER
OPSD 701.013	PRECAST MAINTENANCE CAPS HOLE – 2400mm DIAMETER
OPSD 701.021	MAINTENANCE HOLE BENCHING AND PIPE OPENING DETAILS
OPSD 705.010	PRECAST CONCRETE CATCH BASIN 600mm x 600mm
OPSD 705.030	PRECAST CONCRETE DITCH INLET 600mm x 600mm
OPSD 1003.010	CAST-IN-PLACE MAINTENANCE HOLE DROP STRUCTURE – TEE
OPSD 1003.020	CAST-IN-PLACE MAINTENANCE HOLE DROP STRUCTURE – WYE

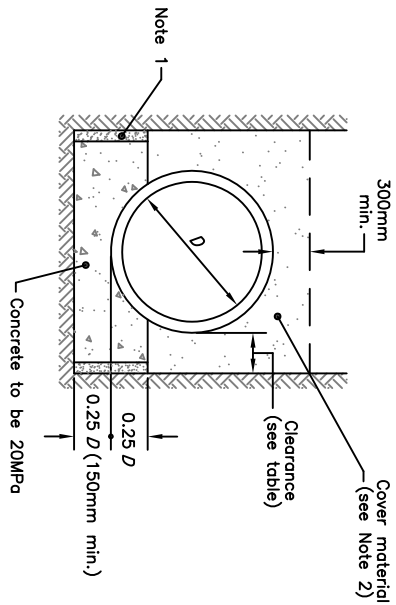

TYPE 'A'
CONCRETE CRADLE

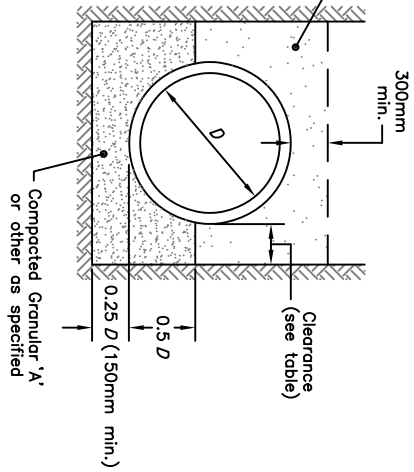

TYPE 'B'
GRANULAR TO SPRINGLINE

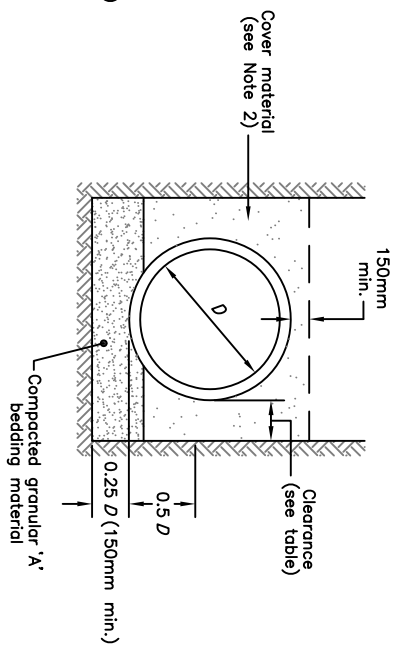

TYPE 'C'
GRANULAR FOUNDATION

Pipe Inside diameter (mm)	Min. Working Clearance (mm)
900 or less	300
Over 900	500

NOTES

1. In rock excavation provide a 50mm layer of compressible material between trench walls and concrete.
2. Cover material – no stones greater than 25mm will be permitted.
3. In rock excavation a minimum of 150mm granular material bedding is required underneath the pipe.
4. The pipe bed is to be carefully shaped to receive the lowest segment of pipe.
5. All dimensions are in millimetres unless otherwise shown.

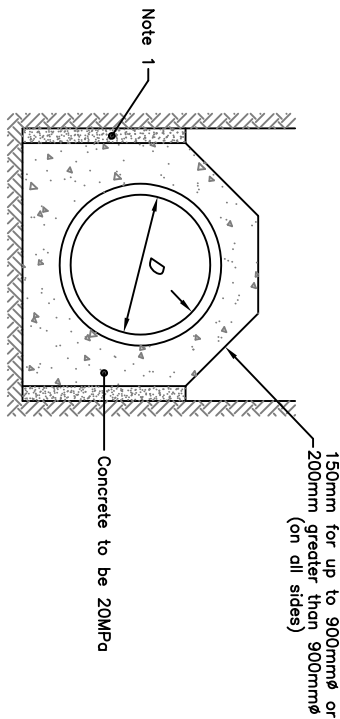

TYPE 'D'
CONCRETE ENCASEMENT

TRENCH BEDDING AND
EMBEDMENT FOR
PIPES



TOWN of LINCOLN
STANDARD DRAWING

DPW - 500

Rev. No.: 2 Date: May 1999
Scale: N.T.S.

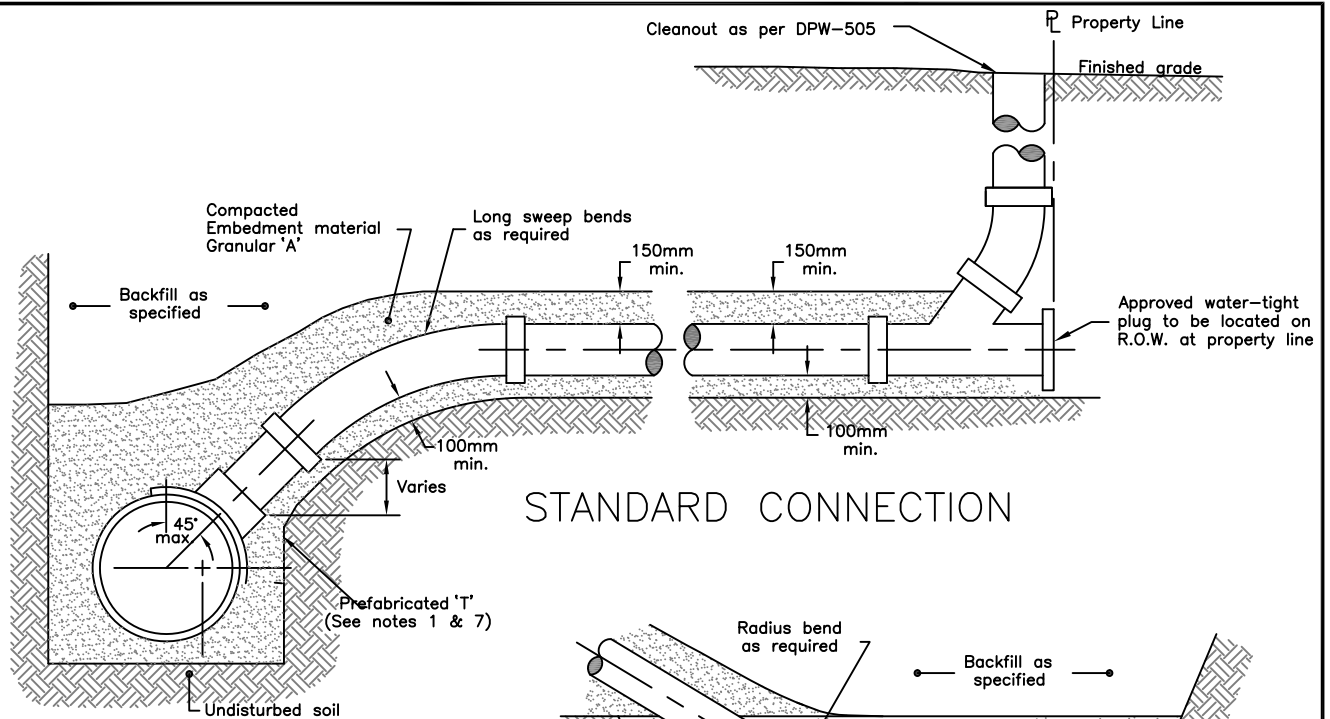

STANDARD CONNECTION

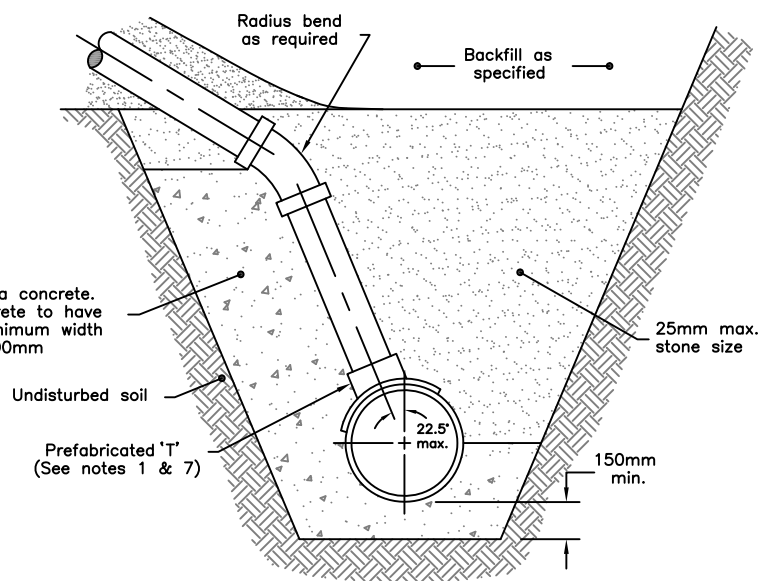

VERTICAL RISER DETAIL
(RIGID PIPE ONLY)

NOTES

1. For sewers smaller than 300mm ϕ , connections must be made using factory made tees. For all other sizes, either factory made tees or approved strap-on saddles may be used.
2. Strap-on saddles must be installed on the main pipe before that pipe is laid.
3. Approved cut-in tool must be used for field made tees.
4. Service connection must be securely plugged at property line with an expanding type plug or an approved equal.
5. Plug at property line shall be adequately braced to withstand testing pressures.
6. Double connections shall be made using a factory made wye.
7. For connections into existing sanitary main sewers, an approved manufactured saddle may be used. Saddle must have two straps and be coupled together with stainless steel bolts.
8. Standard connection sizes – residential sanitary 125mm ϕ , residential storm 100mm ϕ .
9. For sanitary sewers – minimum grade 20mm/m.
10. For storm sewers – minimum grade 10mm/m.
11. Wood stake min. 150mm above grade, painted green for sanitary sewer lateral and red for storm sewer lateral.
12. Cleanout and omni ball marker to be installed at property line as per DPW-505.
13. All dimensions are in millimetres unless otherwise shown.

**SEWER
LATERAL CONNECTIONS**



**TOWN of LINCOLN
STANDARD DRAWING**

DPW - 501

Rev. No.: 4 Date: Jan. 2018

Scale: N.T.S.

NOTES:

For all 3 alternatives:

1. All dimensions are in metres unless otherwise shown.

LEGEND

For all 3 alternatives:

- X approx. locations for hydro meter
- - - approx. locations for U/G hydro line
- △ sanitary cleanout
- water service curb stop

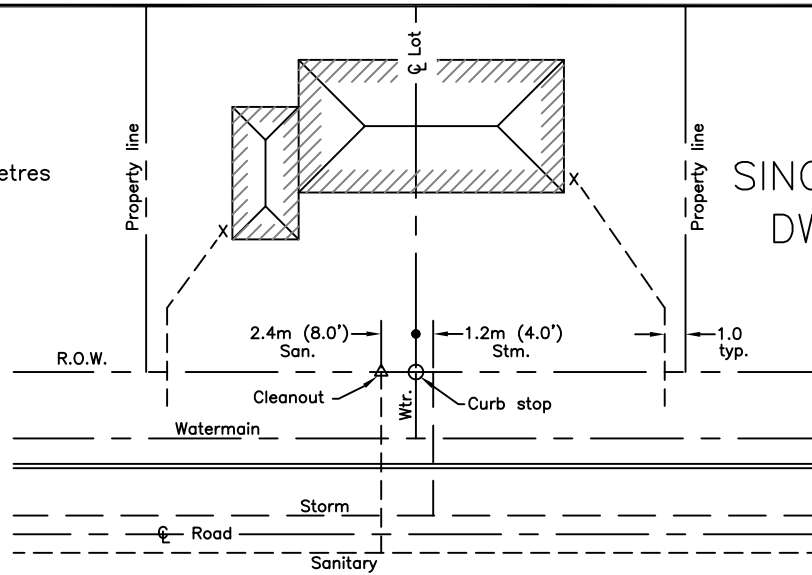

SINGLE FAMILY DWELLING

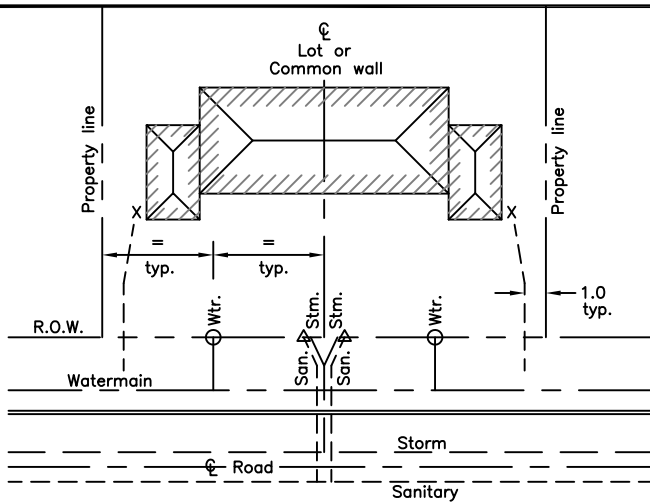

Option A

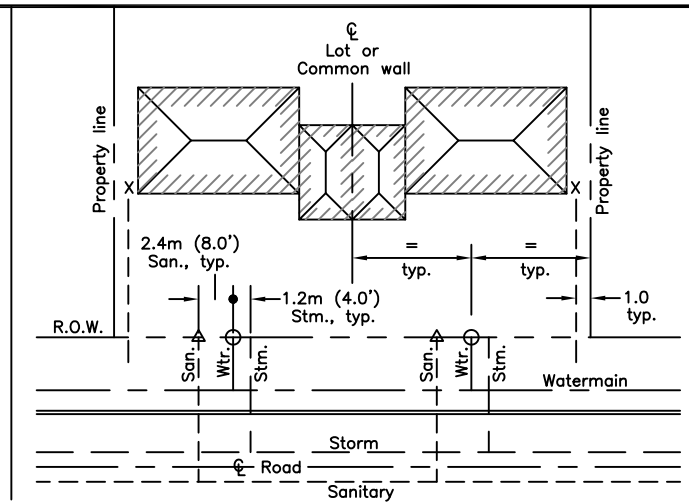

Option B

DUPLEX UNIT

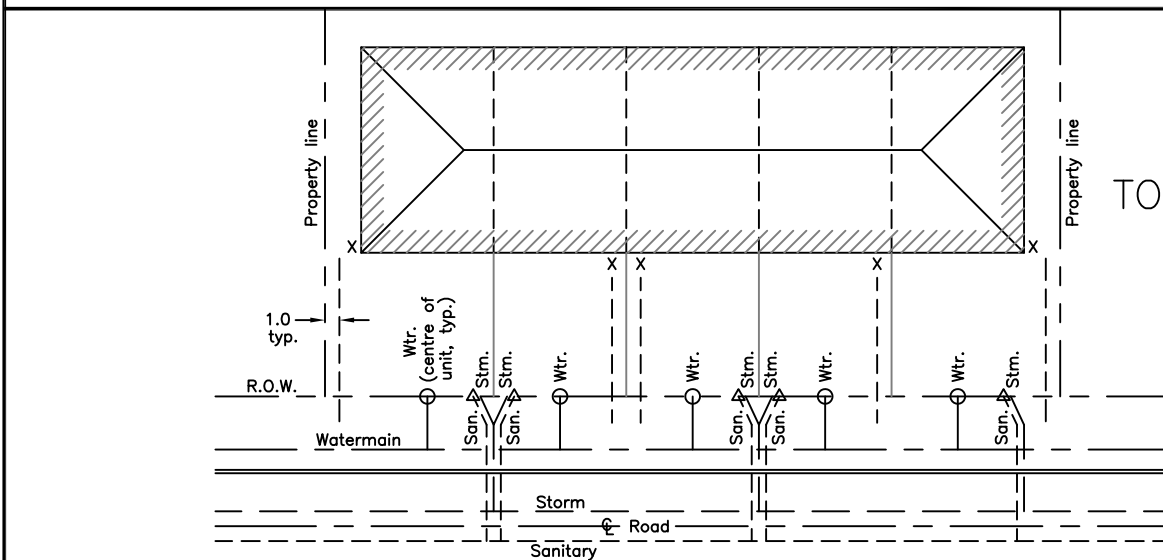

BLOCK TOWNHOUSE

SITE SERVICING ALTERNATIVES



TOWN of LINCOLN
STANDARD DRAWING

DPW - 502

Rev. No.: 3 | Date: Jan. 2018

Scale: N.T.S.

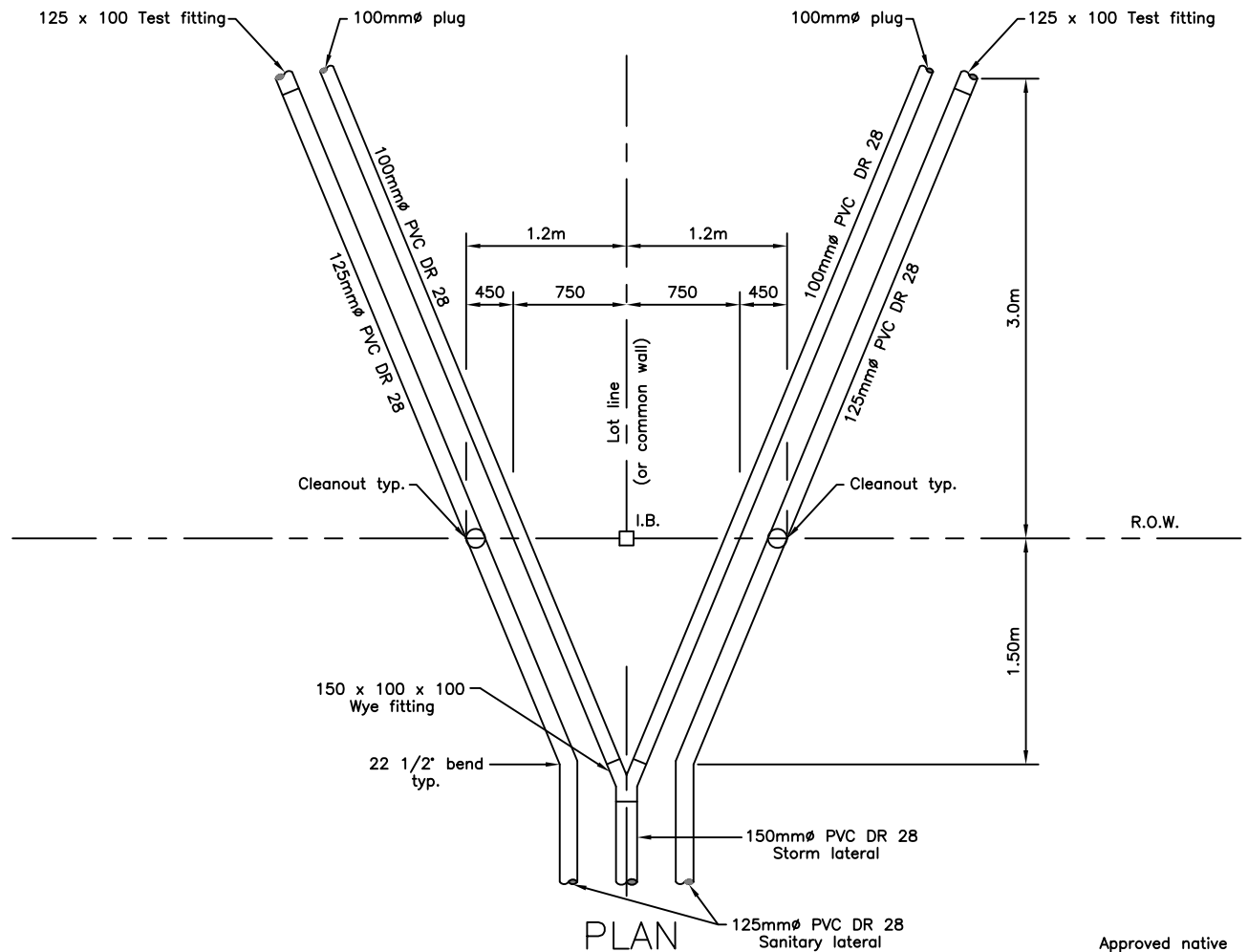

PLAN
(Double Connection)

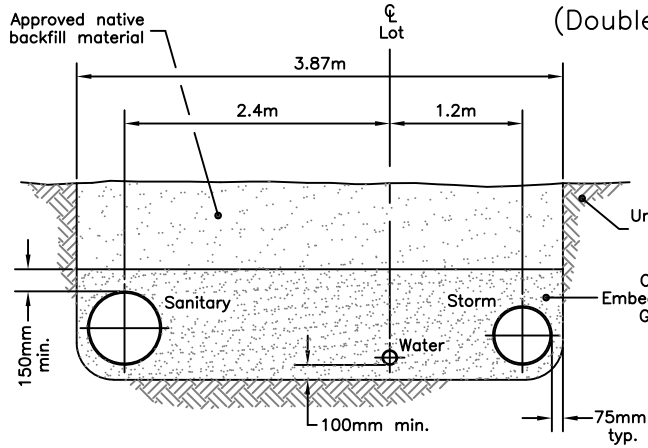

BEDDING DETAIL
(Single Connection)

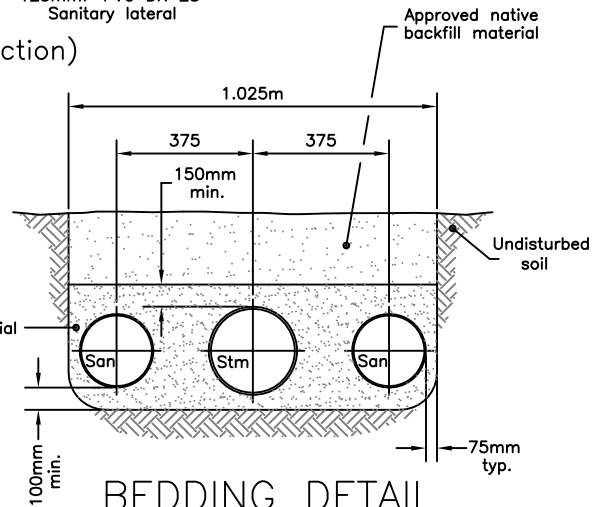

BEDDING DETAIL
(Double Connection)

NOTES:

1. Connections are not to be placed on previously disturbed ground.
2. For connecting laterals to main pipe, use DPW-501.
3. Driveways not to be placed directly over laterals.
4. Sanitary pipe to be colour green and storm pipe to be colour white.
5. Cleanout and omni ball marker to be installed at property line as per DPW-505.
5. All dimensions are in millimetres unless otherwise shown.

STANDARD SEWER LATERAL INSTALLATION



TOWN of LINCOLN
STANDARD DRAWING

DPW - 503

Rev. No.: 4 Date: Jan. 2018

Scale: N.T.S.

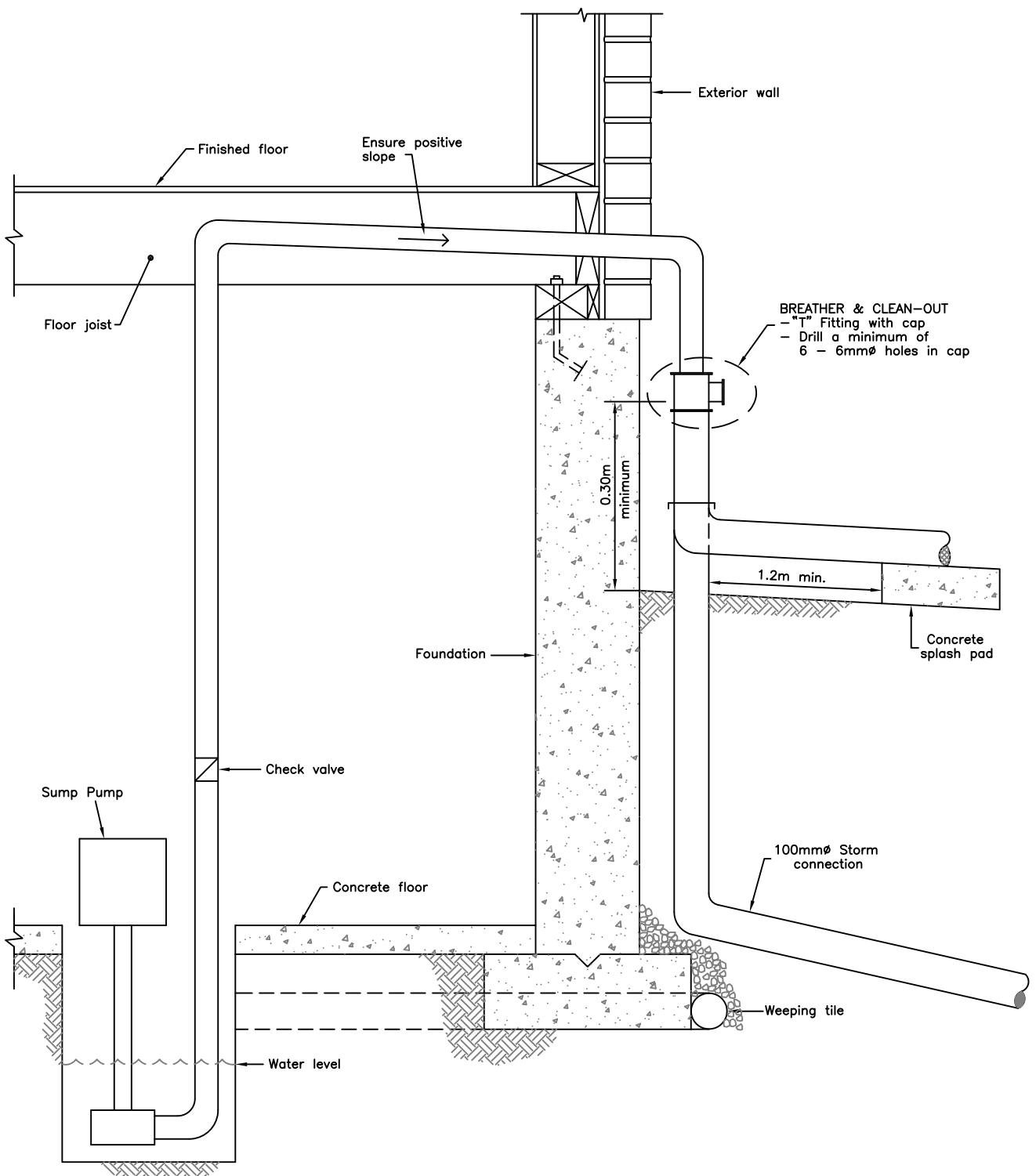

NOTES

1. For storm sewer lateral location at property line see servicing drawings.
2. Other minor variations may be approved by Building Dep't.
3. Sump pump and piping installation to be inspected by Building Dep't.
4. Sump pump required for all residential buildings.

SUMP PUMP LATERAL INSTALLATION



TOWN of LINCOLN
STANDARD DRAWING

DPW - 504

Rev. No.: 3 | Date: June 2003

Scale: N.T.S.

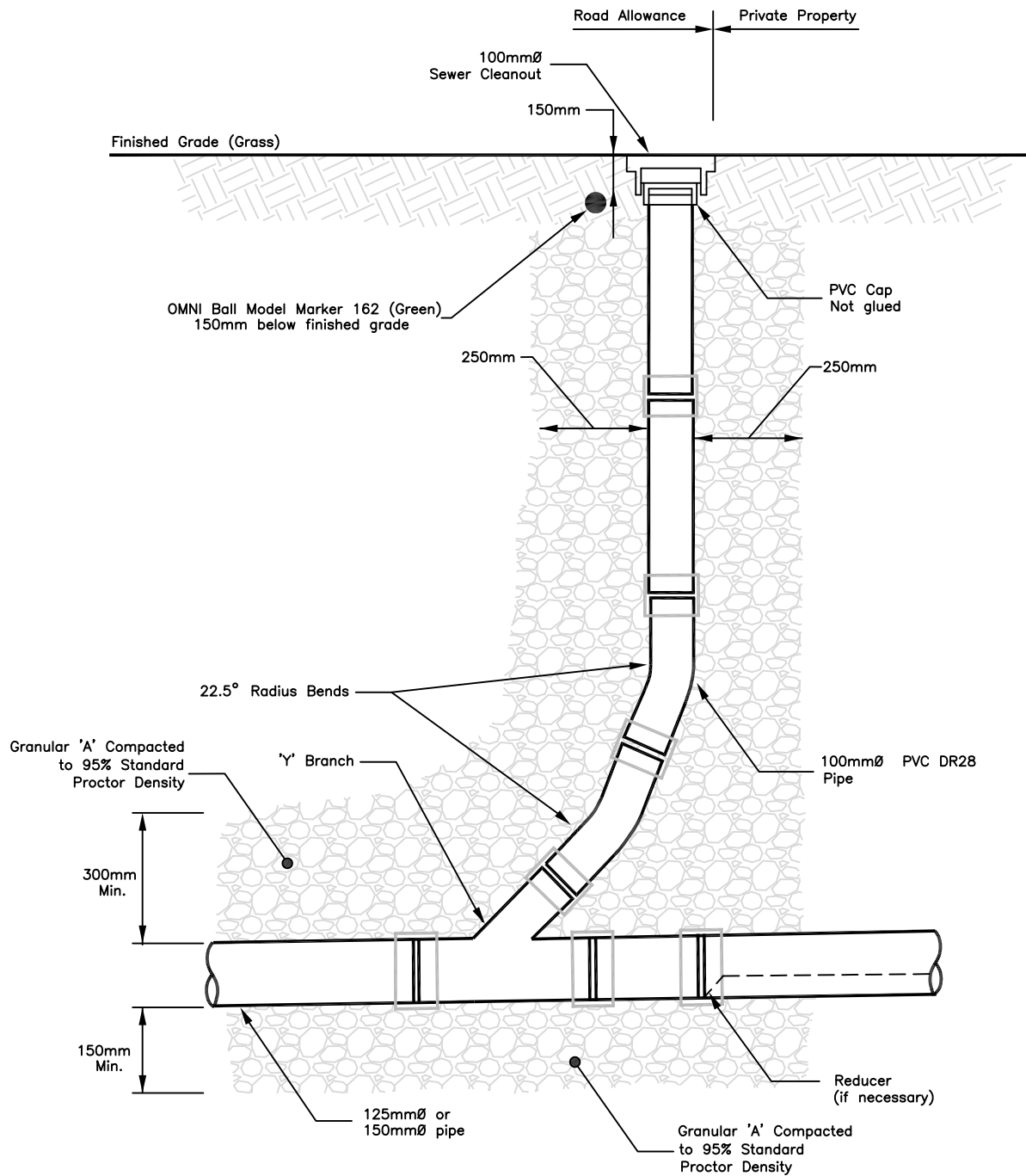

NOTE

1. Install 100mmØ surface cleanout marked "Sewer", bolted.
2. Use SIGMA VB-SC 04L (or approved equal).

**SANITARY CLEANOUT
LANDSCAPED AREAS**

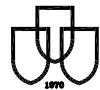

TOWN of LINCOLN
STANDARD DRAWING

DPW - 505

Rev. No.: 2 | Date: Nov. 2021

Scale: N.T.S.

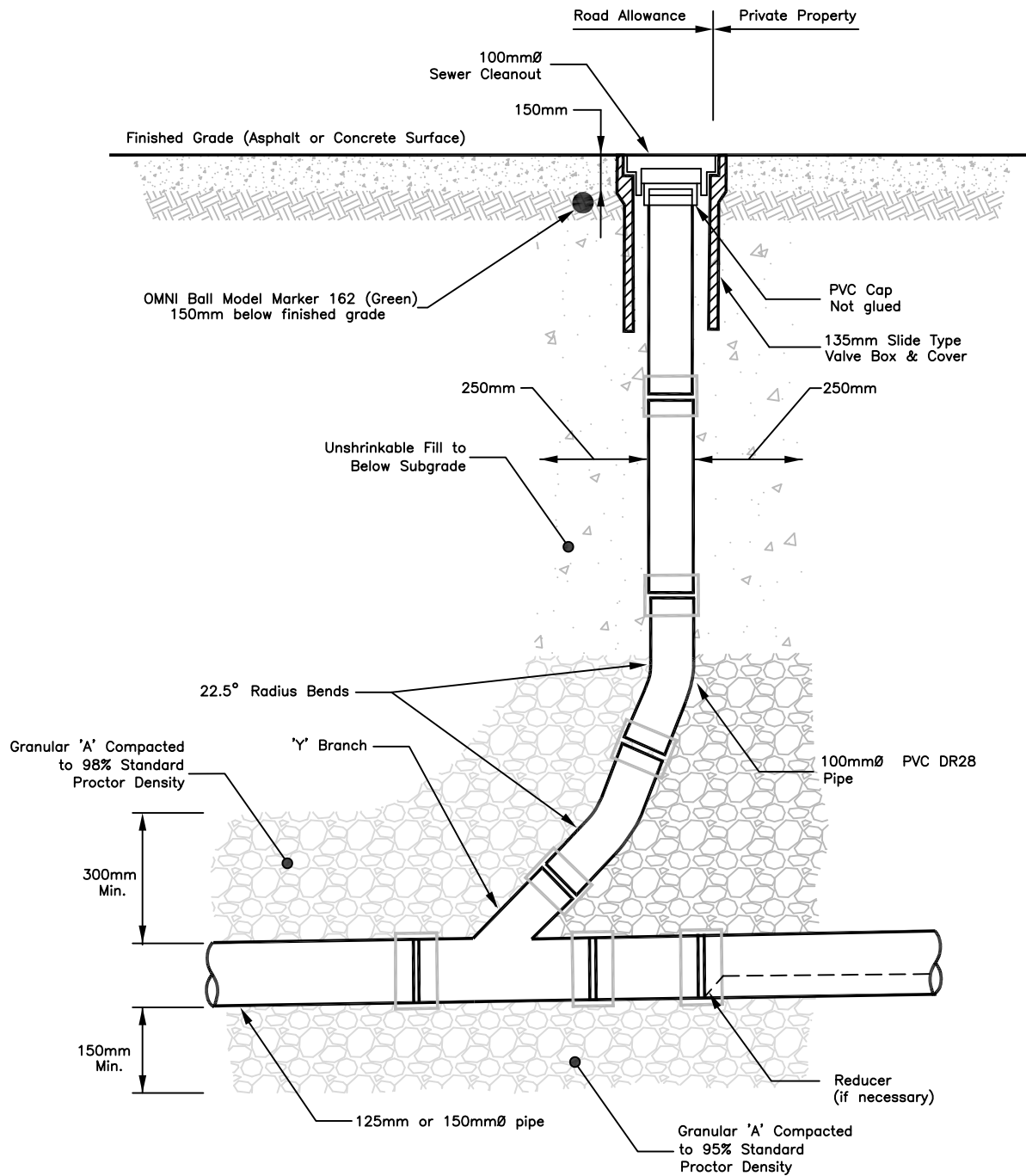

NOTE

1. Install 135mm slide type valve box and cover (marked Sewer) over PVC Cap, not glued.
2. Use East Jordan Iron Works {Product No. 85557126 with 06800006 series drop LID (or approved equal)}.
2. For use in paved areas.

SANITARY CLEANOUT HARD SURFACE AREAS



TOWN of LINCOLN
STANDARD DRAWING

DPW - 506

Rev. No.: 1	Date: Nov. 2021
Scale: N.T.S.	

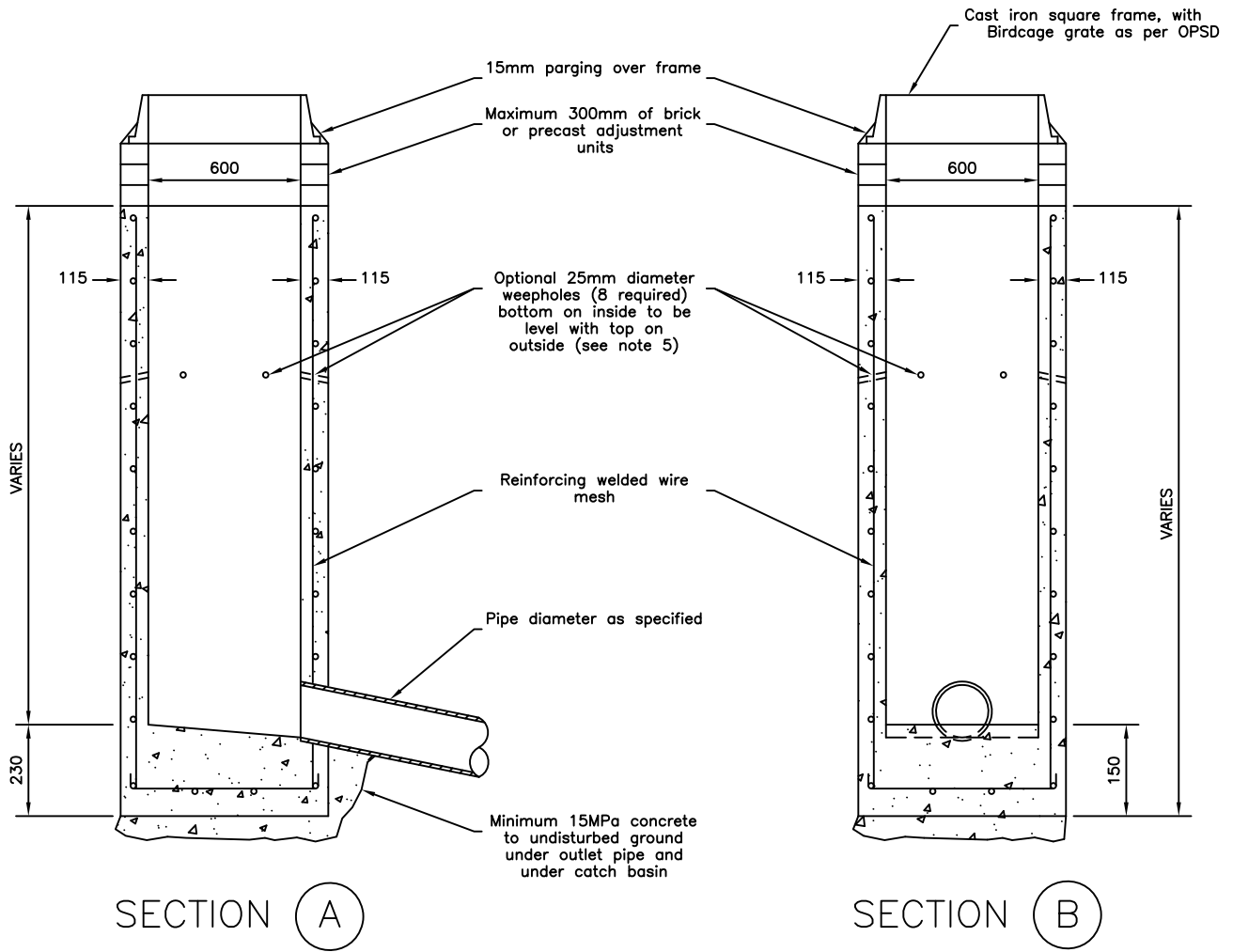

SECTION (A)

SECTION (B)

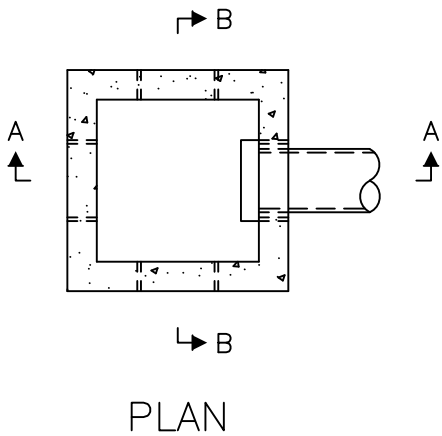

NOTES

1. Concrete shall be 32MPa at 28 Days.
2. Parging mix on all brickwork shall be 1:3 mortar mix and applied 15mm thick.
3. All joints and lifting holes shall be completely filled with a 1:3 mortar mix and pointed before backfilling.
4. Backfill shall be unshrinkable fill.
5. Where weepholes are used backfill with 50mm crushed stone in min. 300mm wedge to depth of weepholes.
6. Alternate wall thickness shall be 150mm where specified.
7. All dimensions are in millimetres unless otherwise shown.

**PRECAST REARYARD
CATCH BASIN WITHOUT
SUMP**



TOWN of LINCOLN
STANDARD DRAWING

DPW - 507

Rev. No.: 1 | Date: Feb. 2018

Scale: N.T.S.

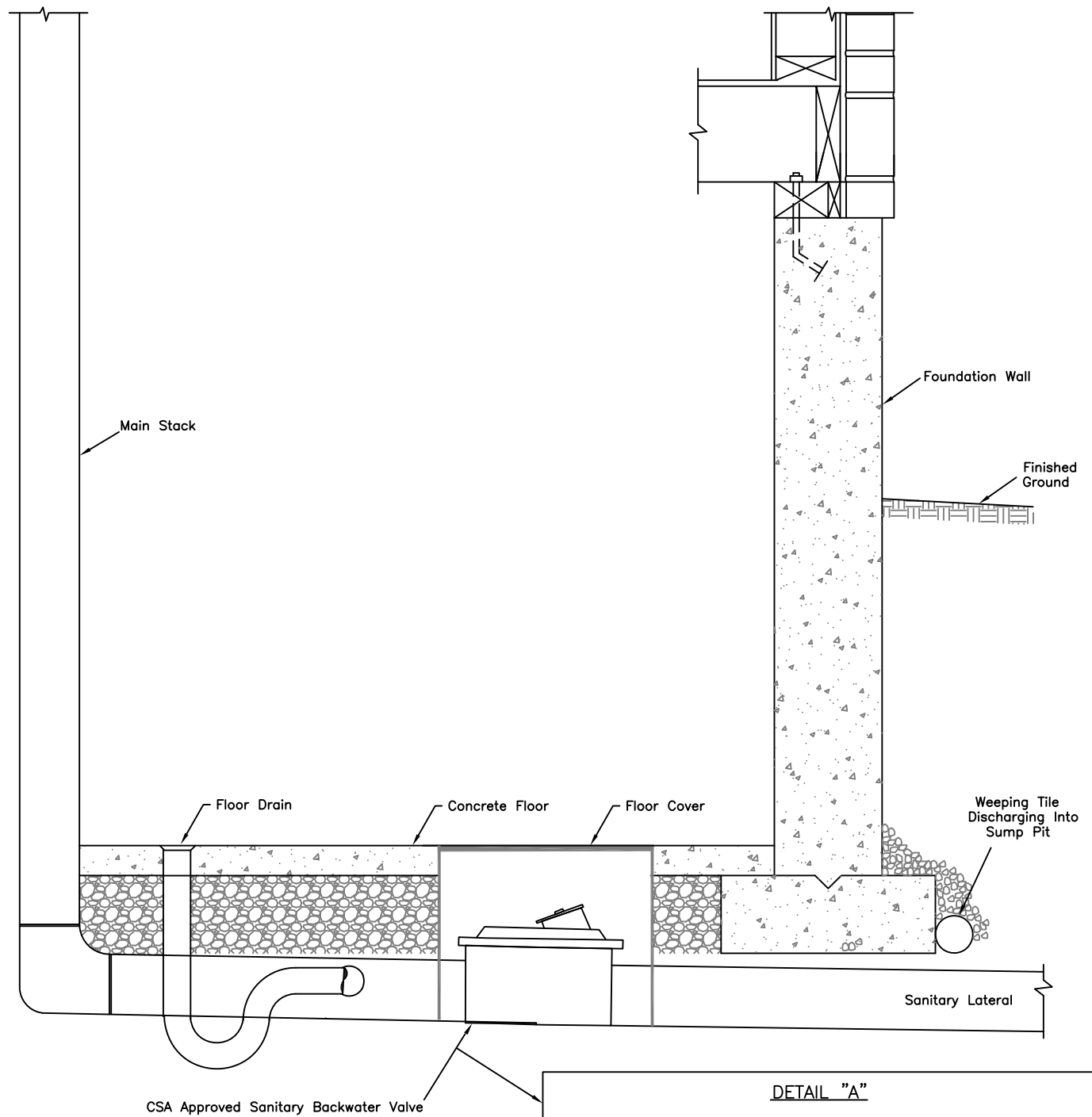

NOTES

1. The sanitary backwater valve must be CSA approved to comply with a Town of Lincoln building permit.
2. The device must be installed downstream of all branch connections.
3. Backwater valve depth may vary depending on depth of existing sanitary lateral.

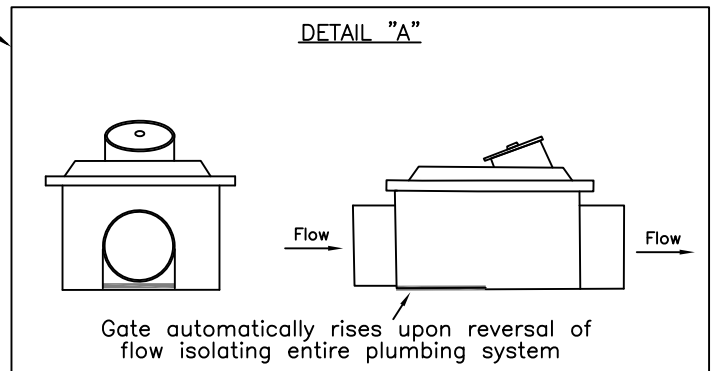

**SANITARY BACKWATER VALVE
INSTALLATION DETAIL
RESIDENTIAL LATERAL**



**TOWN of LINCOLN
STANDARD DRAWING**

DPW - 508

Rev. No.: 1 Date: Dec. 2025

Scale: N.T.S.



TOWN OF LINCOLN STANDARD DRAWINGS

Index

SERIES 600 – WATERMAINS

<u>DRAWING NO.</u>	<u>TITLE</u>
D.P.W. – 600	HYDRANT INSTALLATION
D.P.W. – 601	50mm BLOW OFF INSTALLATION
D.P.W. – 602	STANDARD WATER SERVICE INSTALLATION DETAIL FOR 20mm AND 25mm DIAMETER SIZES
D.P.W. – 603	STANDARD WATER SERVICE INSTALLATION DETAIL FOR 38mm AND 50mm DIAMETER SIZES
D.P.W. – 604	25mm FLOWMETER IN CHAMBER
D.P.W. – 605	6–8” FLOWMETER IN CHAMBER PLAN (2 PAGES)
D.P.W. – 606	GREENHOUSE WATER SERVICE INSTALLATION SCHEMATIC
D.P.W. – 607	WATER SERVICE INSTALLATION – COMMERCIAL/INDUSTRIAL
D.P.W. – 608	RESIDENTIAL WATER METER (25mm DIAMETER AND UNDER) INSTALLATION
D.P.W. – 609	TEMPORARY CONNECTION FOR PIPES 100mm DIAMETER OR LARGER
D.P.W. – 610	TEMPORARY FLUSHING/TESTING CONNECTION
D.P.W. – 611	TYPICAL INSTALL FROM WATERMAIN TO TEST TAP SAMPLING STATION
OPSD 1100.011	PIPING LAYOUT FOR BUTTERFLY AND GATE VALVES UP TO 350mm DIAMETER IN CAST-IN-PLACE CHAMBERS
OPSD 1101.010	PRECAST VALVE CHAMBER 1200mm AND 1500mm DIAMETER
OPSD 1103.010	CONCRETE THRUST BLOCKS FOR TEES, PLUGS AND HORIZONTAL BENDS
OPSD 1103.020	CONCRETE THRUST BLOCKS FOR VERTICAL BENDS
OPSD 1108.010	CAST-IN-PLACE WATER METER CHAMBER FOR 75mm TO 250mm METERS

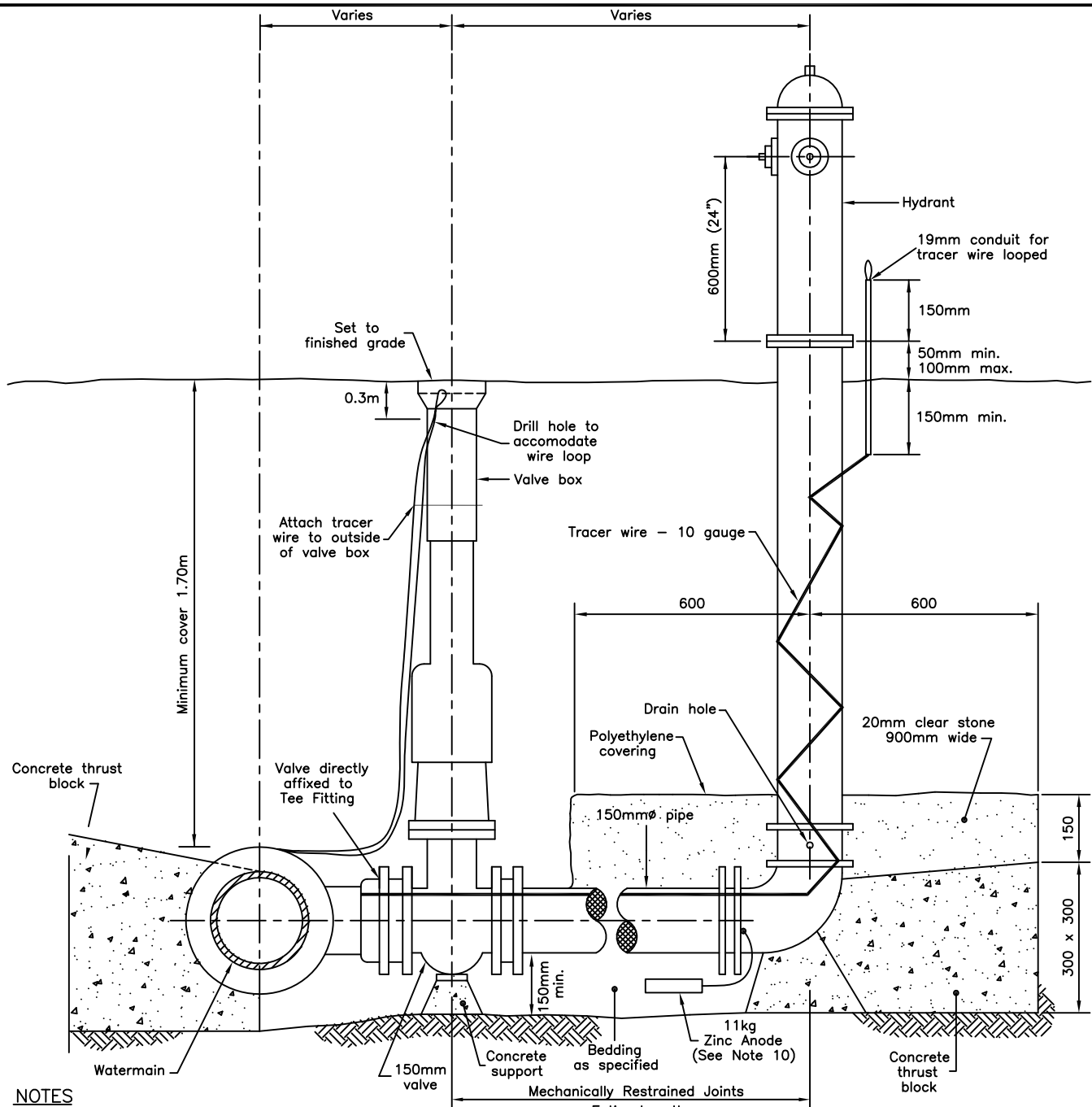

NOTES

1. All concrete to be 20MPa compressive strength, type V (sulphate resistant).
2. All concrete blocking to be poured against undisturbed soil.
3. Polyethylene bond breaker to be used between concrete and fittings.
4. All mechanical fittings to have stainless steel bolts.
5. Denso anti-corrosion protect system (meeting ISO 9001 standards) to be used on all metallic pipe, fittings, appurtenances underground. Corrosion protection must not cover drain ring on hydrant unless plugged due to high water table.
6. Hydrants to be equipped with a steamer port c/w 100mm Storz connector and two 64mm ports.
7. Hydrants to be in conformance with AWWA C502 (AVK Series 2780, Canada Valve Century B508, Clow/Brigadier M67B).
8. Hydrants to have breakaway sections at ground line.
9. Hydrant lateral must be mechanically restrained using Uni-Flange restrainers or an approved equivalent.
10. Valve boxes to be 125mm in accordance with AWWA C500, resilient seat, no rising stem for PVC pipe with stainless steel bolts.
11. Anode to be placed with 1.0m min. horizontal clearance from pipe and at same elevation. Anodes to be accordance with Town specifications.
12. All dimensions are in millimetres unless otherwise shown.

HYDRANT INSTALLATION

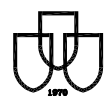

TOWN of LINCOLN
STANDARD DRAWING

DPW - 600

Rev. No.: 5 Date: Jan 2025

Scale: N.T.S.

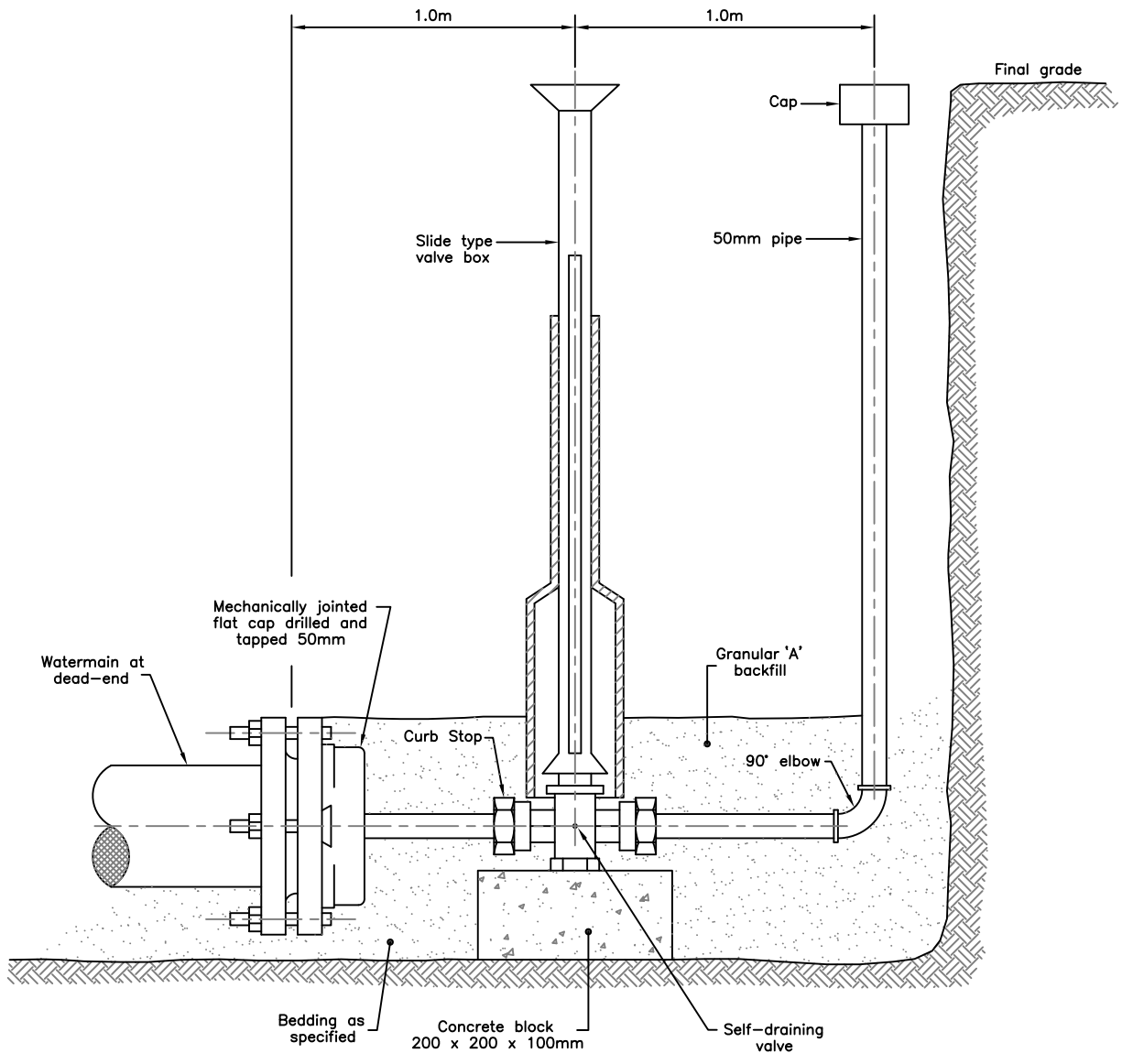

NOTES

1. All fittings to have anode protection and to be tarred.
2. Valve in accordance with AWWA C500, resilient seat, no rising stem, with stainless steel bolts.
3. Use 10 gauge tracer wire on all P.V.C. or A.C. watermains.
4. Concrete to be 20 MPa.
5. Denso anti-corrosion protection system (meeting ISO 9001 standards) to be used on all metallic pipe, fittings, appurtenances underground.
6. All dimensions are in millimetres unless otherwise shown.

50mm BLOW OFF INSTALLATION

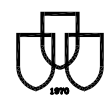

TOWN of LINCOLN
STANDARD DRAWING

DPW - 601

Rev. No.: 4 | Date: Jan. 2018

Scale: N.T.S.

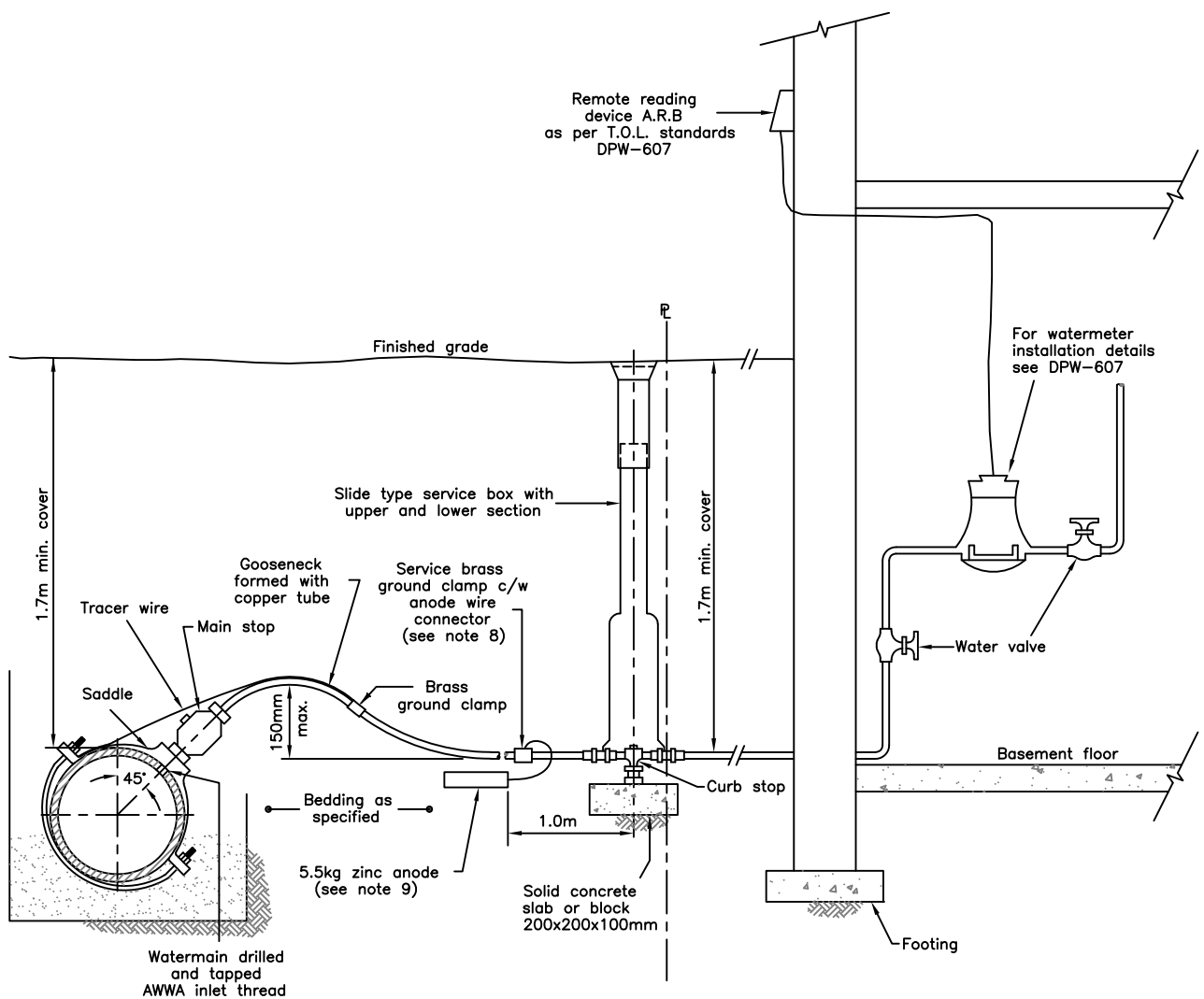

NOTES

1. Plastic pipe services are NOT permissible, except for private water service pipe.
2. All connections to be made with approved, compression-type couplings only.
3. All water services to be installed at right angles to the watermain.
4. Stainless steel saddles with double stainless steel bolts and nuts to be used on all watermains.
5. All water services to have anode protection as per Town standards.
6. Service pipe to be 760mm from inside of wall.
7. Watermeter to be installed horizontally.
8. Service brass ground clamp to be coated with T.C. mastic or wrapped with "Scotchfill" electrical putty or approved equal.
9. Anode to be placed at least 1.0m away from curb stop and as deep as the bottom of the service.
10. Service box rods shall be made of stainless steel and stainless steel cotter pin.
11. Tracer wire - 10 gauge.
12. Where non-metallic pipe is used for the private water service pipe and/or private water pipe downstream of the meter, rigid supports are required for the water service pipe and water meter to prevent movement of the piping around the meter.
13. All water meters shall be installed with a minimum 1.2m unobstructed clearance in front of the water meter to nearest wall and 300mm unobstructed clearance behind the water meter to nearest wall. Water meters shall not be installed at a height greater than 450mm above the floor (refer to DPW 607-Meter Installation).
14. The working space in front of the meter shall a minimum of 1.8m unobstructed head clearance.
15. Where non-metallic pipe is used for the private water service pipe, tracer wire shall be attached as per the latest revision of the OBC (minimum 14 gauge, with light coloured coating).
16. Where applicable, electrical grounding of building via a copper water pipe must be maintained.
17. All dimensions in mm unless otherwise noted.

WATER SERVICE INSTALLATION DETAILS FOR 20mm AND 25mm DIAMETER SIZES



TOWN of LINCOLN
STANDARD DRAWING

DPW - 602

Rev. No.: 5 Date: Nov. 2022

Scale: N.T.S.

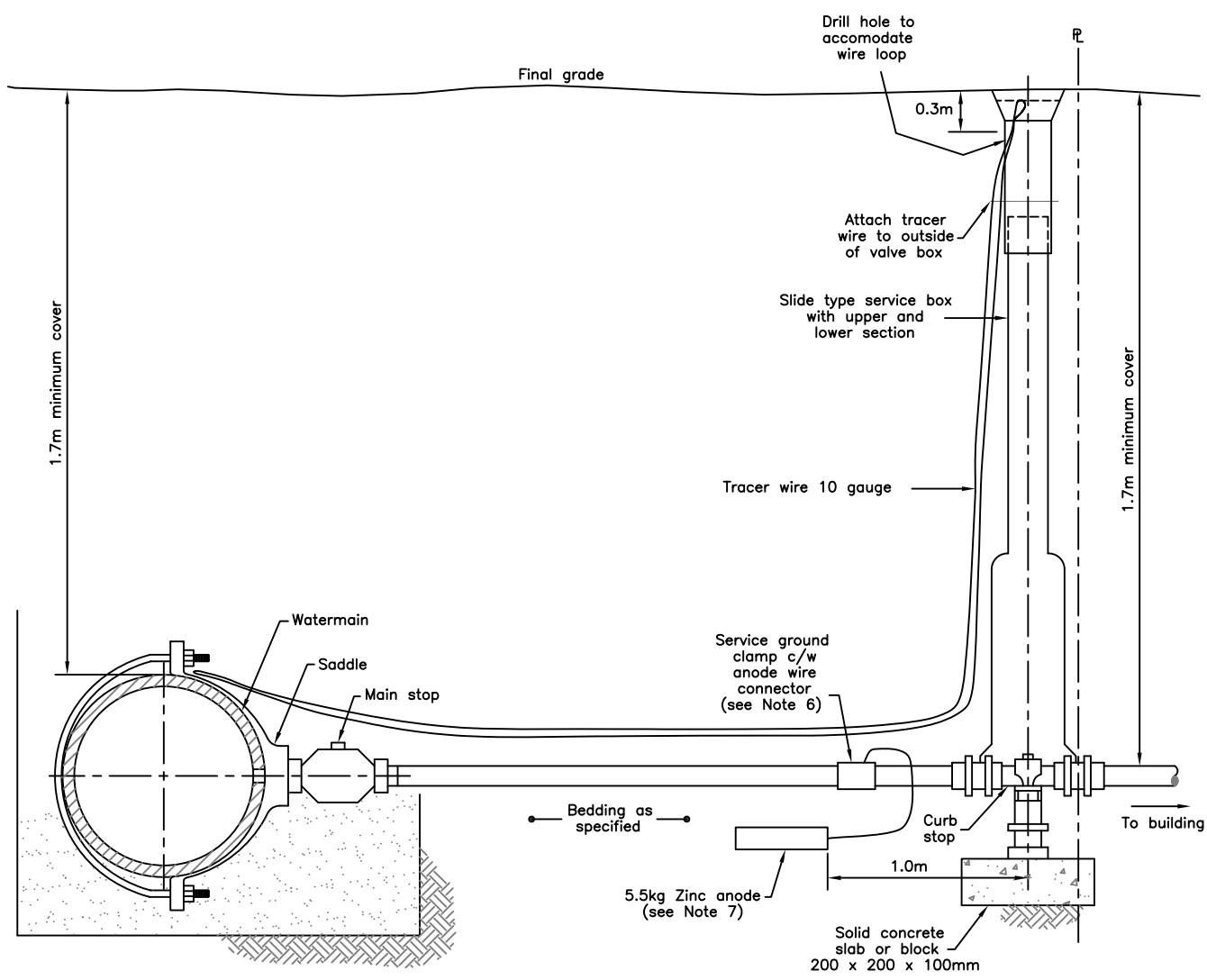

NOTES

1. Plastic pipe services are not permissible.
2. All connections to be made with approved compression-type couplings only.
3. All water services to be installed at right angles to the watermain.
4. Stainless steel saddles with double stainless steel bolts and nuts shall be used.
5. All water services to have anode protection as per Town standards.
6. Service ground clamp to be coated with T.C. mastic or wrapped with "Scotchfill" electrical putty or approved equal.
7. Anode to be placed at least 1.0m away from water service and as deep as the bottom of the service.
8. All dimensions are in millimetres unless otherwise shown.

**WATER SERVICE INSTALLATION
DETAILS FOR 38mm AND
50mm DIAMETER SIZES**



TOWN of LINCOLN
STANDARD DRAWING

DPW - 603

Rev. No.: 4 Date: Jan. 2018
Scale: N.T.S.

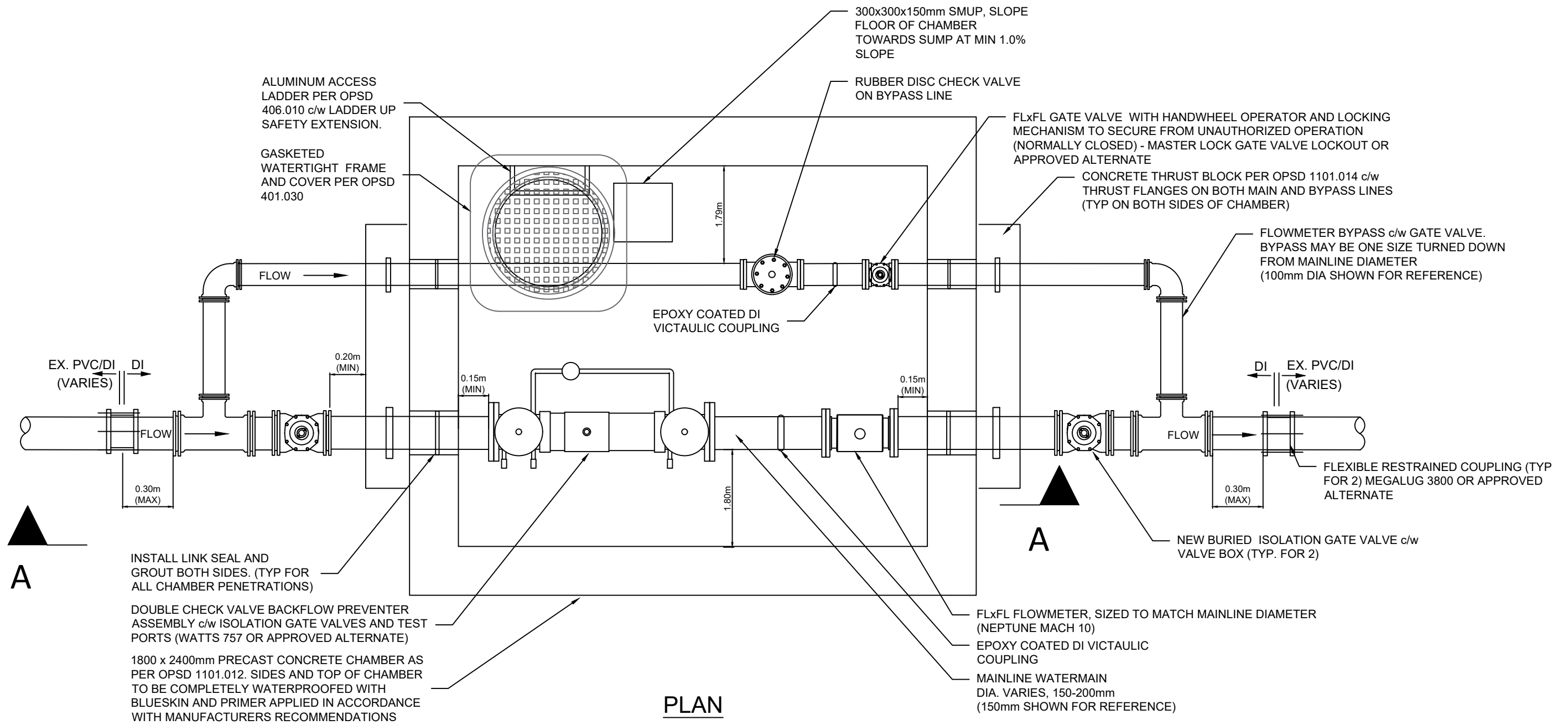

PLAN

DRAWING CREATED BY C3 WATER

6-8" FLOWMETER IN CHAMBER PLAN



TOWN of LINCOLN
STANDARD DRAWING

DPW - 605

Rev. No.: 2 Date: DEC 2023

Scale: N.T.S.

Pages:
1 OF 2

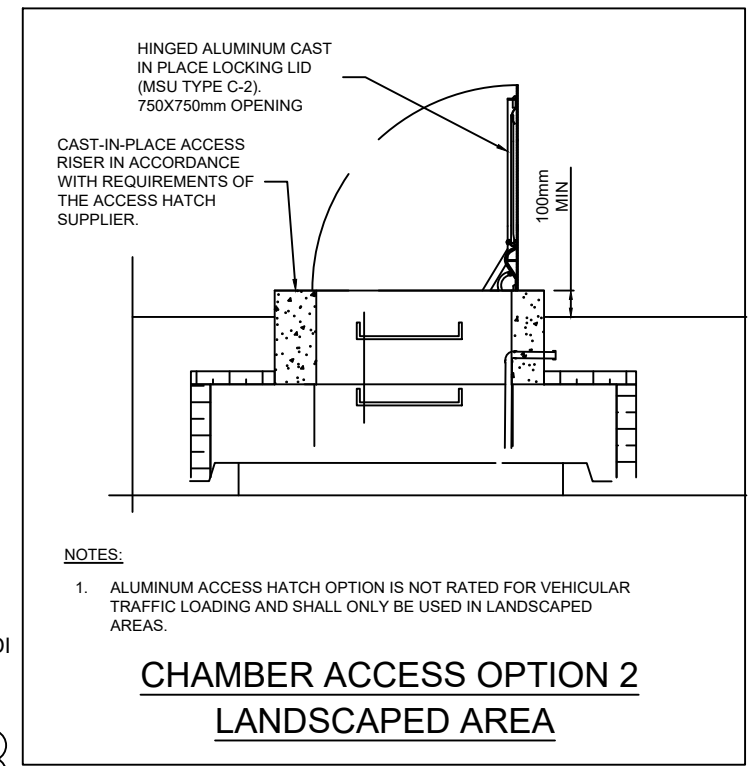
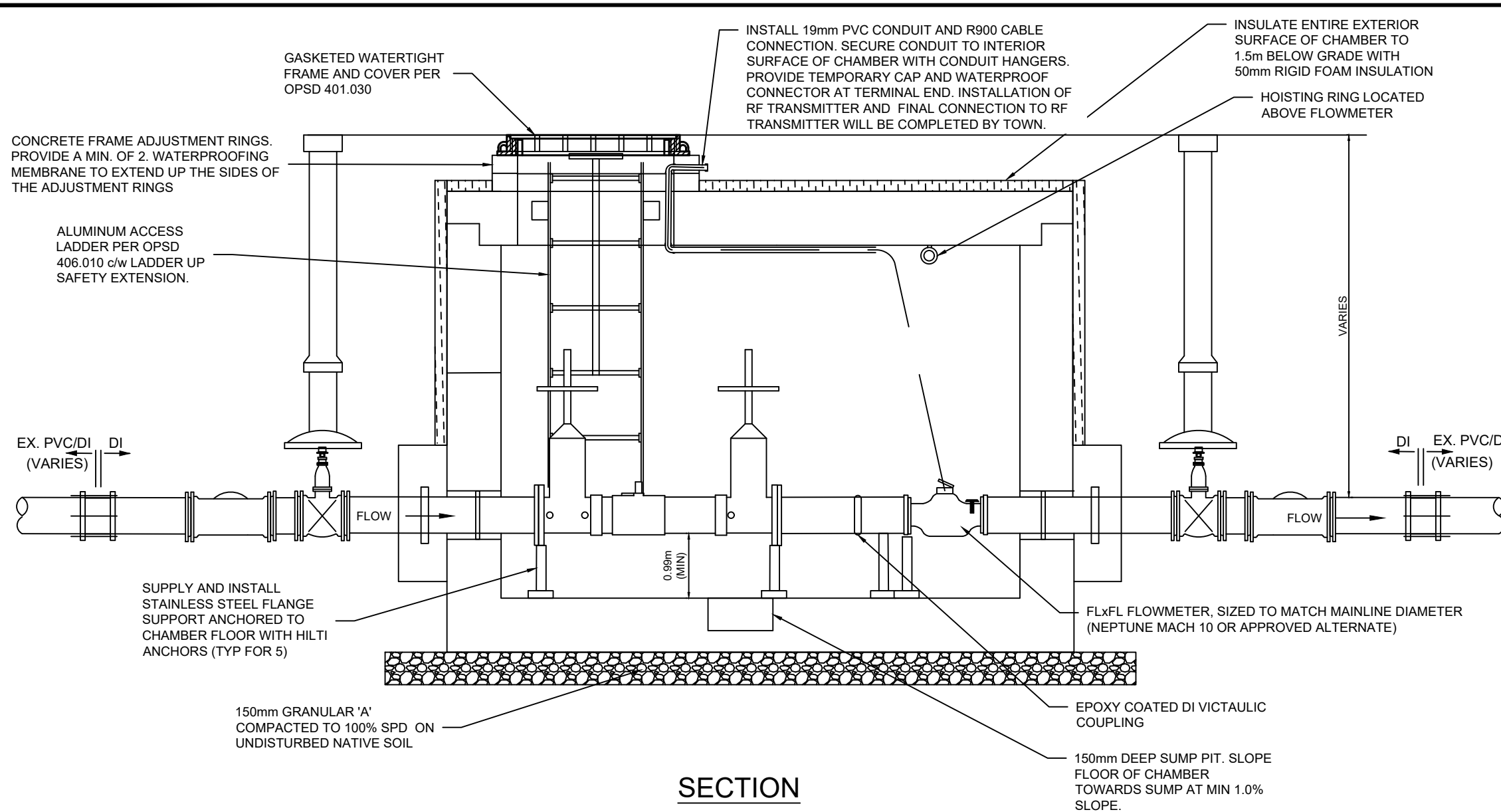

SECTION

GENERAL NOTES:

- ALL DIMENSIONS ARE IN METERS UNLESS OTHERWISE NOTED.
- DRAWINGS INDICATE MINIMUM CLEARANCES. EXACT DIMENSIONS WILL VARY DEPENDING ON MAIN LINE DIAMETER. MINIMUM CLEARANCES ARE TO BE MAINTAINED.
- TEST PORTS ON DOUBLE CHECK VALVE ARE TO BE PROTECTED WITH WATERTIGHT PLUGS
- SUPPLY, PLACE AND MAINTAIN SHEETING, BRACING AND SHORING AS REQUIRED TO SUPPORT SIDES OF EXCAVATIONS TO PREVENT MOVEMENT IN ACCORDANCE WITH THE MINISTRY OF LABOUR REQUIREMENTS.
- THE CONTRACTOR SHALL BE RESPONSIBLE FOR PROTECTION OF EXCAVATIONS WHERE REQUIRED TO PREVENT ADVERSE EFFECTS OF RAIN OR ANY OTHER WEATHER CONDITIONS ON EXPOSED EXCAVATIONS.
- THE CONTRACTOR SHALL BE RESPONSIBLE FOR DEWATERING OF ALL EXCAVATIONS.
- THE CONTRACTOR IS RESPONSIBLE FOR TEMPORARY SUPPORT AND/OR RELOCATION OF EXISTING UTILITIES AND SHALL PRESERVE/PROTECT ALL EXISTING UTILITIES DURING CONSTRUCTION. EXCAVATION IN CLOSE PROXIMITY TO EXISTING SERVICES WHICH ARE TO REMAIN SHALL BE BY HAND.
- ALL DUCTILE IRON PIPES, VALVES, AND FITTINGS SHALL BE FULLY WRAPPED IN A PETROLATUM TAPE AND MASTIC SYSTEM INSTALLED IN ACCORDANCE WITH MANUFACTURERS RECOMMENDATIONS. THIS APPLIES TO BOTH BURIED AND IN CHAMBER COMPONENTS.
- ALL FIRELINES MUST BE METERED WITH BACKFLOW. WATER USED FOR FIRE FIGHTING PURPOSES WILL NOT BE CHARGED.
- EXISTING TREES AND SHRUBS WHICH ARE NOT TO BE REMOVED SHALL BE PROTECTED DURING ALL PHASES OF CONSTRUCTION.
- ALL TOPSOIL SHALL BE STOCKPILED SEPARATELY FROM OTHER EXCAVATED MATERIAL BY THE CONTRACTOR. UNDER NO CIRCUMSTANCES SHALL THE CONTRACTOR USE TOPSOIL FROM ANY SOURCE AS BACKFILL IN A TRENCH.
- ALL AREAS DISTURBED BY CONSTRUCTION SHALL BE RESTORED TO ORIGINAL CONDITIONS OR BETTER. GRASS AREA DISTURBED TO BE RESTORED WITH MINIMUM 150mm TOPSOIL AND SOD.
- ALL ROAD SURFACES DISTURBED BY CONSTRUCTION SHALL BE REINSTATED AS PER THE TOWN OF LINCOLN MINIMUM ASPHALT RESTORATION REQUIREMENTS.
- CHAMBER LOCATION SHALL BE SUBJECT TO APPROVAL BY THE TOWN. WHERE SITE CONDITIONS PERMIT, CHAMBER LOCATION SHALL BE SELECTED TO FALL OUTSIDE THE TRAVELED PORTION OF ROADWAYS.

- ACCESS OPTION 2 SHALL BE USED FOR ALL CHAMBER LOCATIONS WITHIN LANDSCAPED AREAS. ACCESS OPTION 2 IS NOT SUITABLE FOR TRAFFIC LOADING AND SHALL NOT BE USED IN AREAS WITH REGULAR VEHICULAR LOADING.
- OWNER IS RESPONSIBLE FOR THE REGULAR MAINTENANCE AND TESTING OF THE BACK FLOW PREVENTION DEVICE. AT A MINIMUM, ANNUAL TESTING SHALL BE PERFORMED BY A LICENSED PLUMBER WITH A COPY OF THE TEST REPORT FORWARDED TO THE TOWN.

EQUIPMENT

- 6-8" (150-200mm) METERS: NEPTUNE MACH10
- DOUBLE BACKFLOW PREVENTION DEVICE: WATTS 757 (MAINLINE)
- RUBBER FLAP DISC CHECK VALVE: VAL-MATIC SWING-FLEX w/ BACKFLOW ACTUATOR
- BYPASS GATE VALVE SECURING DEVICE: MASTER LOCK GATE VALVE LOCKOUT, OR APPROVED ALTERNATE
- ALL OTHER VALVES, FITTINGS, PIPE, AND ADAPTERS SHALL BE AS PER THE TOWN OF LINCOLN MUNICIPAL DESIGN STANDARDS.

DRAWING CREATED BY C3 WATER

 <p>TOWN of LINCOLN STANDARD DRAWING</p>	Rev. No.: 2	Date: DEC 2023	Pages:
	DPW - 605	Scale: N.T.S.	2 OF 2

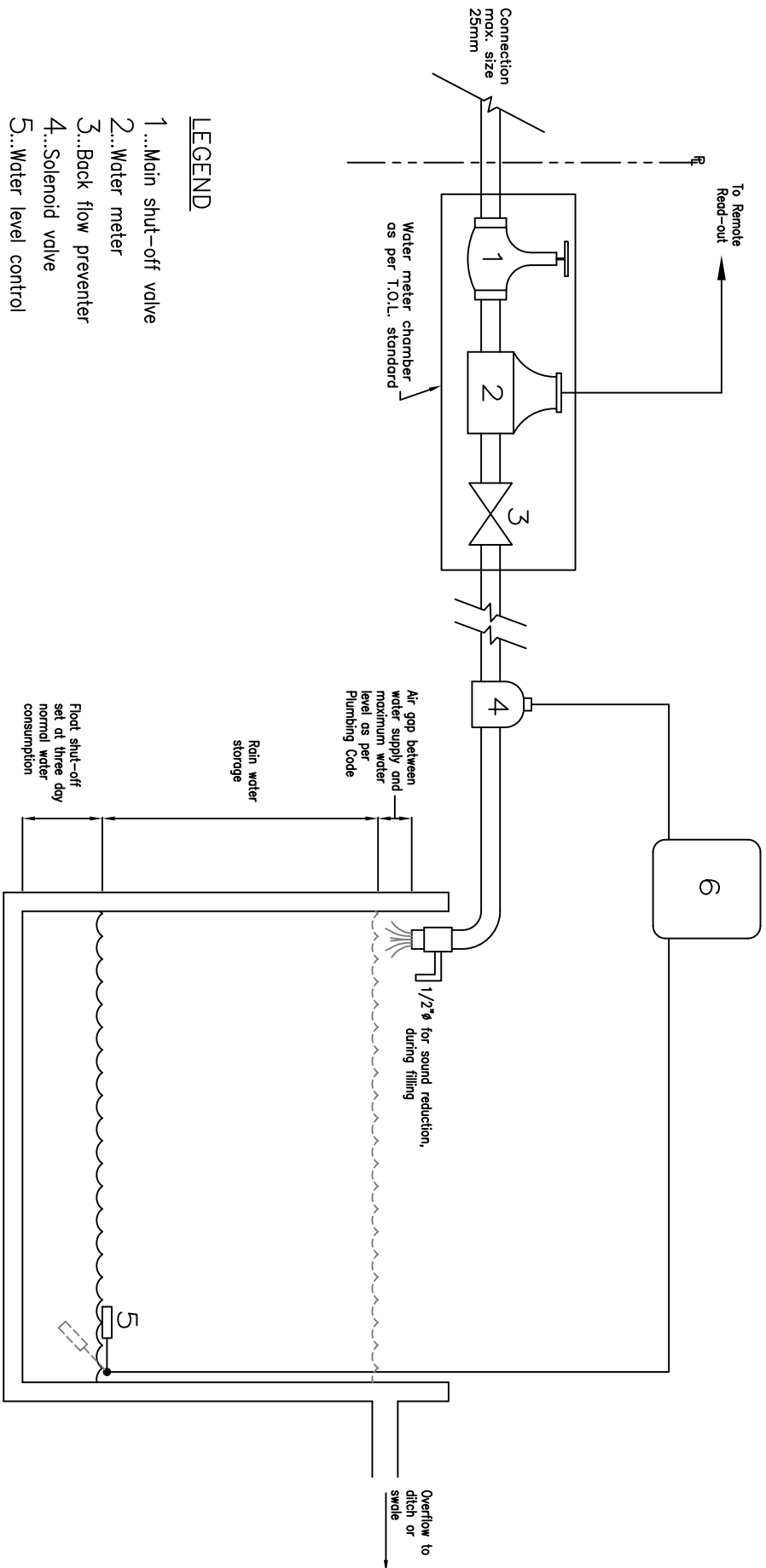

LEGEND

- 1..Main shut-off valve
- 2..Water meter
- 3..Back flow preventer
- 4..Solenoid valve
- 5..Water level control
- 6...24 hour time clock

NOTES

- 1. Meter chamber, shut-off valve, meter and back flow preventer as per Town standards.

**GREENHOUSE WATER
SERVICE INSTALLATION
SCHEMATIC**



**TOWN of LINCOLN
STANDARD DRAWING**

DPW - 606

Rev. No.: 1 | Date: June 2000
Scale: N.T.S.

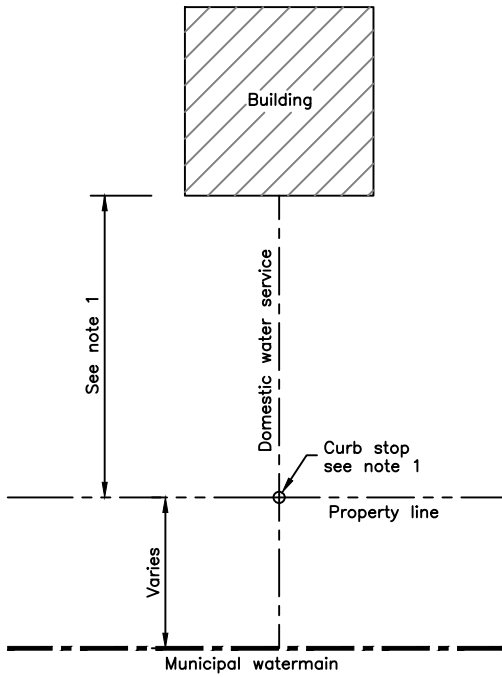

OPTION 'A'
NO HYDRANT REQUIRED

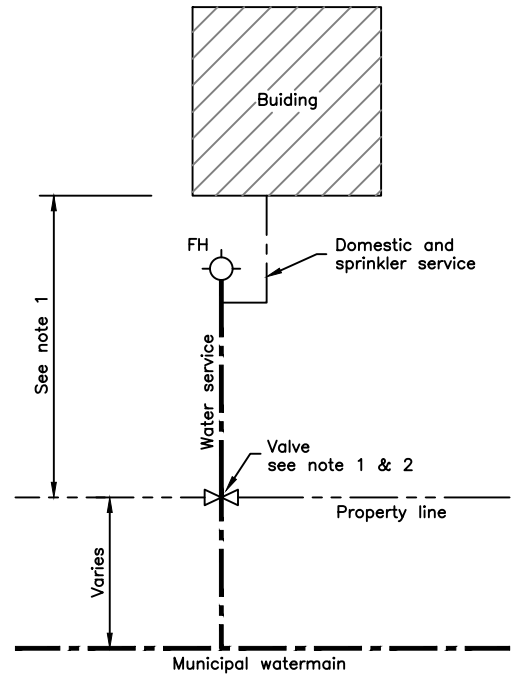

OPTION 'B'
HYDRANT REQUIRED

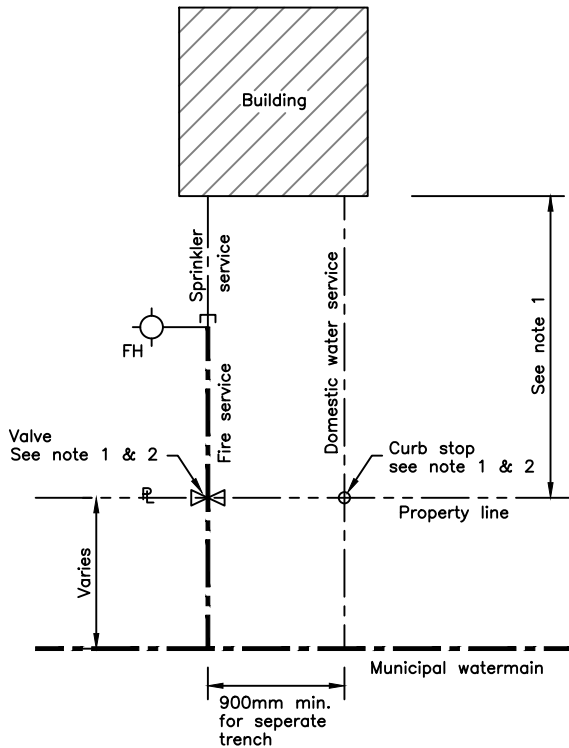

OPTION 'C'
HYDRANT REQUIRED

NOTES:

1. Meter chamber complete with meter, backflow and shut-off valve is required at property line for all firelines.
2. All private firelines shall be metered as per our guidelines.
3. See section 6 of the municipal design standards for details on service requirement and series 600 of the town standard drawings for related requirements.

**WATER SERVICE INTALLATION
COMMERCIAL/INDUSTRIAL**



**TOWN of LINCOLN
STANDARD DRAWING**

DPW - 607

Rev. No.: 2 Date: Dec 2023

Scale: N.T.S.

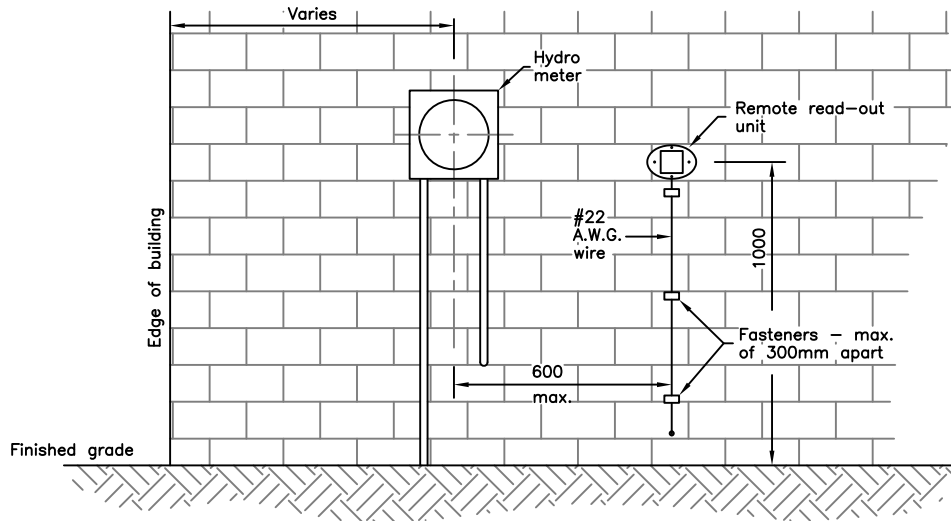

NOTE:

The water meter remote read-out may be installed on either side of hydro meter.

FRONT VIEW
(OUTSIDE)

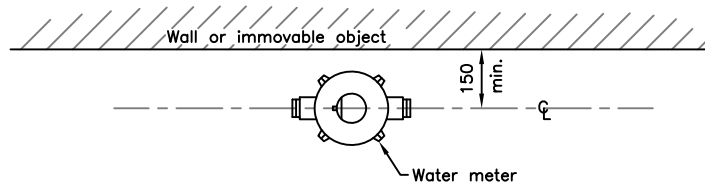

TOP VIEW
(INSIDE)

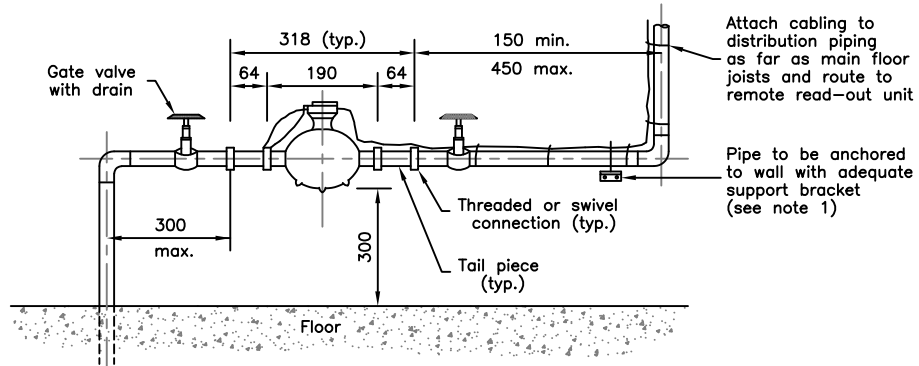

NOTES:

1. Water service pipe from the outlet side of the meter to the ceiling must be fastened to the walls at 600mm intervals.
2. All dimensions are in millimeters unless otherwise shown.

FRONT VIEW
(INSIDE)

**RESIDENTIAL WATER METER
(25mm DIAMETER AND UNDER)
INSTALLATION**



**TOWN of LINCOLN
STANDARD DRAWING**

DPW - 608

Rev. No.: 2 | Date: July 2003

Scale: N.T.S.

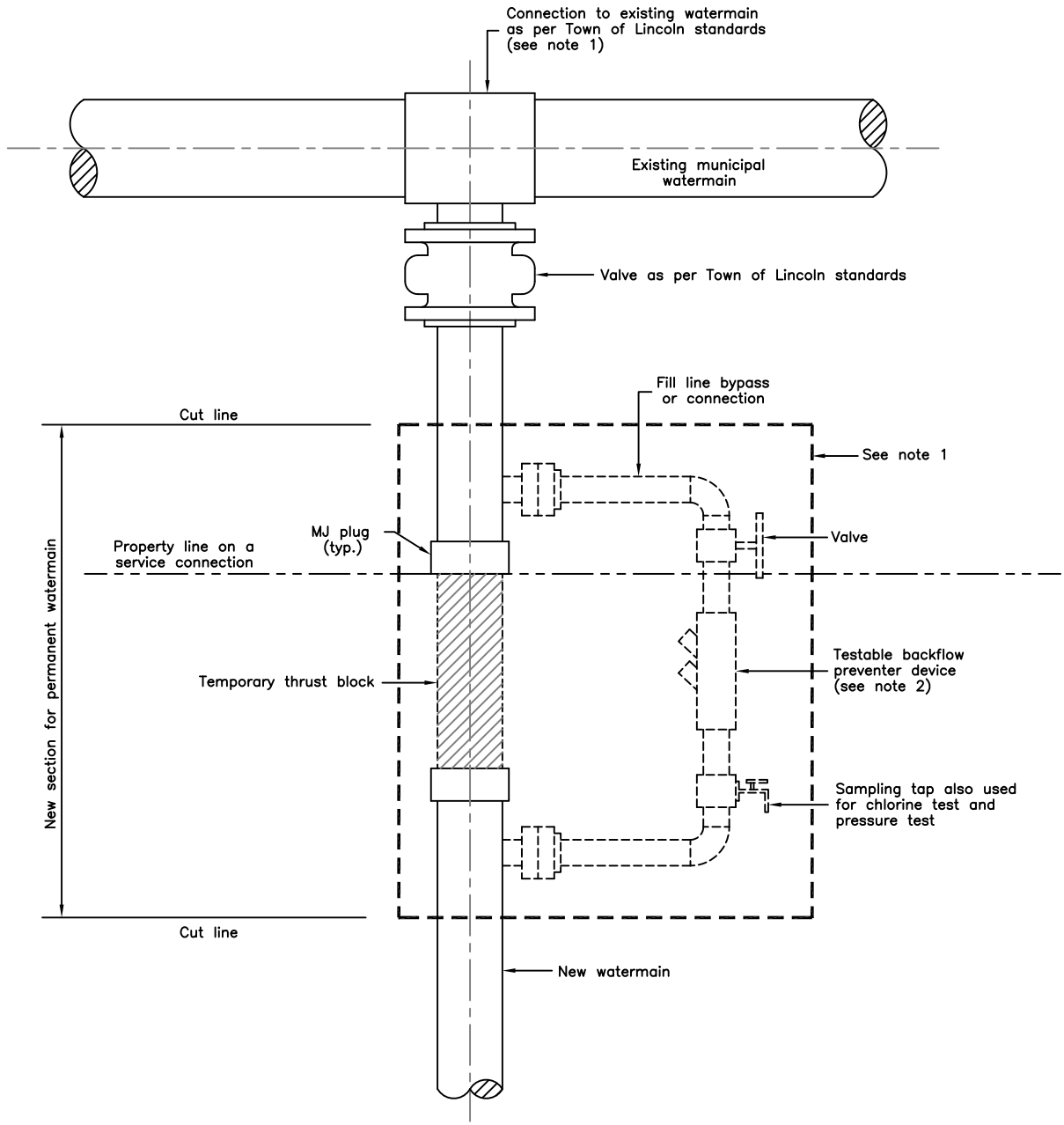

NOTES

1. Connection to municipal main to be done under supervision of licenced Town of Lincoln operator only.
2. Double check valve to be used below grade. Assembly to be removed during pressure test of new line. Double check valve with blow-off to atmosphere to be used above grade.
3. All temporary appurtenances (within dashed area) to be removed once biological testing has been approved by accredited lab facility.

**TEMPORARY CONNECTION
FOR PIPES
100mm DIAMETER OR LARGER**



TOWN of LINCOLN
STANDARD DRAWING

DPW - 609

Rev. No.: 2 | Date: June 2003

Scale: N.T.S.

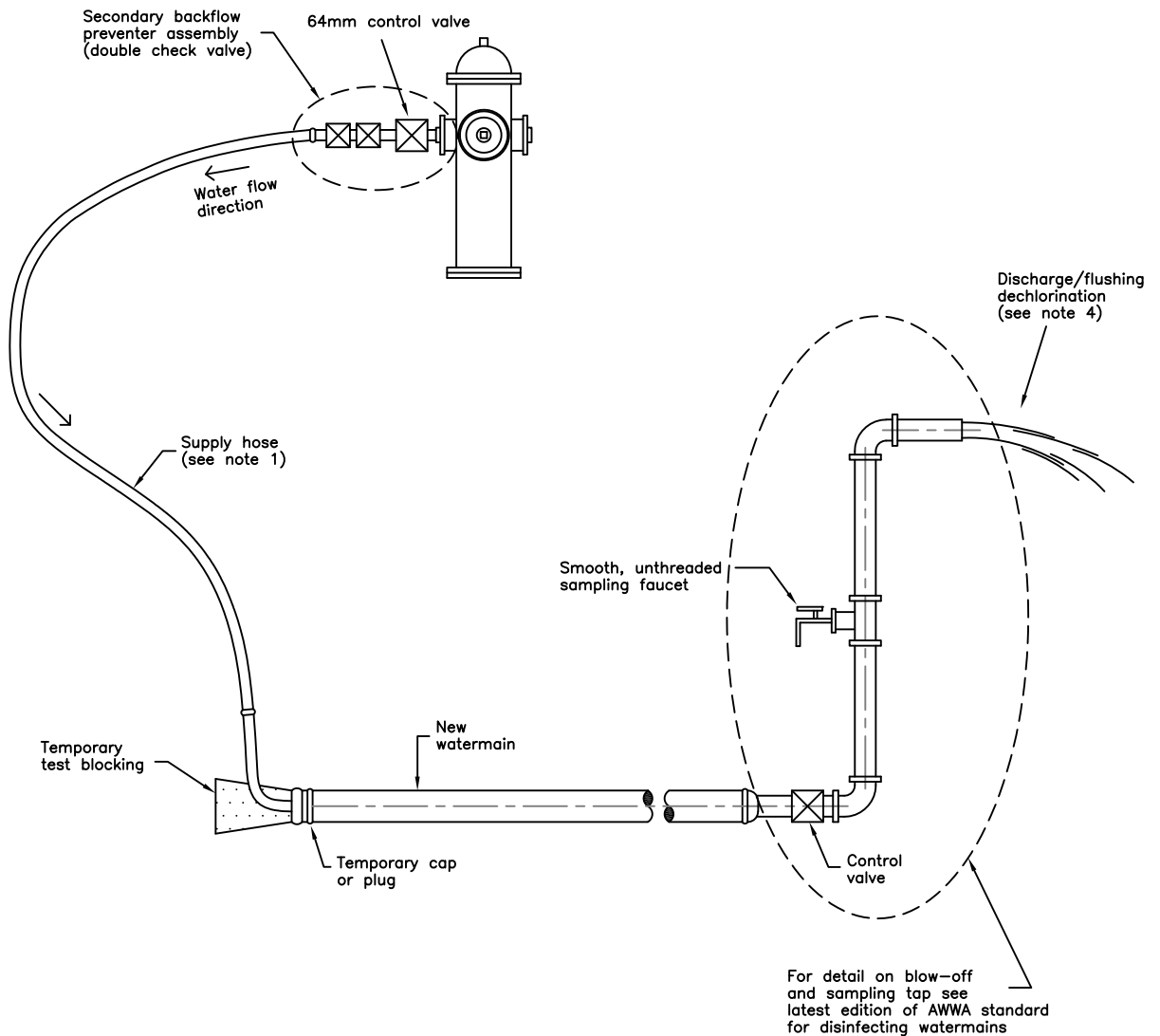

NOTES

1. Clean potable-water hose (food-grade) only. This hose is to be removed prior to the hydrostatic pressure test.
2. Double check valve assembly to be installed by licenced Town of Lincoln operators only.
3. Location and use of hydrant to be determined by Town of Lincoln.
4. Prior to disposal into the environment, an approved neutralizing chemical shall be applied to all chlorinated water used for disinfecting, testing or flushing.

**TEMPORARY
FLUSHING/TESTING
CONNECTION**



TOWN of LINCOLN
STANDARD DRAWING

DPW - 610

Rev. No.: 1 | Date: Mar. 2005

Scale: N.T.S.

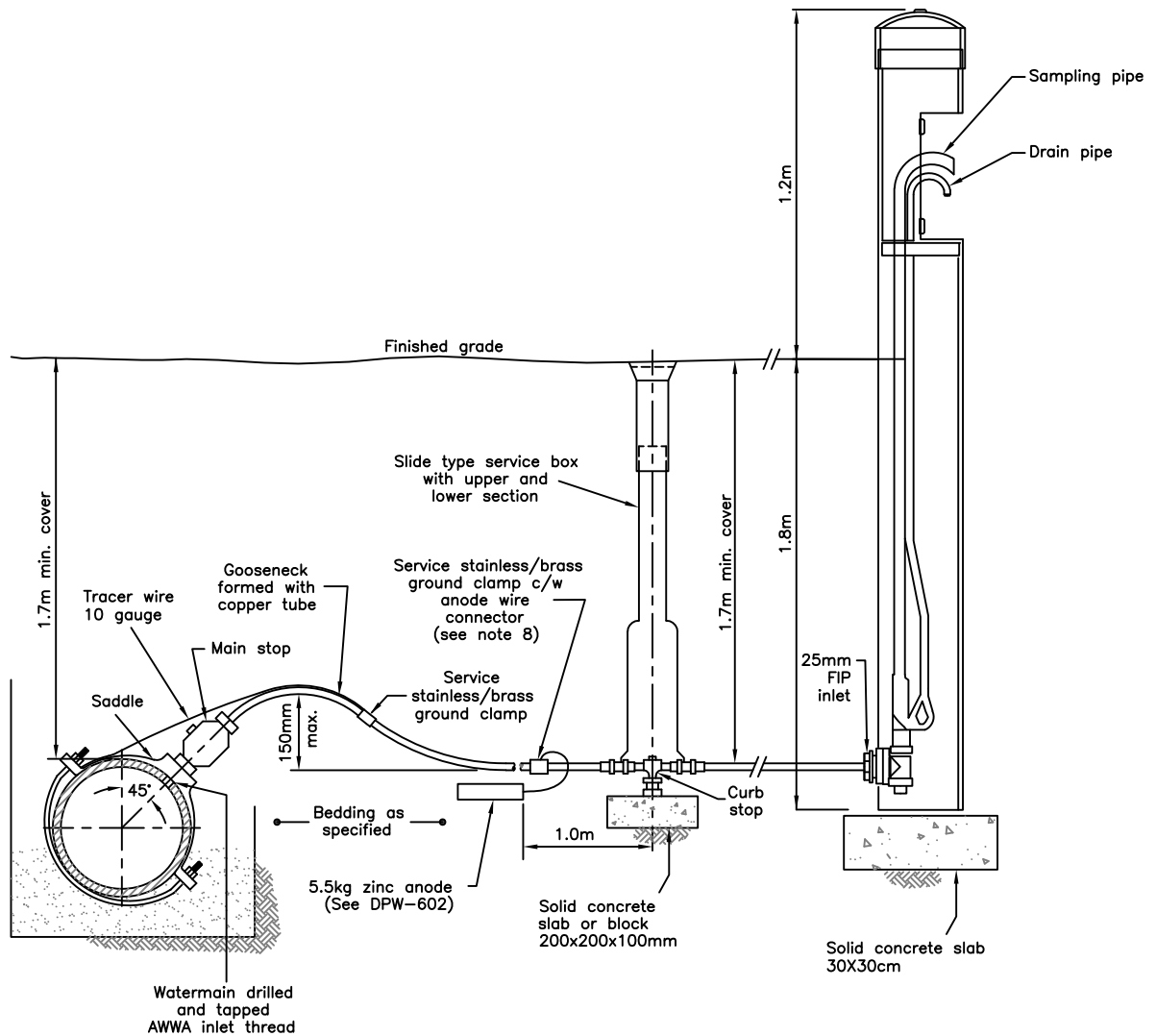

NOTES

1. Sampling stations shall have a 20mm 316 stainless steel waterway. (No lead)
2. Sampling stations shall be equipped with 9.5mm 316 stainless steel vent tube. This is used to pump standing water from unit after use, preventing freezing and bacteria growth.
3. The enclosure shall be made from plastic pipe with a lockable access door.
4. The enclosure shall protect all components from corrosive soil and ground water.
5. After the water is turned off at the curbstop, all working parts shall be removable without digging or the use of any tools.
6. Sampling stations will be equipped with a 25mm FIP inlet for the connection to the watermain.
7. Standard Test Tap is designed for a 1.8 meter bury and 1.2 meter pedestal.
8. The Test Tap to rest of a concrete slab 30cm X 30cm.
9. Curb stop to rest of a concrete slab as per DPW 602.
10. All components are to be lead free to meet NSF 61 standard.
11. Flexible tubing must be used to install the Test Tap. (No rigid pipe)
12. Ensure service tubing to the Test Tap is well supported to prevent excess pressure on the pitless adapter.
13. Backfill must be slow and consistent to prevent the deformation of the Test Tap enclosure.
14. Backfill material should be free of rocks etc. (Sand is preferred material)

TYPICAL INSTALL FROM WATERMAIN TO TEST TAP SAMPLING STATION



TOWN of LINCOLN
STANDARD DRAWING

DPW - 611

Rev. No.: 2 | Date: Jan. 2018

Scale: N.T.S.

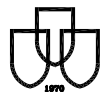

TOWN OF LINCOLN STANDARD DRAWINGS

Index

SERIES 700 - MISCELLANEOUS

<u>DRAWING NO.</u>	<u>TITLE</u>
D.P.W. – 700	DEAD END BARRICADE
D.P.W. – 701	STANDARD BOARD ON BOARD FENCE DETAIL
D.P.W. – 702	STANDARD CHAIN LINK FENCE DETAIL
D.P.W. – 703	LIGHTING ASSEMBLY CONVENTIONAL INSTALLATION
D.P.W. – 703A	LIGHTING ASSEMBLY CONVENTIONAL EQUIPMENT LIST
D.P.W. – 704	LIGHTING ASSEMBLY DECORATIVE INSTALLATION
D.P.W. – 704A	LIGHTING ASSEMBLY DECORATIVE EQUIPMENT LIST
D.P.W. – 705	DUCT TERMINATION AT EMBEDDED CONCRETE POLES
D.P.W. – 706	LIGHTING ASSEMBLY DECORATIVE (TYPE 3) INSTALLATION
D.P.W. – 706A	LIGHTING ASSEMBLY DECORATIVE (TYPE 3) EQUIPMENT LIST
D.P.W. – 707	WARNING & REGULATORY SIGNS AND STREET NAME SIGN INSTALLATION
D.P.W. – 708	DECIDUOUS TREE PLANTING 40mm, 50mm, 60mm CALLIPER
D.P.W. – 709	TREE PROTECTION FENCING
D.P.W. – 710	TYPICAL PREFABRICATED TRENCH PROTECTION ARRANGEMENT
D.P.W. – 711	STANDARD BENCH
D.P.W. – 712	TYPICAL NOISE WALL LAYOUT
D.P.W. – 713	TYPICAL UTILITY SUPPORT
D.P.W. – 714	TOURIST DIRECTIONAL SIGN INSTALLATION
D.P.W. – 715	RURAL MAIL BOX
D.P.W. – 716	ASPHALT SPEED HUMP (8.5M URBAN LOCAL ROAD)
D.P.W. – 717	ASPHALT SPEED CUSHIONS (8.5M URBAN COLLECTOR ROAD)

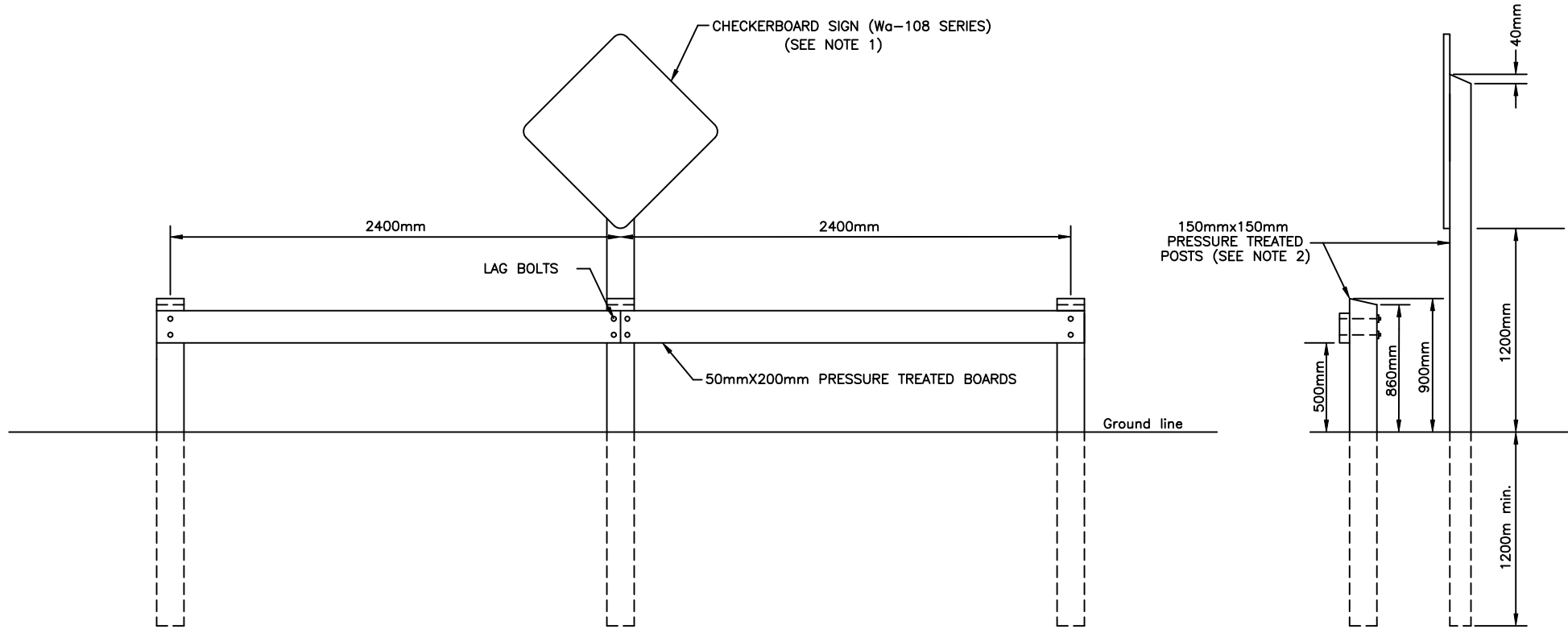

ELEVATION

SECTION

NOTES

1. CHECKERBOARD SIGN PER ONTARIO TRAFFIC MANUAL (OTM) BOOK 6
2. POSTS TO BE BREAKAWAY PER OPSD 985.110 AND TO BE SET BACK A MINIMUM OF 3.0 m FROM THE EDGE OF TRAVELLED WAY
3. STOP AHEAD (Wb-1 SERIES) AND NO EXIT (WA-31) SIGNS TO BE INSTALLED WHERE APPROPRIATE PER ONTARIO TRAFFIC MANUAL (OTM) BOOK 6
4. SOLAR-POWERED FLASHING BEACONS MAY BE REQUIRED TO SUPPLEMENT SIGNAGE IN LOCATIONS WITH HIGH SPEEDS, LIMITED VISIBILITY, OR A HISTORY OF COLLISIONS

DEAD END BARRICADE



TOWN of LINCOLN
STANDARD DRAWING

DPW - 700

Rev. No.: 3 | Date: Sept 2025

Scale: N.T.S.

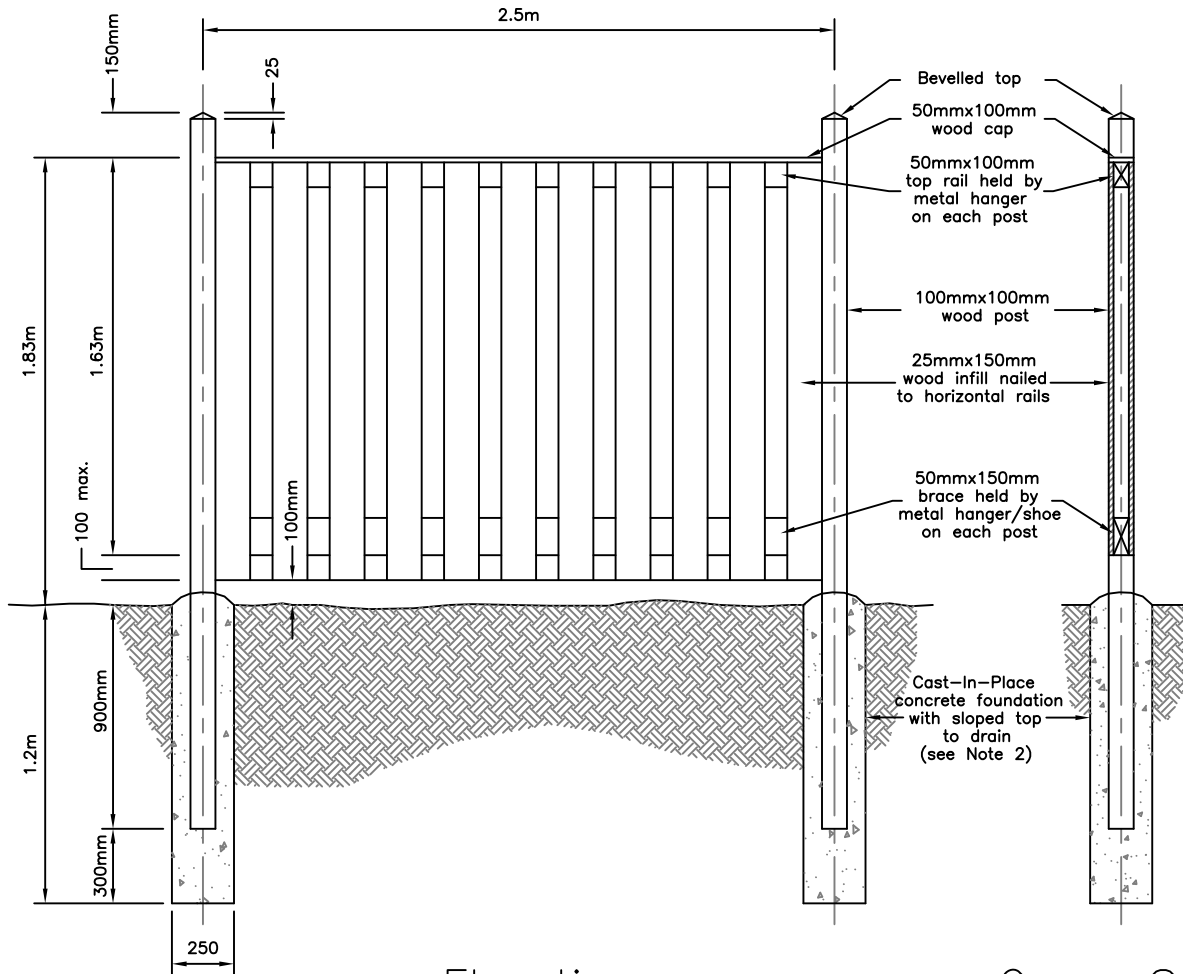
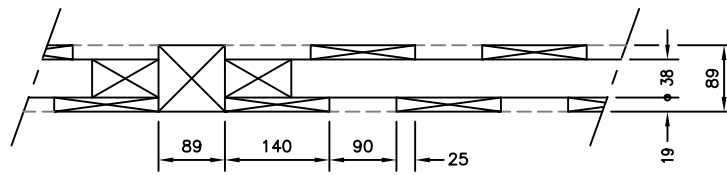

NOTES:

1. Only dipped galvanized nails to be used.
2. Concrete to be 20 MPa compressive strength and to be poured against undisturbed ground.
3. All dimensions are in millimetres unless otherwise shown.

STANDARD BOARD ON BOARD FENCE DETAIL



**TOWN of LINCOLN
STANDARD DRAWING**

DPW - 701

Rev. No.: 2 Date: May 1999

Scale: N.T.S.

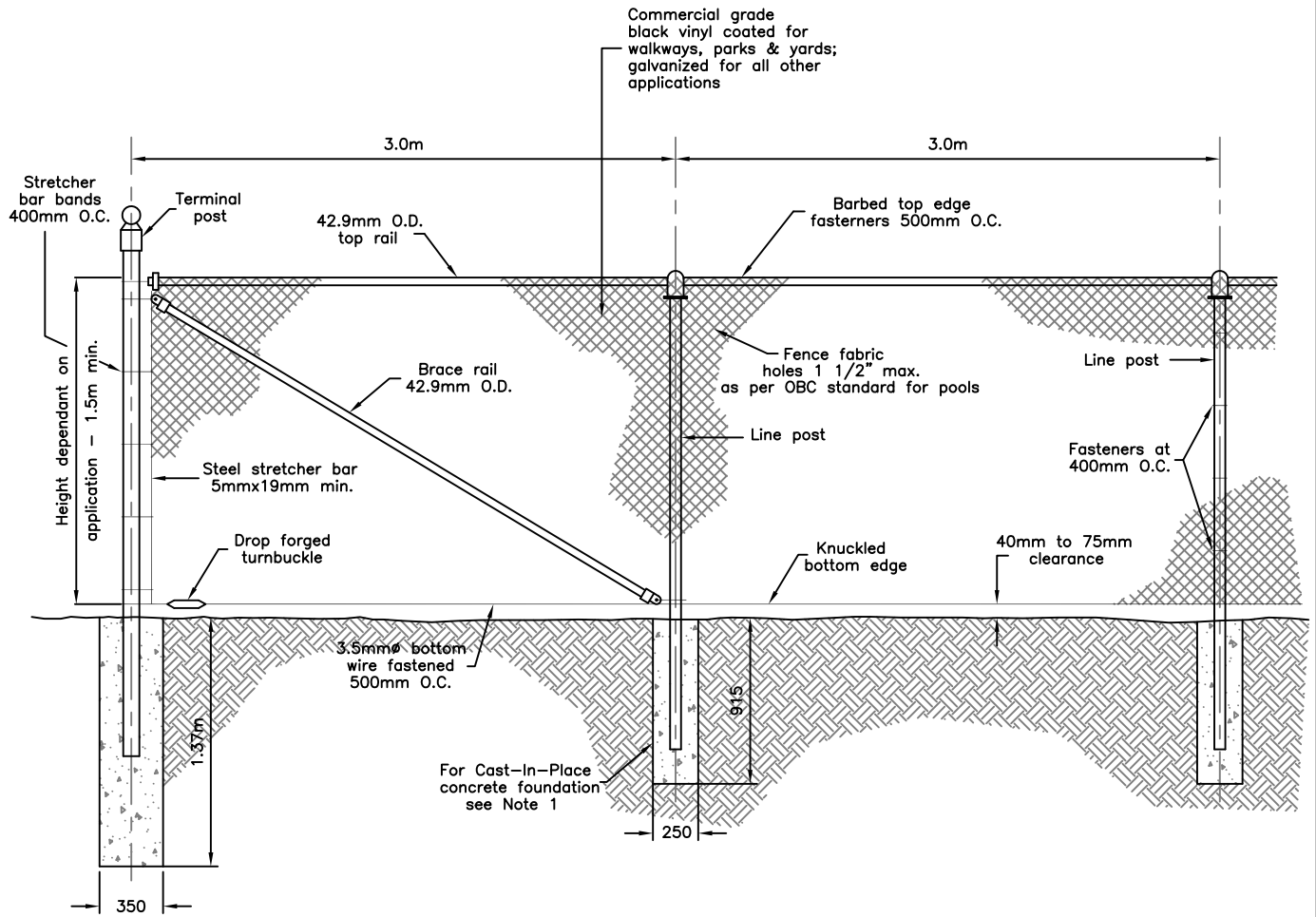

POST DETAILS				
Post Type	O.D. (mm)	Post Length		Sleeves O.D. (mm)
		Standard (m)	Retaining walls (m)	
Line post	60.3	2.60	2.0	88.9
End, corner, or straining post	88.9	2.90	2.3	114.3

NOTES:

1. Concrete to be 20 MPa compressive strength. and to be poured against undisturbed ground.
2. All dimensions are in millimetres unless otherwise shown.

STANDARD CHAIN LINK FENCE DETAIL



TOWN of LINCOLN
STANDARD DRAWING

DPW - 702

Rev. No.: 4 Date: Jan. 2018

Scale: N.T.S.

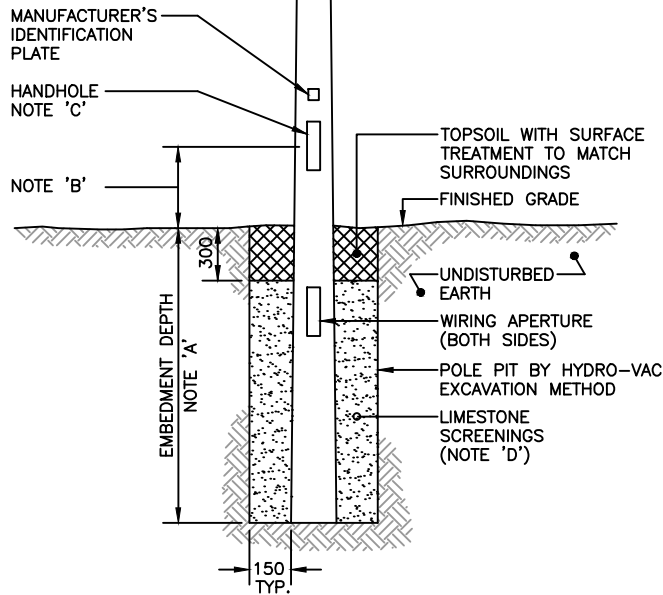
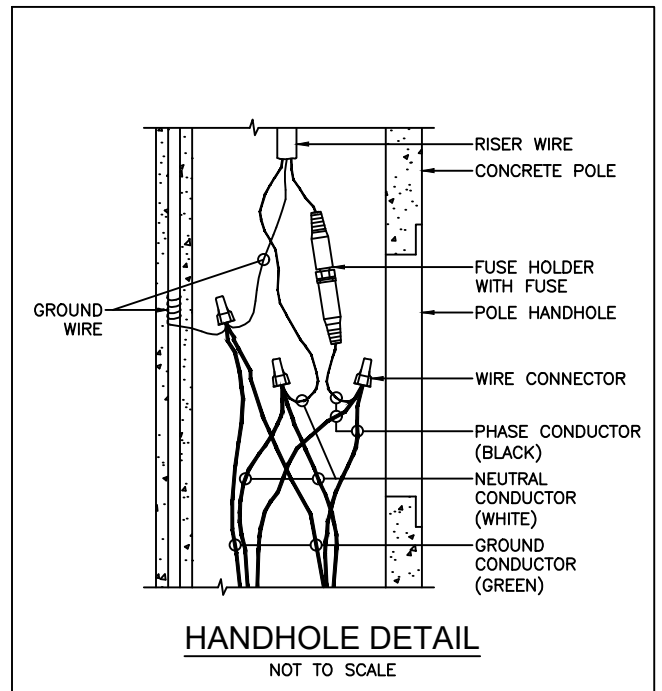
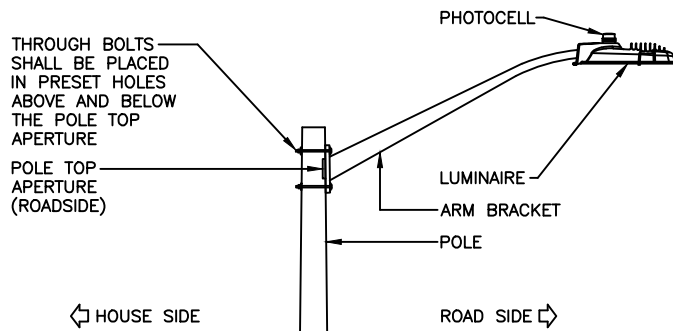

NOTES - INSTALLATION

- A. POLE SHALL BE EMBEDDED IN ACCORDANCE WITH POLE MANUFACTURER'S RECOMMENDATIONS BASED ON LOCALIZED EARTH CONDITIONS.
- B. POLE HANDHOLE DISTANCE TO FINISHED GRADE SHALL BE SET IN ACCORDANCE WITH THE POLE MANUFACTURER'S RECOMMENDATIONS.
- C. POLE SHALL BE ORIENTATED SUCH THAT THE HANDHOLE IS ON THE OPPOSITE SIDE OF THE POLE THAN THE FLOW OF VEHICULAR TRAFFIC.
- D. LIMESTONE FILL SHALL BE COMPLETED INTERMITTENTLY WITH A MINIMUM OF FIVE LIFTS. EACH LIFT SHALL BE TAMPED TO SECURE THE POLE.

NOTES - GENERAL

- 1. ALL DIMENSIONS ARE IN MILLIMETERS UNLESS INDICATED OTHERWISE.
- 2. SEE TOWN OF LINCOLN STANDARD DRAWING DPW-703A 'LIGHTING ASSEMBLY CONVENTIONAL EQUIPMENT LIST' FOR APPROVED EQUIPMENT.
- 3. SEE TOWN OF LINCOLN STANDARD DRAWING DPW-705 FOR DUCT TERMINATIONS AT POLES.

LIGHTING ASSEMBLY CONVENTIONAL INSTALLATION



TOWN of LINCOLN
STANDARD DRAWING

DPW - 703

REV. NO.: 5 | DATE: MAY 2023

SCALE: N.T.S.

EQUIPMENT	DESCRIPTION	MANUFACTURER	CATALOG NUMBER	NOTES
POLE	9.9m (32'-6") ROUND, CLASS B - MEDIUM DUTY, CONCRETE	STRESSCRETE	E-325-BPR-G-M00	PREFERRED USE ON LOCAL ROADS
POLE	11.4m (37'-6") ROUND, CLASS B - MEDIUM DUTY, CONCRETE	STRESSCRETE	E-375-BPR-G-M00	PREFERRED USE ON COLLECTOR AND MAJOR ROADS
ARM BRACKET	1.8m (6') TAPERED ELLIPTICAL ALUMINUM	ALUMINOUS	ALP-RE6M-PF	
ARM BRACKET	2.4m (8') TAPERED ELLIPTICAL ALUMINUM	ALUMINOUS	ALP-RE8M-PF	
LUMINAIRE	EVOLVE SERIES 3000K, WATTAGE AND DISTRIBUTION TO SUIT	GE	ERL1, ERL2	
PHOTOCELL	TRS SERIES LONG LIFE LED PHOTOCONTROL	FP OUTDOOR LIGHTING CONTROLS	TRS-2-CUL	
INSULATING BOOTS	SINGLE CONDUCTOR INSULATING BOOTS FOR NON-BREAKAWAY FUSE HOLDER	EATON	2A0660	
FUSE HOLDER	TRON BUSSMAN SERIES HEB NON-BREAKAWAY FUSE HOLDER	EATON	HEB-AA	
FUSE	BUSSMAN SERIES 10A TIME-DELAY SUPPLEMENTAL FUSE	EATON	FNM-10	
RISER WIRE	NMWU-12/2 COPPER 2/C-#12 AWG (PHASE) 1/C-#14 AWG (GROUND)	SOUTHWIRE	471854	
WIRE CONNECTOR	WING-NUT WIRE CONNECTOR	IDEAL	MODEL 454	

NOTES - GENERAL

1. ALL DIMENSIONS ARE IN MILLIMETERS UNLESS INDICATED OTHERWISE.
2. SEE TOWN OF LINCOLN STANDARD DRAWING DPW-703 'LIGHTING ASSEMBLY CONVENTIONAL INSTALLATION'.

**LIGHTING ASSEMBLY
CONVENTIONAL
EQUIPMENT LIST**



TOWN of LINCOLN
STANDARD DRAWING

DPW - 703A

REV. NO.: 0 | DATE: MAY 2023

SCALE: N.T.S.

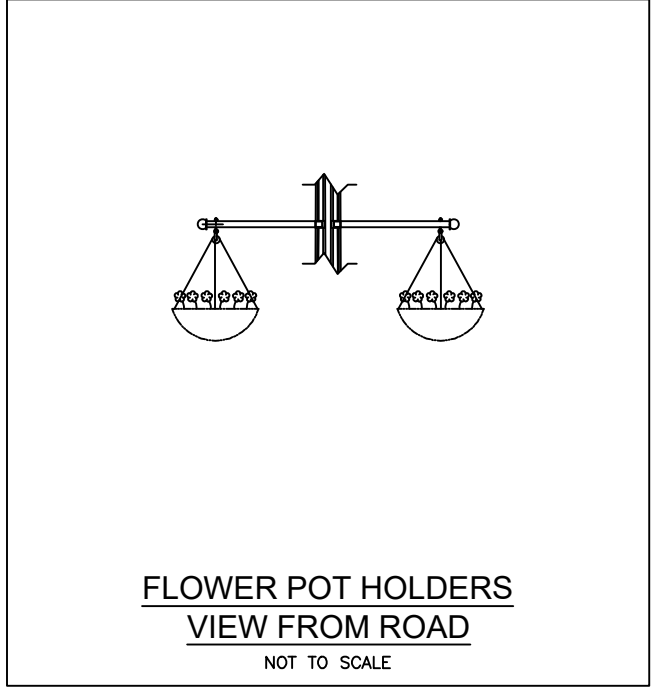
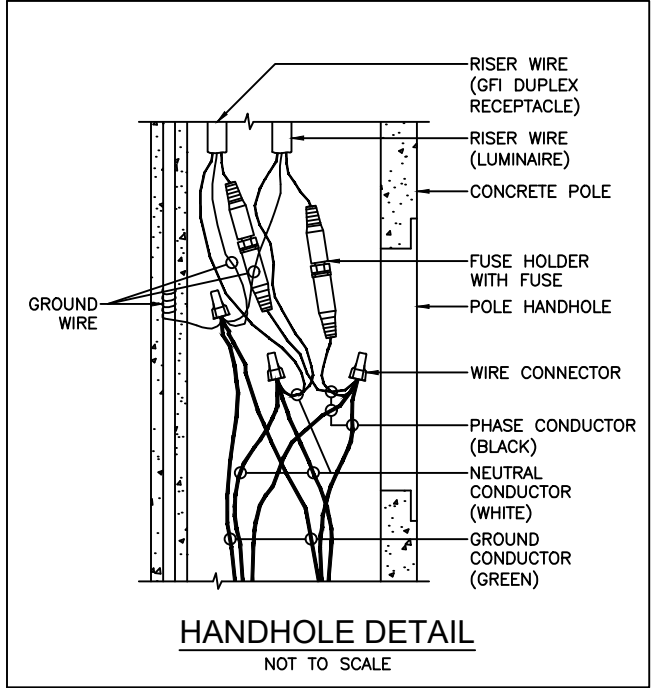
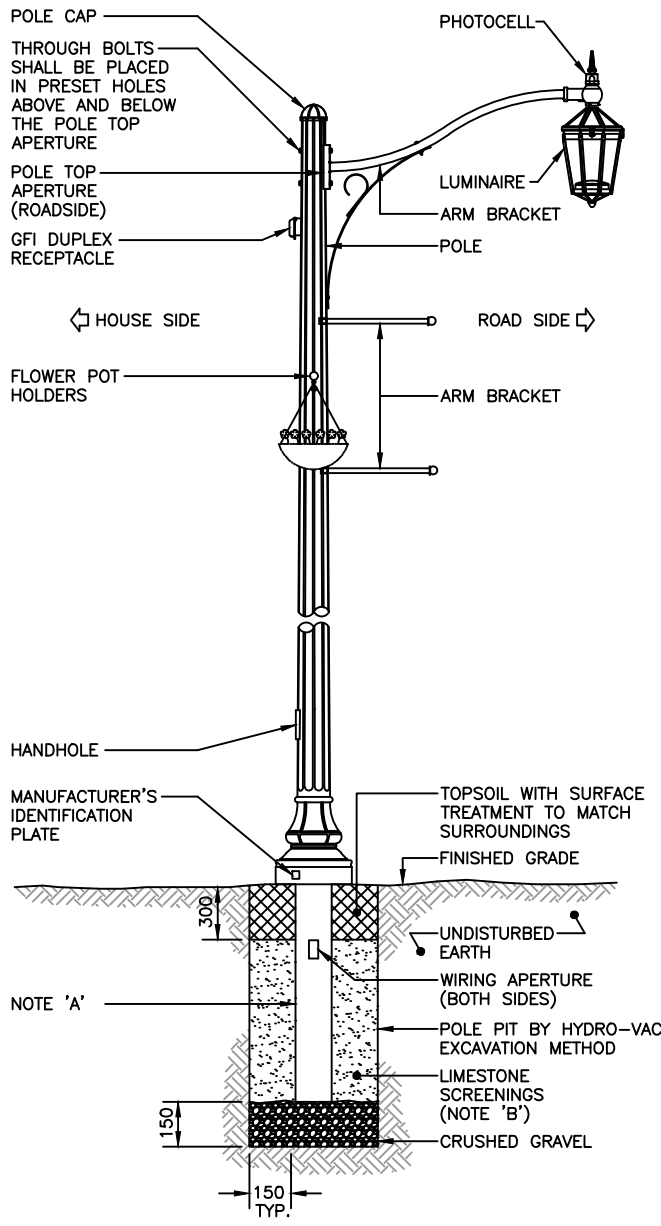

NOTES - INSTALLATION

- A. POLE SHALL BE EMBEDDED IN ACCORDANCE WITH POLE MANUFACTURER'S RECOMMENDATIONS BASED ON LOCALIZED EARTH CONDITIONS.
- B. LIMESTONE FILL SHALL BE COMPLETED INTERMITTENTLY WITH A MINIMUM OF FIVE LIFTS. EACH LIFT SHALL BE TAMPED TO SECURE THE POLE.

NOTES - GENERAL

- 1. ALL DIMENSIONS ARE IN MILLIMETERS UNLESS INDICATED OTHERWISE.
- 2. SEE TOWN OF LINCOLN STANDARD DRAWING DPW-704A 'LIGHTING ASSEMBLY DECORATIVE EQUIPMENT LIST' FOR APPROVED EQUIPMENT.
- 3. SEE TOWN OF LINCOLN STANDARD DRAWING DPW-705 FOR DUCT TERMINATIONS AT POLES.

**LIGHTING ASSEMBLY
DECORATIVE
INSTALLATION**



TOWN of LINCOLN
STANDARD DRAWING

DPW - 704

REV. NO.: 5 DATE: MAY 2023

SCALE: N.T.S.

EQUIPMENT	DESCRIPTION	MANUFACTURER	CATALOG NUMBER	NOTES
POLE	6.1m (20'-0") FLUTED ROUND, ECLIPSE, ETCHED, DECORATIVE CONCRETE	STRESSCRETE	KWH20-G-E11 C/A DR & FC S/F KA30-S	
ARM BRACKET	1.8m (6'-0") SMOOTH BLACK, DECORATIVE ALUMINUM	KING LUMINAIRE	KA30-S-6' C/W KPL-20-PR7-#5	
LUMINAIRE	K56 SERIES	KING LUMINAIRE	K56-C-P-P4NL -III-75(SSL)-7030-120:277 S/F KPL20-PR7-#5	WATTAGE AND DISTRIBUTION TYPE TO BE DETERMINED
PHOTOCELL	TRS SERIES LONG LIFE LED PHOTOCONTROL	FP OUTDOOR LIGHTING CONTROLS	TRS-2-CUL	
GFI	15A/120V GFI DUPLEX RECEPTACLE	N/A	N/A	SUPPLIED AND INSTALLED BY POLE MANUFACTURER
BANNER ARMS	2- 28" LONG WITH CAST BANNER BALL	KING LUMINAIRE	TBD	
FLOWER POT HOLDERS	2 - 24" LONG WITH CAST BANNER BALL	KING LUMINAIRE	TBD	MANUFACTURER SHALL SUPPLY 1/4"-20 EYEBOLTS WITH 1/2" EYELET
INSULATING BOOTS	SINGLE CONDUCTOR INSULATING BOOTS FOR NON-BREAKAWAY FUSE HOLDER	EATON	2A0660	
FUSE HOLDER	TRON BUSSMAN SERIES HEB NON-BREAKAWAY FUSE HOLDER	EATON	HEB-AA	
FUSE	BUSSMAN SERIES 10A TIME-DELAY SUPPLEMENTAL FUSE	EATON	FNM-10	
RISER WIRE	NMWU-12/2 COPPER 2/C-#12 AWG (PHASE) 1/C-#14 AWG (GROUND)	SOUTHWIRE	471854	
WIRE CONNECTOR	WING-NUT WIRE CONNECTOR	IDEAL	MODEL 454	

NOTES - GENERAL

1. ALL DIMENSIONS ARE IN MILLIMETERS UNLESS INDICATED OTHERWISE.
2. SEE TOWN OF LINCOLN STANDARD DRAWING DPW-704 'LIGHTING ASSEMBLY DECORATIVE INSTALLATION'.

**LIGHTING ASSEMBLY
DECORATIVE
EQUIPMENT LIST**



TOWN of LINCOLN
STANDARD DRAWING

DPW - 704A

REV. NO.: 0 DATE: MAY 2023

SCALE: N.T.S.

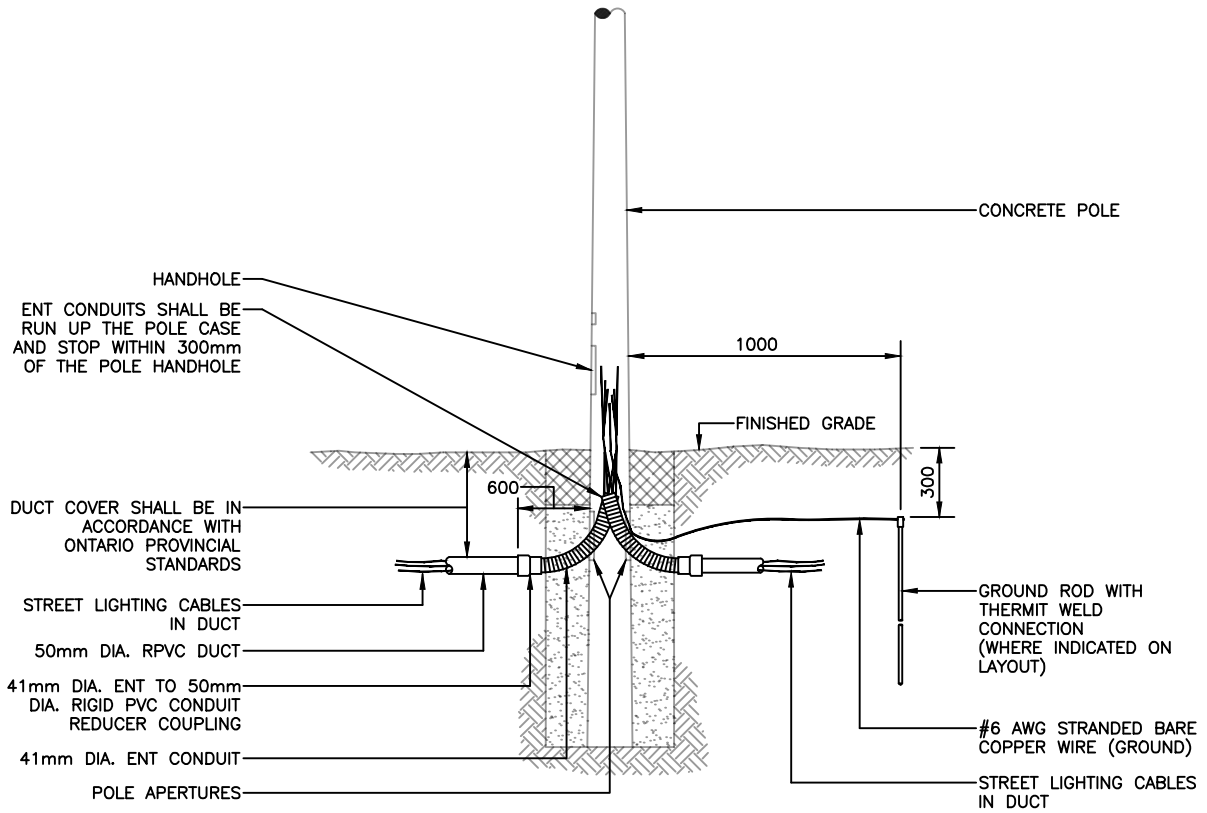

NOTES – INSTALLATION

- A. ALL DUCT, FITTINGS, ACCESSORIES AND SOLVENTS SHALL BE SUPPLIED BY THE SAME MANUFACTURER.
- B. ALL DUCTS AND FITTINGS SHALL BE CONNECTED IN ACCORDANCE WITH DUCT MANUFACTURERS RECOMMENDATIONS, UTILIZING SOLVENT WELDS.
- C. AREAS DISTURBED BY POLE INSTALLATION SHALL BE REINSTATED TO MATCH SURROUNDING EXISTING CONDITIONS.

NOTES – GENERAL

- 1. ALL DIMENSIONS ARE IN MILLIMETERS UNLESS INDICATED OTHERWISE.

DUCT TERMINATION AT EMBEDDED CONCRETE POLES



TOWN of LINCOLN
STANDARD DRAWING

DPW - 705

REV. NO.: 0 DATE: MAY 2023

SCALE: N.T.S.

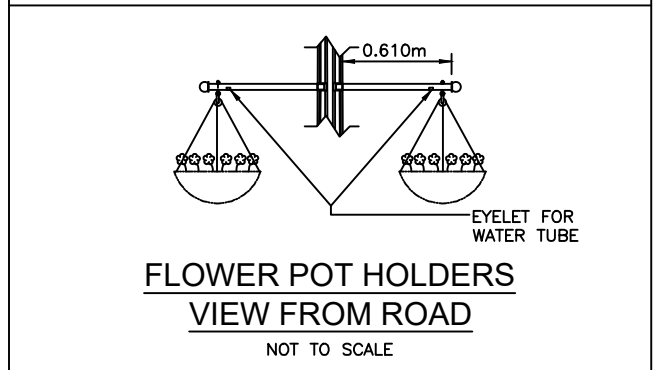
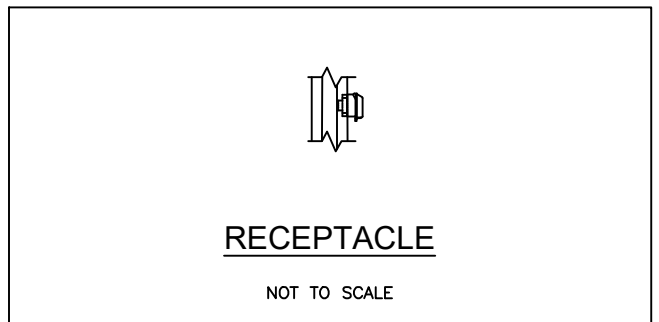
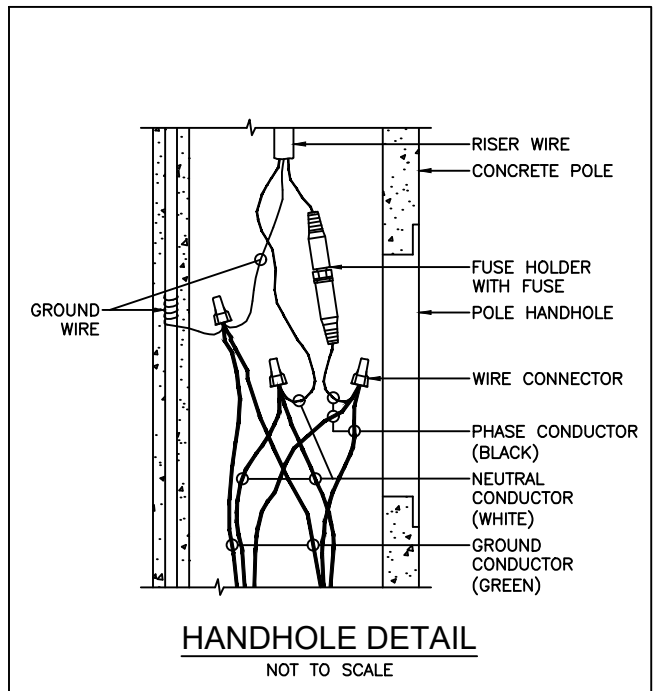
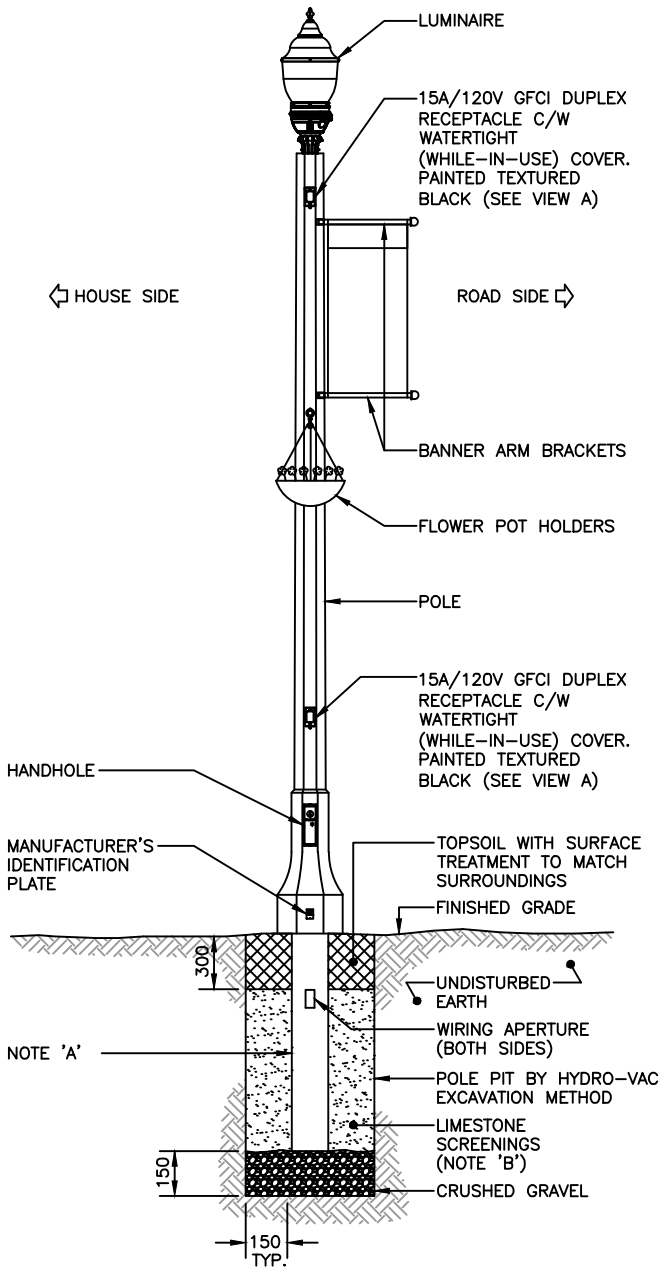

NOTES - INSTALLATION

- A. POLE SHALL BE EMBEDDED IN ACCORDANCE WITH POLE MANUFACTURER'S RECOMMENDATIONS BASED ON LOCALIZED EARTH CONDITIONS.
- B. POLE HANDHOLE DISTANCE TO FINISHED GRADE SHALL BE SET IN ACCORDANCE WITH THE POLE MANUFACTURER'S RECOMMENDATIONS.
- C. POLE SHALL BE ORIENTATED SUCH THAT THE HANDHOLE IS ON THE OPPOSITE SIDE OF THE POLE THAN THE FLOW OF VEHICULAR TRAFFIC.
- D. LIMESTONE FILL SHALL BE COMPLETED INTERMITTENTLY WITH A MINIMUM OF FIVE LIFTS. EACH LIFT SHALL BE TAMPED TO SECURE THE POLE.

NOTES - GENERAL

- 1. ALL DIMENSIONS ARE IN MILLIMETERS UNLESS INDICATED OTHERWISE.
- 2. SEE TOWN OF LINCOLN STANDARD DRAWING DPW-706A 'LIGHTING ASSEMBLY DECORATIVE (TYPE 3) EQUIPMENT LIST' FOR APPROVED EQUIPMENT.
- 3. SEE TOWN OF LINCOLN STANDARD DRAWING DPW-705 FOR DUCT TERMINATIONS AT POLES.

**LIGHTING ASSEMBLY
DECORATIVE (TYPE 3)
INSTALLATION**



**TOWN of LINCOLN
STANDARD DRAWING**

DPW - 706

REV. NO.: 0 DATE: FEB. 2025

SCALE: N.T.S.

EQUIPMENT	DESCRIPTION	MANUFACTURER	CATALOG NUMBER	NOTES
POLE	5.5m (18'-0") OCTAGONAL, ECLIPSE, POLISHED, CONCRETE	KING LUMINAIRE - STRESSCRETE	KMH18-G-S11 C/W 140-35/35 & DR & BA & FPH	PREFERRED USE ON LOCAL ROADS - DOWNTOWN CORE
POLE	7.6m (25'-0") OCTAGONAL, ECLIPSE, POLISHED, CONCRETE	KING LUMINAIRE - STRESSCRETE	KMH25-G-S11-FBP C/W 140-35/35 & (2) DR & BA & FPH & BPC	PREFERRED USE IN PARKING LOTS
LUMINAIRE	K423R-P4AV 3000K, WATTAGE AND DISTRIBUTION TO SUIT	KING LUMINAIRE	K423R-P4AV	25W, 40W, 60W, 75W, 100W WITH 3000 TO 9000 LUMENS
PHOTOCELL	TRS SERIES LONG LIFE LED PHOTOCONTROL	FP OUTDOOR LIGHTING CONTROLS	TRS-2-CUL	
INSULATING BOOTS	SINGLE CONDUCTOR INSULATING BOOTS FOR NON-BREAKAWAY FUSE HOLDER	EATON	2A0660	
FUSE HOLDER	TRON BUSSMAN SERIES HEB NON-BREAKAWAY FUSE HOLDER	EATON	HEB-AA	
FUSE	BUSSMAN SERIES 10A TIME-DELAY SUPPLEMENTAL FUSE	EATON	FNM-10	
RISER WIRE	NMWU-12/2 COPPER 2/C-#12 AWG (PHASE) 1/C-#14 AWG (GROUND)	SOUTHWIRE	471854	
WIRE CONNECTOR	WING-NUT WIRE CONNECTOR	IDEAL	MODEL 454	

NOTES - GENERAL

1. ALL DIMENSIONS ARE IN MILLIMETERS UNLESS INDICATED OTHERWISE.
2. SEE TOWN OF LINCOLN STANDARD DRAWING DPW-706 'LIGHTING ASSEMBLY DECORATIVE (TYPE 3) INSTALLATION'.

**LIGHTING ASSEMBLY
DECORATIVE (TYPE 3)
EQUIPMENT LIST**



TOWN of LINCOLN
STANDARD DRAWING

DPW - 706A

REV. NO.: 0 | DATE: FEB. 2025

SCALE: N.T.S.

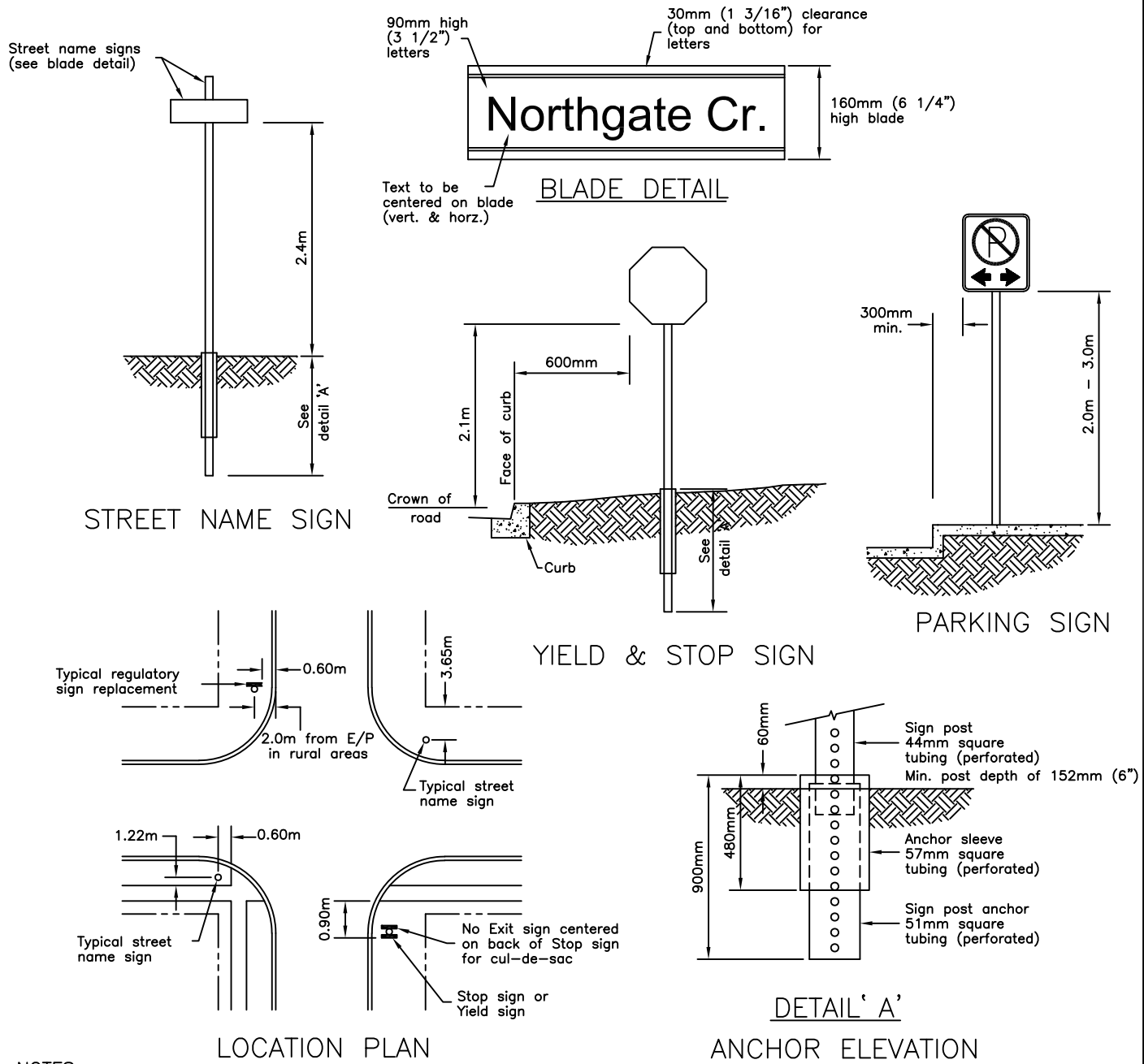

NOTES

1. Colour, shape, and size of all warning and regulatory signs shall conform to the most current iterations of the Manual for Uniform Traffic Control Devices for Ontario, the Ontario Traffic Manuals, and Minimum Maintenance Standards.
2. All regulatory signs shall be mounted at approximately right angles to the direction of traffic that they are intended to serve, except for "No Parking" or "No Stopping" signs.
3. "No Parking" and "No Stopping" signs shall be placed at an angle of no less than 30°, and no more than 45° to a line parallel to the flow of traffic.
4. For signs 900mm square or smaller, see detail 'A'.
5. For signs larger than 900mm square:
 - Sign posts to be 51mm square tubing or 100mmx100mm pressure treated wood posts (sunk 1.0m below surface),
 - Sign post anchor to be 57mm square tubing,
 - Anchor sleeve to be 63mm square tubing.
6. Signs attached to tubing using 5/16" "washer and bolts".
7. All dimensions are in millimetres unless otherwise shown.

**WARNING & REGULATORY
SIGNS AND STREET NAME
SIGN INSTALLATION**

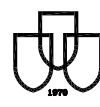

**TOWN of LINCOLN
STANDARD DRAWING**

DPW - 707

Rev. No.: 5 Date: Nov 2022

Scale: N.T.S.

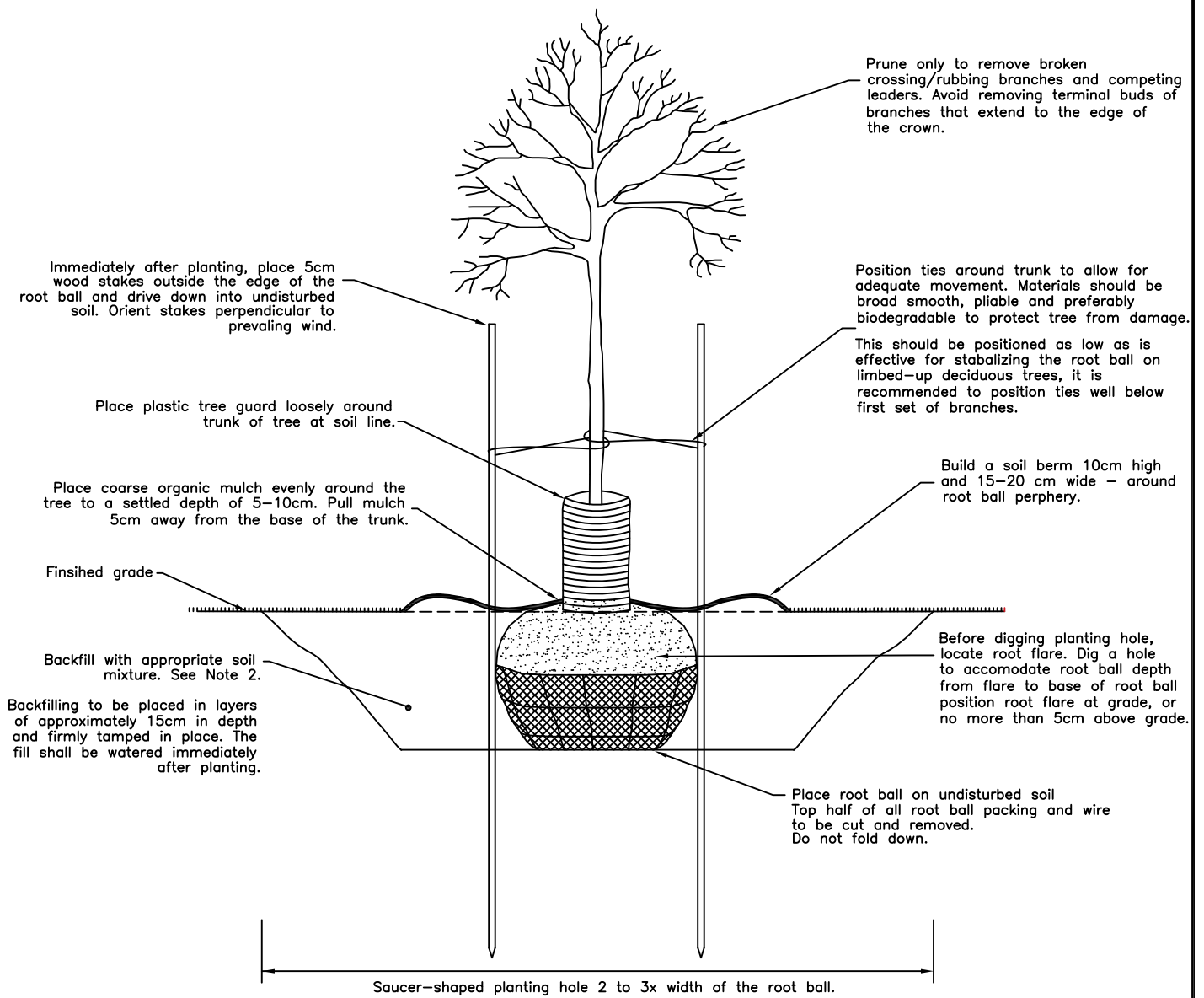

NOTE

1. Refer to the Ontario landscape Tree Planting Guide (2019) to determine best practices, information and associated details that may apply to the particular planting site, including the planting of bare root or container-grown trees.
2. Specifications for backfill are as follows:

Soil Texture	Sand %	Silt %	Clay %
Clay-loam	20-46	20-50	27-40
Sandy-loam	55-80	5-28	10-20

Clay soil contains minimum 4% organic matter. Sandy soil contains minimum 2% organic matter.
 Acidity of top soil mixture to range between 6.0pH to 7.5pH.
 Top soil mixture to be free of sub-soil, stones, roots and any foreign objects.

3. Tree setbacks shall be a minimum 1.0m from major undergrounds utilities, 4.5m from street lights, 1.5m from transformer (3.0m from opening), 1.5m from driveways, sidewalks, or curb cuts, 9.0m from regulatory traffic signs and 10.0m from intersections.
4. Dig planting hole a minimum of 60cm wider than the widest dimensions of the root ball.
5. Plant tree within 24 hours of delivery.
6. Thoroughly irrigate root ball upon installation with a hose.

DECIDUOUS TREE PLANTING
40mm, 50mm, 60mm
CALIPER

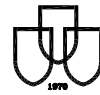

TOWN of LINCOLN
STANDARD DRAWING

DPW - 708

Rev. No.: 4 Date: Jan 2025
 Scale: N.T.S.

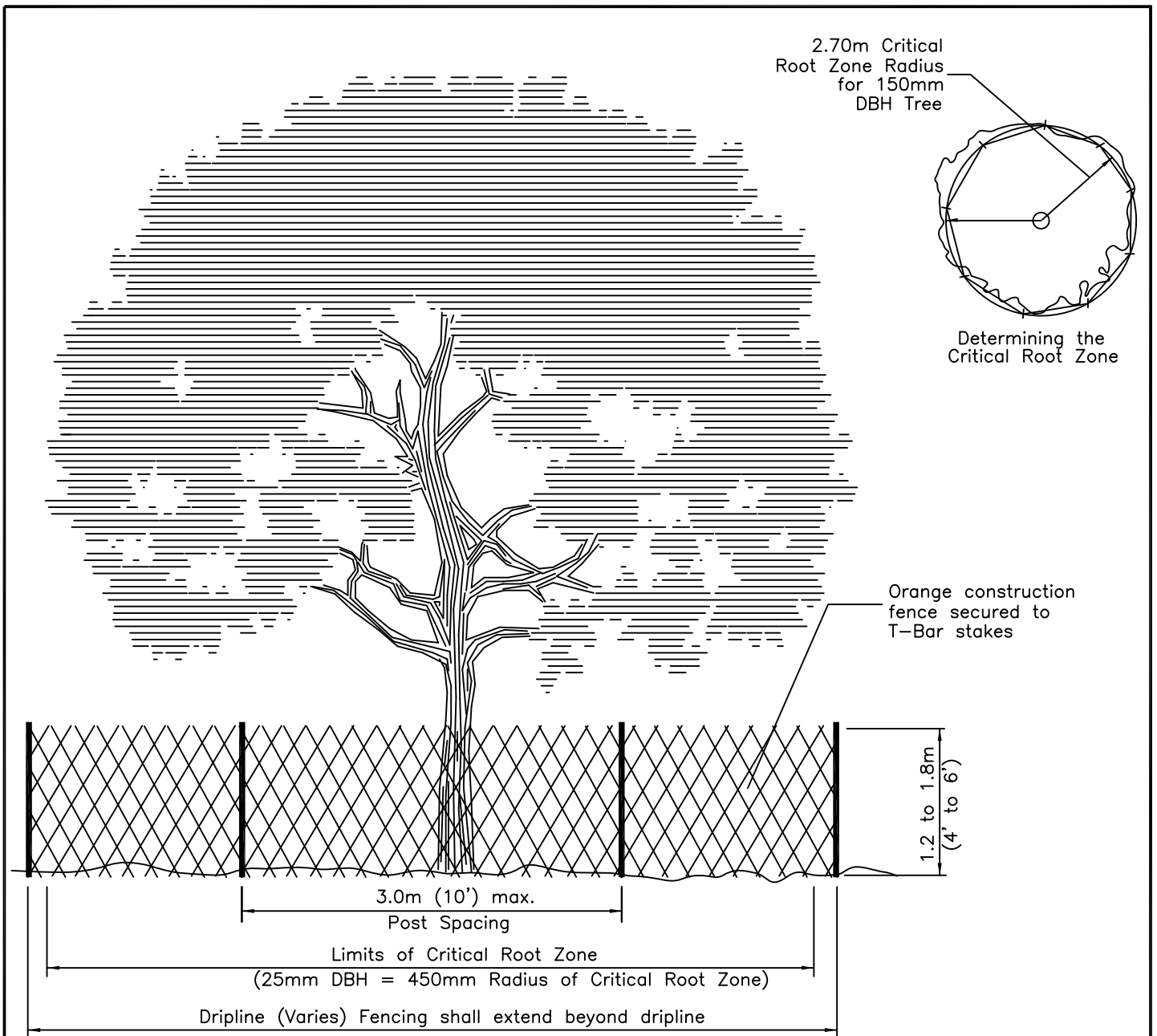

NOTES

1. This area within the dripline of all existing trees shall be properly protected with temporary fencing.
2. The area within the protective fencing shall remain undisturbed and shall not be used for storage of building materials, equipment or project related garbage.
3. Tree protection measures shall remain until the completion of fine grading and sodding/seeding.
4. Signage shall be affixed to the fencing that says "No Entry! Tree Protection Zone" on each side of the tree protection zone.
5. Critical Root Zone
 - a) The critical root zone of a tree is the zone in which the majority of the tree's root lay. Ninety-five (95%) of the roots of most trees will be found in the upper 30-36" of the soil. Of those, the majority of the roots that supply the nutrients and water to the tree are found in the uppermost layer. Just below the soil surface. The total amount of a tree's roots are generally proportional to the volume of the tree's canopy. Therefore, if the roots only penetrate a thin layer of soil, then the roots must spread far from the tree, beyond the limits of the canopy.
 - b) Roots are vital to the functioning of any tree. They provide structural support as well as the major mechanism for nutrient and water uptake for use by the rest of the tree. Destroying a section of a tree's roots will ultimately result in a proportional loss of the tree's canopy.
 - c) The critical root zone of a tree to be saved shall be the minimum area protected with tree protection fencing.

TREE PROTECTION FENCING



**TOWN of LINCOLN
STANDARD DRAWING**

DPW - 709

Rev. No.: 0 Date: Jan 2025

Scale: N.T.S.

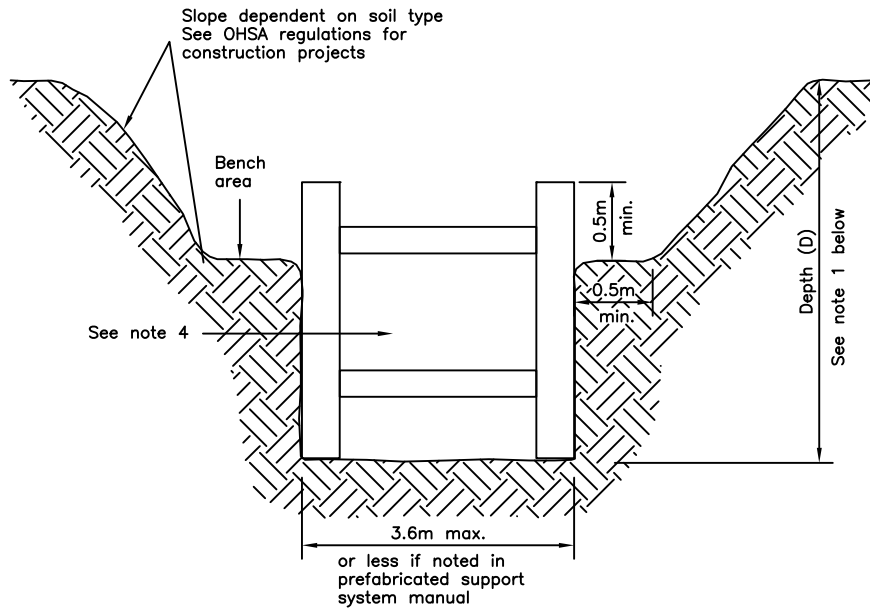
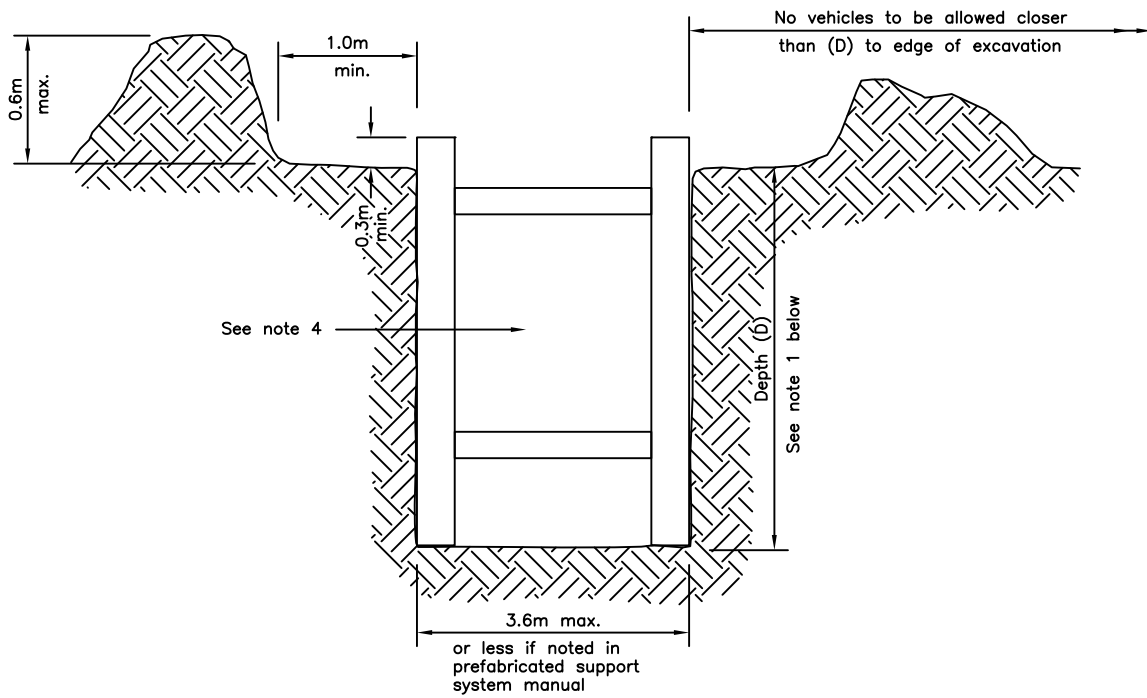

NOTES:

1. Maximum trench depth is as follows:
 - i) For underground pipe breaks, the maximum depth of trench permitted is 3.6m or less if specified in the manufacturer's drawings and specifications.
 - ii) For construction, the maximum depth of the trench permitted is 6.0m or less if specified in the manufacturer's drawings or specifications.
2. Prefabricated support system to be installed as per the manufacturer's specifications.
3. All dimensions apply to both sides of trench.
4. For underground pipe breaks, end pieces to be installed as per the manufacturer's drawings and specifications.
5. For type 4 soil, prefabricated system cannot be used.

**TYPICAL PREFABRICATED
TRENCH PROTECTION
ARRANGEMENT**



**TOWN of LINCOLN
STANDARD DRAWING**

DPW - 710

Rev. No.: 2 | Date: Sept. 2002

Scale: N.T.S.

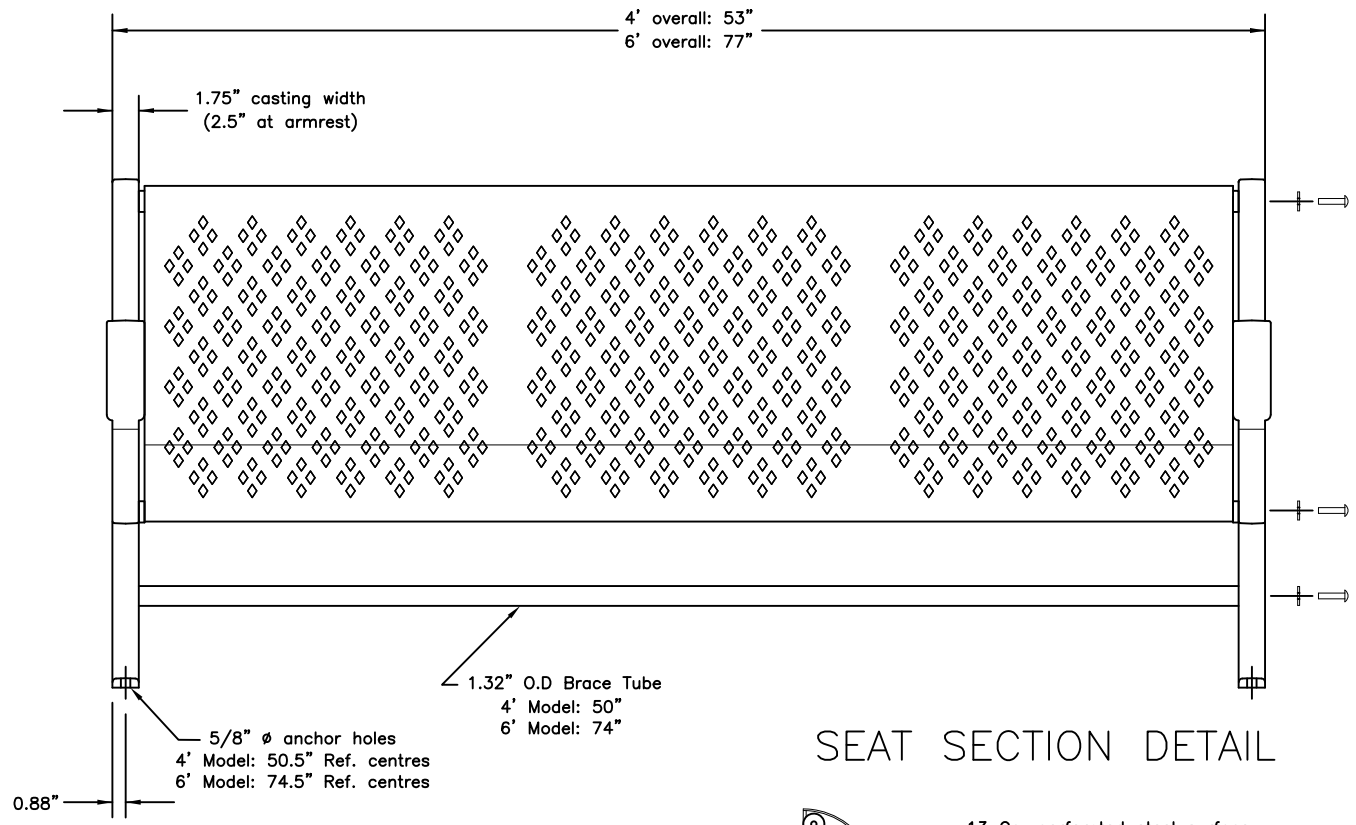

SEAT SECTION DETAIL

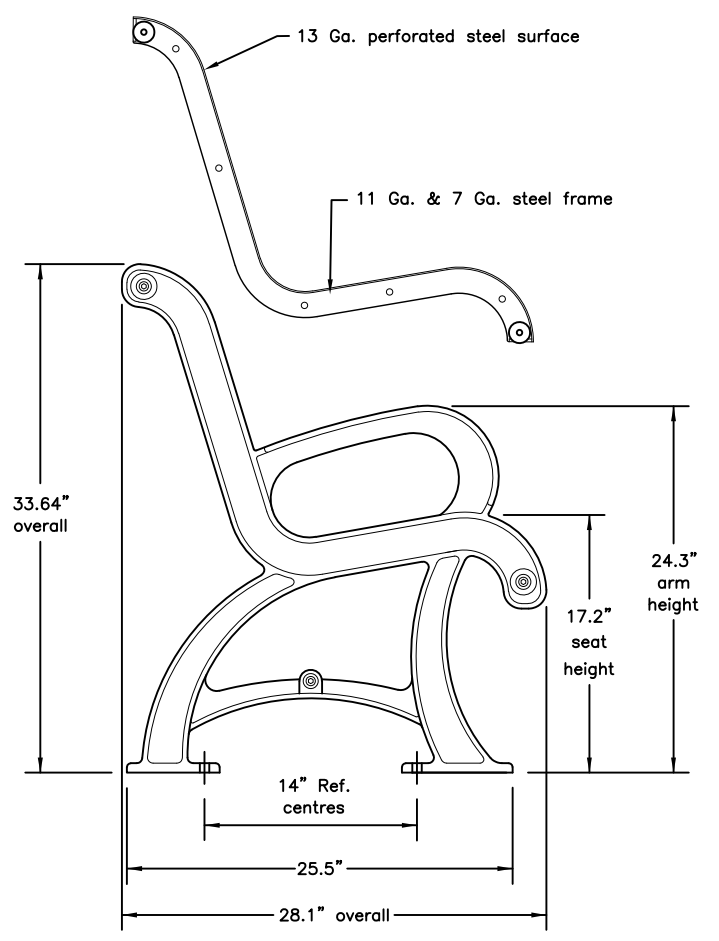

- NOTES:**
1. Bench Manufacturer: - Paris Equipment Manufacturing Ltd.
- SPEC. NO. P_4CSS, P_6CSS
 2. Aluminum frame with perforated diamond pattern steel seating, finished with polyester powder coating painted black.
 3. Hardware shall be stainless steel and vandal resistant.
 4. All dimensions are in inches unless otherwise shown.

STANDARD BENCH

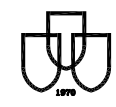

TOWN of LINCOLN
STANDARD DRAWING

DPW - 711

Rev. No.: 2 | Date: Jan. 2018
Scale: N.T.S.

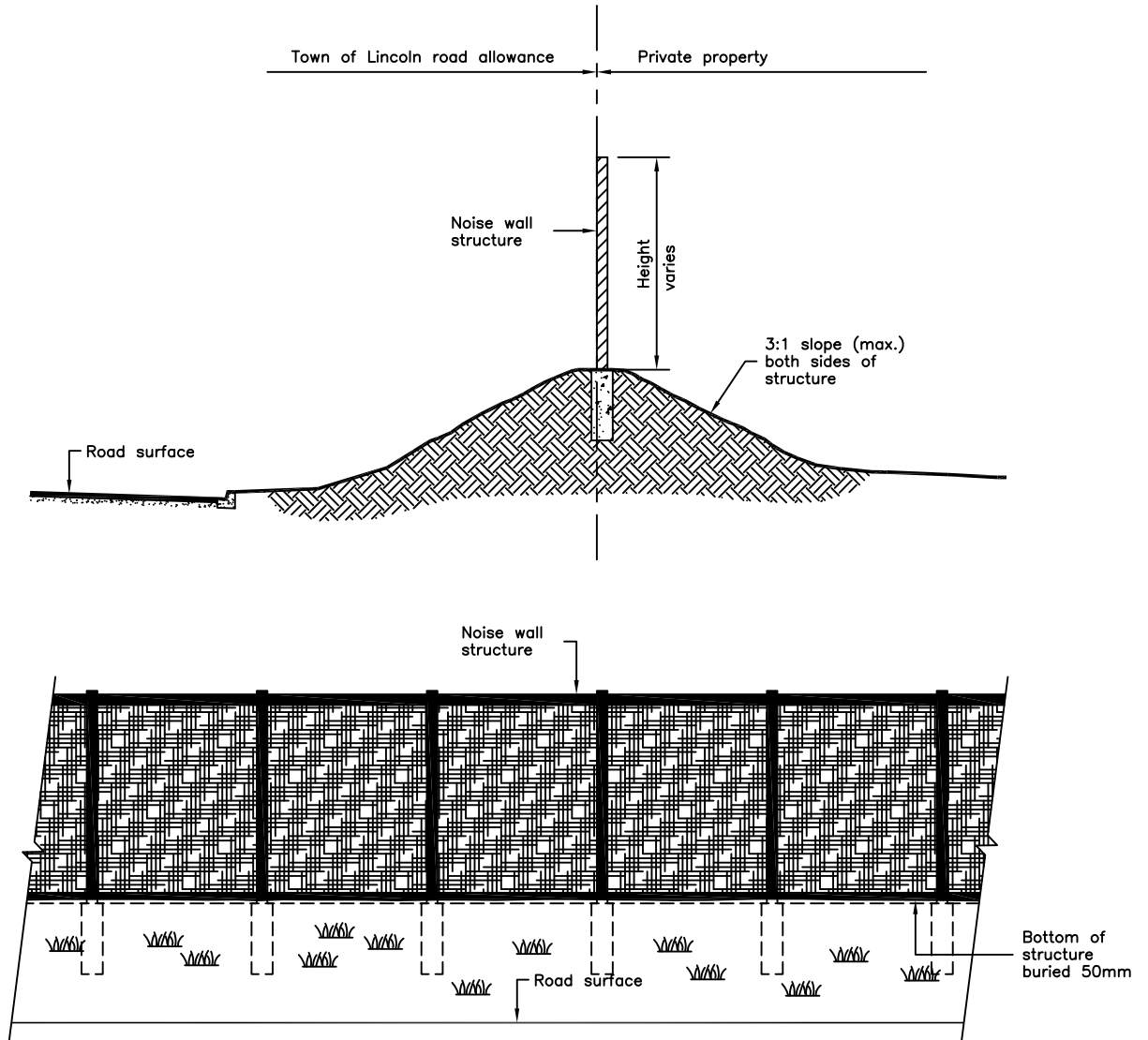

NOTES:

1. Noise wall structure to be approved by the Ministry of Environment.

TYPICAL NOISE WALL LAYOUT



TOWN of LINCOLN
STANDARD DRAWING

DPW - 712

Rev. No.: Date: Apr. 2004

Scale: N.T.S.

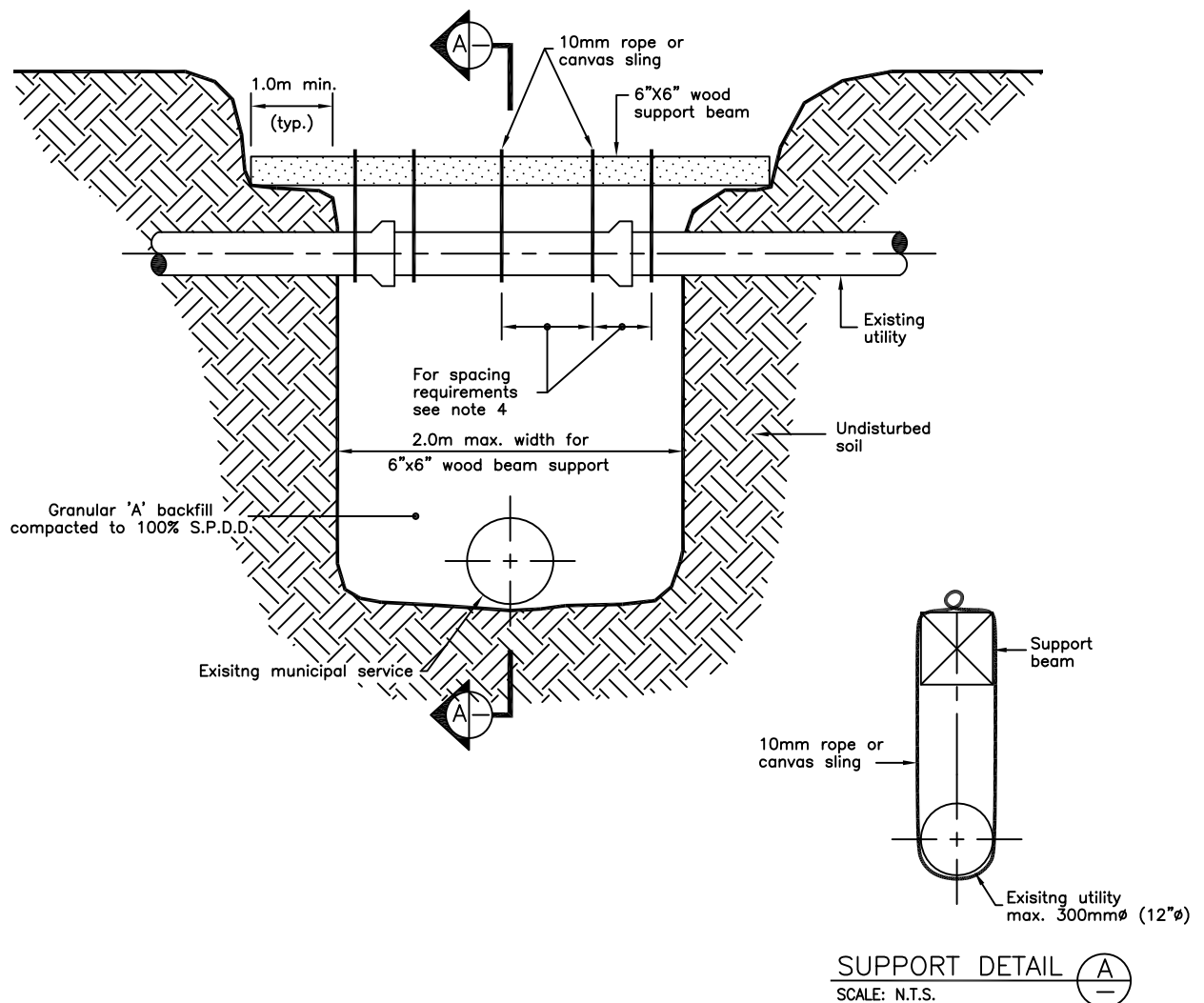

NOTES

1. Temporary support shall remain in place until the backfill material underneath the utility is compacted adequately to restore support.
2. Mechanical equipment shall not be operated within 0.3m of a utility. Hand excavation shall be performed when locating and digging within 0.3m of a utility.
3. Hand held compaction equipment shall be used within 1.0m of the sides or top of utilities.
4. All exposed joints shall be supported by canvas sling or rope at either side of the joint and at 1.0m max. spacings along the utility's length
5. The support beam shall be one continuous length grade No. 1 spruce-pine-fir (S-P-F) or equivalent and shall be placed above the utility with the ends placed on undisturbed soil.
6. For utilities over 300mm \varnothing (12" \varnothing) refer to utility company for temporary support requirements.

SUPPORT DETAIL (A)
SCALE: N.T.S.

**TYPICAL UTILITY
SUPPORT**



**TOWN of LINCOLN
STANDARD DRAWING**

DPW - 713

Rev. No.: Date: Mar. 2005

Scale: N.T.S.

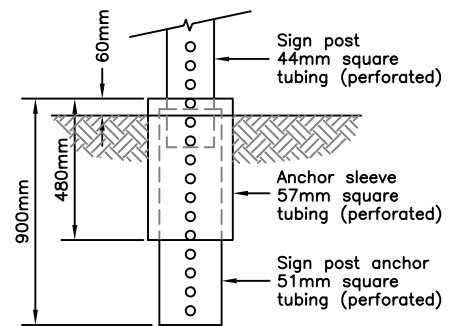
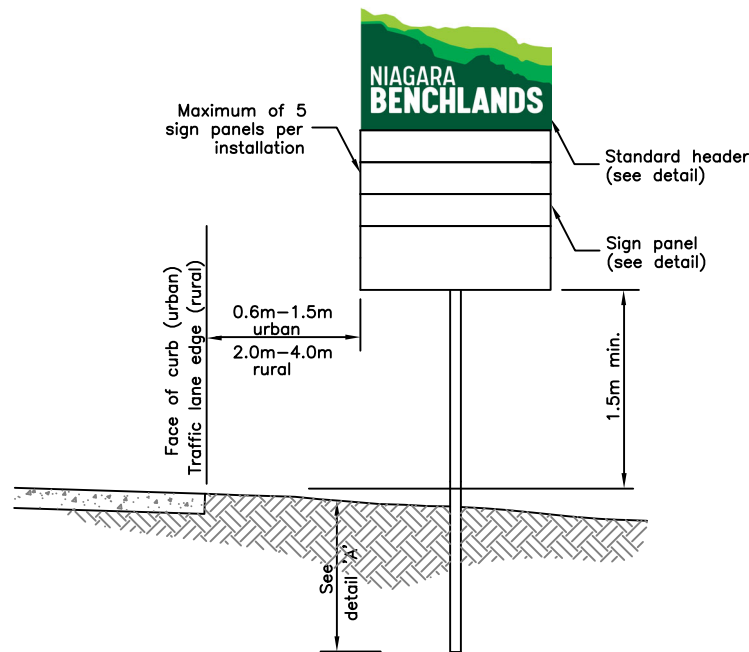
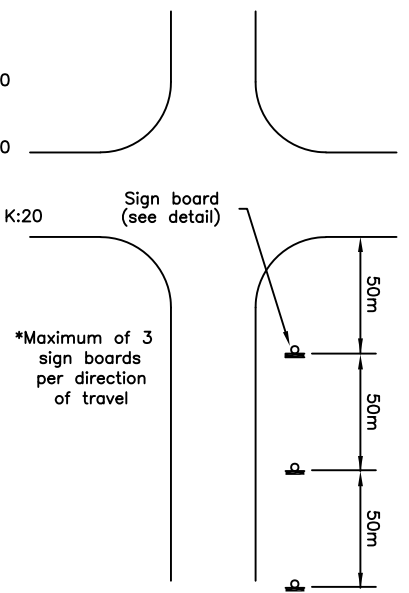
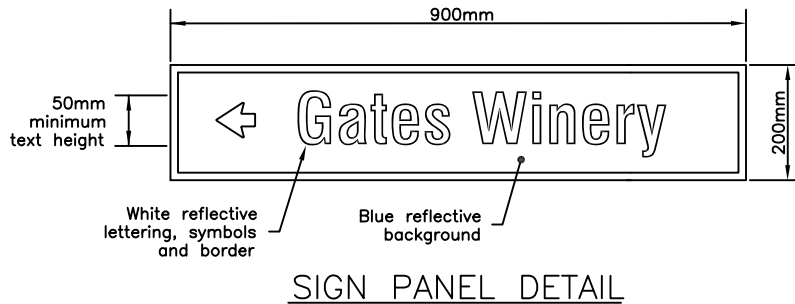
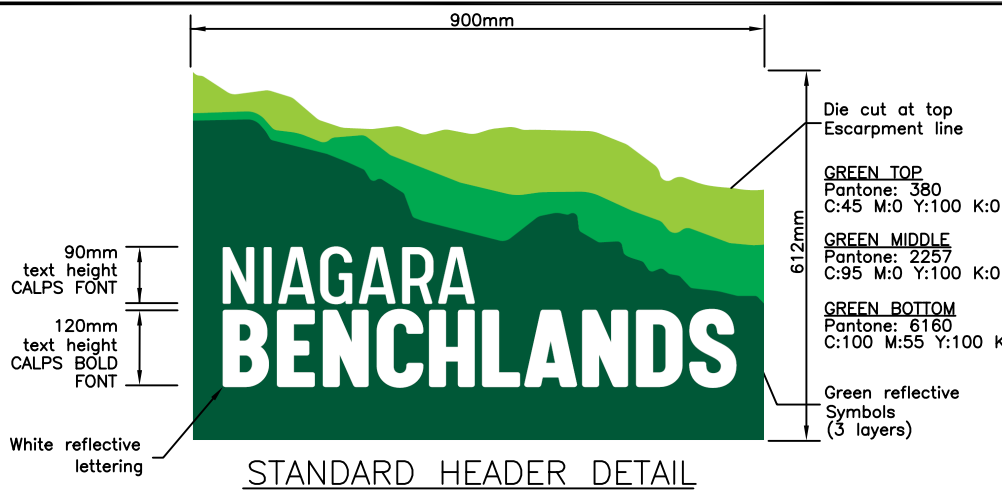

NOTES

1. Sign reflectivity shall conform to Ontario Traffic Manual Standards.
2. All signs shall be mounted at approximately right angles to the direction of traffic they are intended to serve.
3. All signs to be installed as per DPW-706 Sign Installation Standard.
4. Sign panel text shall be minimum 50mm high, centered horizontally and vertically. A maximum of 2 lines of text will be permitted per sign panel.
5. All dimensions are in millimeters unless otherwise shown.

**TOURIST DIRECTIONAL SIGN
INSTALLATION**



**TOWN of LINCOLN
STANDARD DRAWING**

DPW - 714

Rev. No.: 3 Date: Feb 2025

Scale: N.T.S.

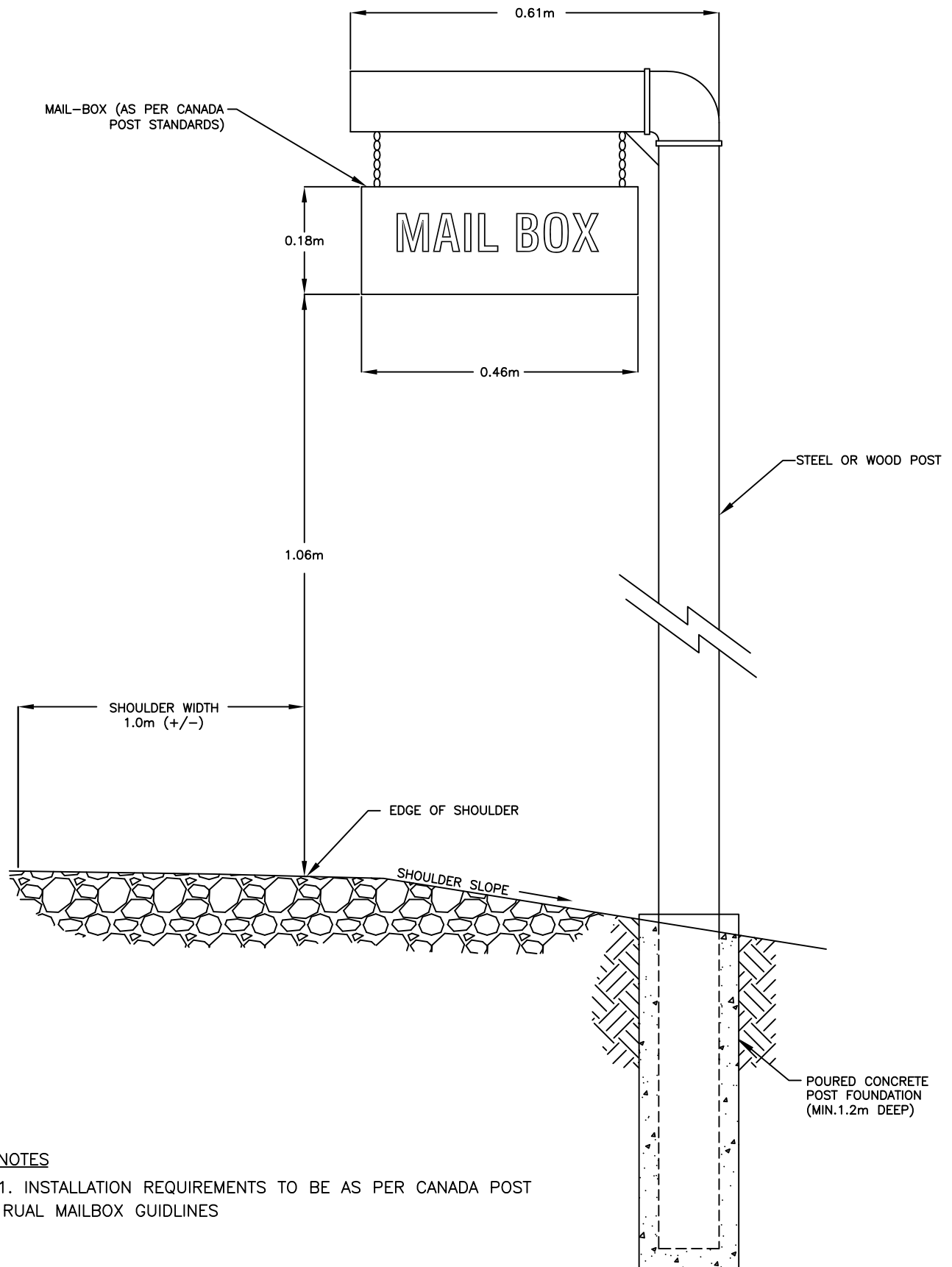

NOTES

1. INSTALLATION REQUIREMENTS TO BE AS PER CANADA POST RUAL MAILBOX GUIDLINES

RURAL MAIL BOX



TOWN of LINCOLN
STANDARD DRAWING

DPW - 715

Rev. No.: 1 | Date: Feb. 2018

Scale: N.T.S.

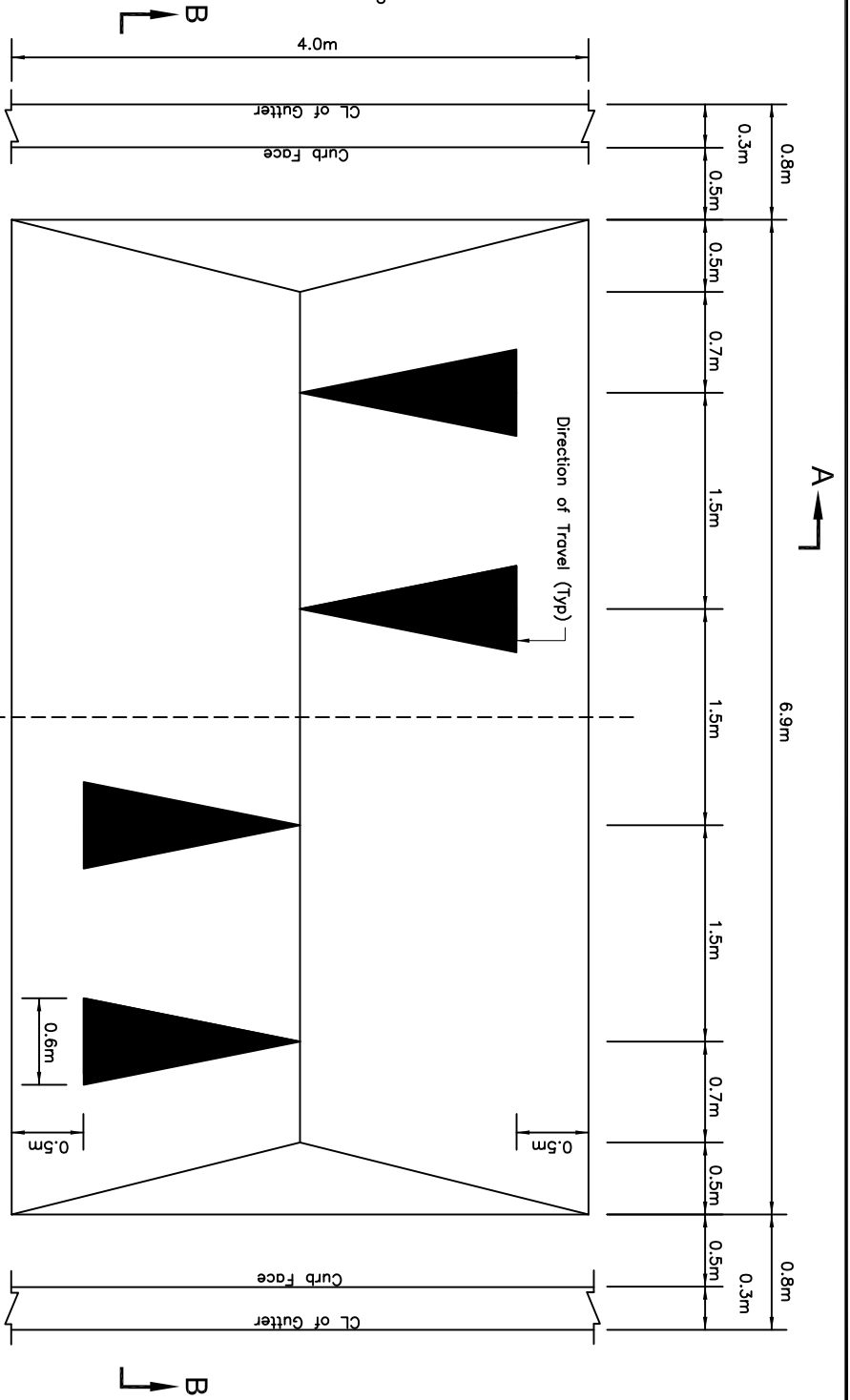
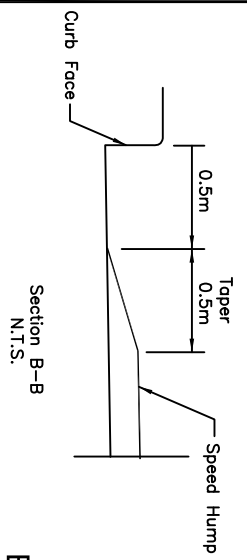
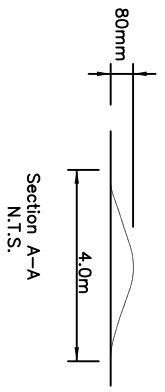

NOTES

1. This standard is specific to 8.5m urban residential roads.
2. Square saw cut existing asphalt and mill 50mm deep below existing road surface. Road must be thoroughly cleaned including all edges of excavation be swept clean with a stiff bristle broom to remove loose debris prior to tack coat.
3. All edges to be primed using Denso Primer D or Denso aerosol spray adhesive, followed by Densoband tape on all existing edges, installed as per manufacturers recommendations.
4. Tack coat must be applied before placement of HL3 as per NPSCD's.
5. Speed Hump to be constructed with HL3 asphalt (full depth) as per OPSS 310.
6. All painting shall be Thermoplastic Paint—white in colour, including glass beads.
7. Speed hump to be 80mm from existing road surface to top of the hump.
8. Wa-74 Speed Bump sign including Wa-74t Speed Hump tab sign to be installed on each side of speed hump in boulevard (double sided).

Galvanized square posts with 3' square sleeves to be used. Signs to be installed as per DPW-706.

9. Sightlines must be reviewed to ensure signs can be viewed by all vehicles approaching.
10. All units in metres unless otherwise noted.

ASPHALT SPEED HUMP (8.5m URBAN LOCAL ROAD)



**TOWN of LINCOLN
STANDARD DRAWING**

DPW - 716

Rev. No.: 3	Date: Dec 2023
Scale: N.T.S.	

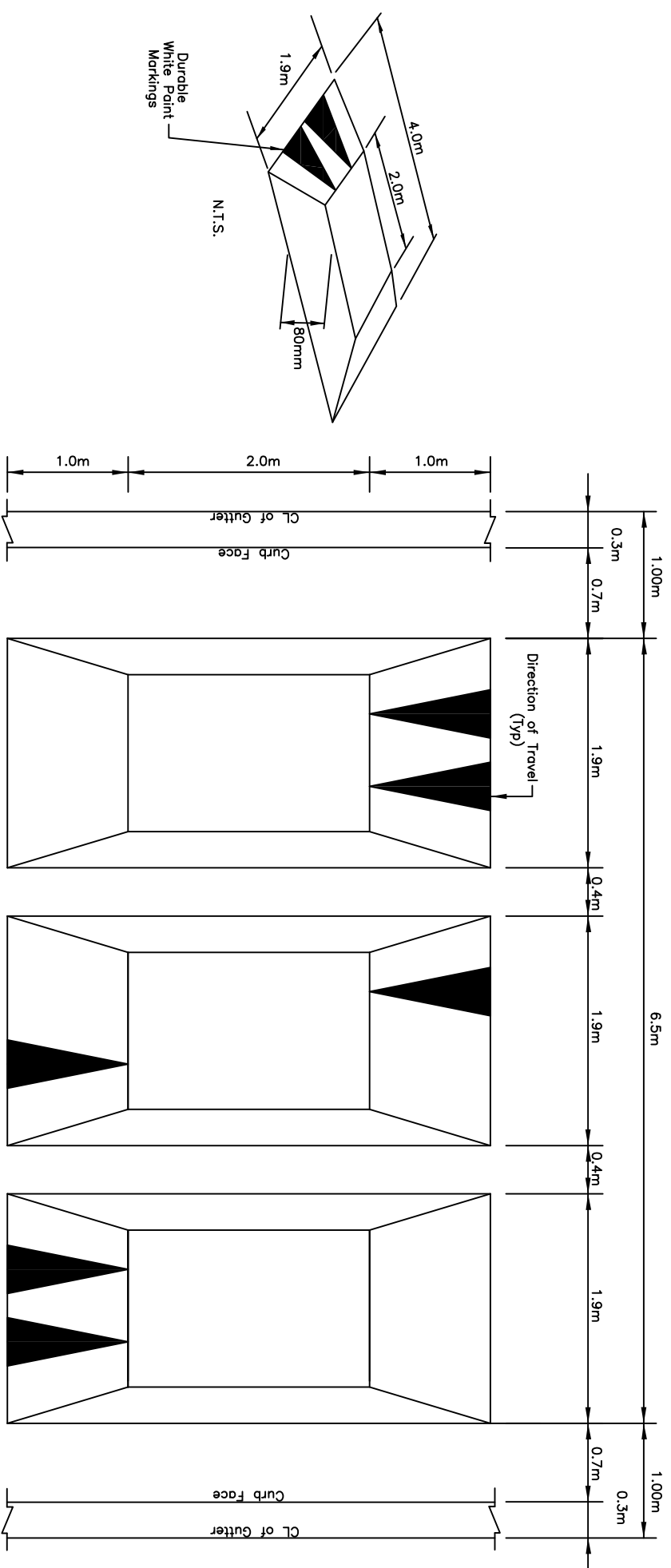

NOTES

1. This standard is specific to 8.5m urban residential roads.
2. Square saw cut existing asphalt and mill 50mm deep below existing road surface. Road must be thoroughly cleaned including all edges of excavation be swept clean with a stiff bristle broom to remove loose debris prior to tack coat.
3. All edges to be primed using Denso Primer D or Denso aerosol spray adhesive, followed by DensoBand tape on all existing edges, installed as per manufacturers recommendations.
4. Tack coat must be applied before placement of HL3 as per NPSCD's.
5. Speed Cushion to be constructed with HL3 asphalt (full depth) as per OPSS 310.
6. All painting shall be Durable Paint white in colour.
7. Speed cushion to be 80mm from existing road surface to top of the cushion.
8. Wa-74 Speed Bump sign including Wa-74t Speed Hump tab sign to be installed on each side of speed hump in boulevard (double sided).

Galvanized square posts with 3' square sleeves to be used. Signs to be installed as per OTM Book 6 Warning Signs and Design Principles (Fig 5).

9. Sightlines must be reviewed to ensure signs can be viewed by all vehicles approaching.
10. All units in metres unless otherwise noted.

**ASPHALT SPEED CUSHIONS
(8.5m URBAN COLLECTOR ROAD)**



**TOWN of LINCOLN
STANDARD DRAWING**

DPW - 717

Rev. No.: 2 Date: Jan 2025
Scale: N.T.S.

APPENDIX A
Document Revision



Document Revision Table

QMS Manual Title:

Municipal Design and Quality Standards

No.	Revision Date (M/D/Y)	Change	By
1	07/01/08	- Previous manual updated to meet QMS document control requirements - Issued for Council approval	B.W.
2	08/22/08	- Update for revisions to QMS Procedures and Forms	B.W.
3	06/12/17	-Test Tap Sample Station Added -LED Streetlight Details Added (DPW 703 and 704) -Check Valve DPW 610 Added -By-Pass DPW 611 Added	D.M.
4	May 1, 2023	-DPW 707 -Update Tree Standard	D.M
5	May 1, 2023	-DPW 703, 704 Updates (Additional DPW 703A, 704A and 705 added) (Streetlights)	D.M.
6	May 3, 2023	-Water Meter Chamber Updates (25mm and 6-8" Flowmeter Chambers)	D.M.
7	May 3, 2023	-Changes to DPW #'s (DPW 605, DPW 606, DPW 607, DPW 608, DPW 609, DPW 610, DPW 611)	D.M.
8	May 3, 2023	-Delete DPW 611 and DPW 612	D.M.
9	May 3, 2023	-Revise Spec 5.3.7 (c) i – change 250mm to 300mm diameter to 750mm diameter	D.M.
10	Oct 12, 2023	- Add Sec 4.1 Infiltration note at assumption (0.018 l/s/ha)	D.M.
11	Dec 13, 2023	Design Spec (Sec 2.4.10) – added more details on parking spec's	D.M.
12	Dec 13, 2023	Design Sepc (Sec 4.2.7 (e)) – added membrane or petrolatum tape for the exterior of manholes	D.M



Document Revision Table

No.	Revision Date (M/D/Y)	Change	By
13	Dec 13, 2023	Design spec (Sec 6.16 (f)) – added that all firelines must be metered with backflow. Water used for fire fighting will not be charged.	D.M.
14	Dec 13, 2023	DPW 605 6 -8” – Added note regarding firelines to metered with backflow. Water used for fire fighting will not be charged.	D.M.
15	Dec 13, 2023	DPW 607-removed the 100m distance	D.M.
16	Dec 13, 2023	DPW 714-changed note #8 to reflect the Town standard DPW 706 for sign installs	D.M.
17	Jan 31 2025	Revised design spec (Section 6.5.6.)-changed 300mm diameter to 400mm diameter shall be installed in a valve chamber with extension stems and valve box on edge of the chamber.	D.M.
18	Jan 31 2025	Revised design spec (Section 6.12.8)-changed 100 meters to 60 meters in length shall be required o install a meter/pit chamber.	D.M.
19	Jan 31 2025	Revised TABLE OF CONTENTS-changed numbering from DPW 706 to DPW 717. (DPW 706 to DPW 707, DPW 707 to DPW 708, DPW 708 to DPW 710, DPW 709 to DPW 711, DPW 710 to DPW 712, DPW 711 to DPW 713, DPW 712 to DPW 714, DPW 713 to DPW 715, DPW 714 to DPW 716, DPW 715 to DPW 717)	D.M.
20	Jan 31 2025	Revised Index Series 700-changed numbering from DPW 706 to DPW 717.	D.M.
21	Jan 31 2025	Added new Streetlight Standard DPW 706 & 706A – Lighting Assembly Decorative (Type 3)	D.M.
22	Jan 31 2025	Added NEW Tree Protection Standard DPW 709	D.M.
23	Jan 31 2025	Revised DPW 708 – added note #4, #5 and #6. Revised note #1. Added note on drawing regarding burlap and wire.	D.M.
24	Jan 31 2025	Revised DPW 600 (Hydrant) – Added AVK Series & Clow/Brigadier M67B and removed Mcavity.	D.M.
25	Feb 20 2025	Revised DPW 714 – added more details for the Standard Header Detail and updated the Sign Panel Detail	D.M.
26	March 5 2025	Design Spec (Section 7.5)- changed title, added (a-e) and Responsibility of Topsoil Quality	D.M.



Document Revision Table

No.	Revision Date (M/D/Y)	Change	By
27	Sept 2025	Dead End Barricaded Updated	D.M.
28	Dec 2025	Sanitary Backwater Valve Installation Detail Residential Lateral – DPW 508	D.M.